

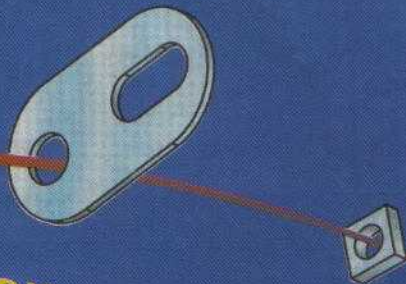

HOW TO EFFICIENTLY BUILD YOUR MODELS  
POUR BIEN RÉUSSIR TES MODÈLES

DAMIT DEINE MODELLE GUT GELINGEN  
PER REALIZZARE I TUOI MODELLI CON SUCCESSO  
FÖR ATT BYGGA LYCKADE MODELLER



JOTTA PIENOISMALLISI ONNISTUISIVAT  
SÅDAN LYKKES MODELLERNE FOR DIG  
PARA UNA BUENA CONSTRUCCIÓN DE TUS MODELOS

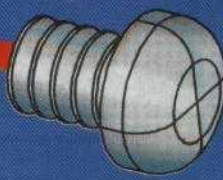

OM JE MODELLEN GOED TE KUNNEN MAKEN  
CONSEGUE OS TEUS MODELOS CON ÊXITO  
Για να φτιάξετε σωστά τα μοντέλα  
上手にモデルを作り上げるために



(GB) HOW TO USE YOUR TOOLS : SPANNER AND ALLEN KEY.  
 (I) UTILIZZAZIONE DEGLI ATTREZZI.  
 (DK) BRUG AF MONTERINGSNØGLERNE.  
 (P) UTILIZAÇÃO DAS CHAVES DE MONTAGEM.

(F) UTILISATION DES CLÉS DE MONTAGE.  
 (S) ANVÄNDNING AV MONTERINGSNYCKLARN.  
 (E) UTILIZACIÓN DE LAS LLAVES DE MONTAJE.  
 (GR) Χρήση των κλειδιών συναρμολόγησης.

(D) BENUTZUNG DER MONTAGESCHLÜSSEL.  
 (SF) ASENNUSAVAITEN KÄYTTÖ.  
 (NL) GEBRUIK VAN DE SLEUTELS VOOR DE MONTAGE.  
 (JP) 組み立てようレンチの使用

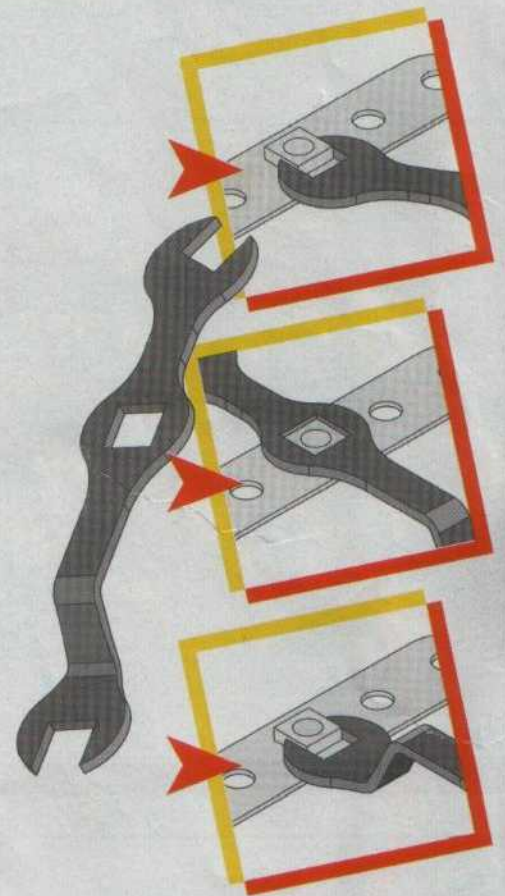
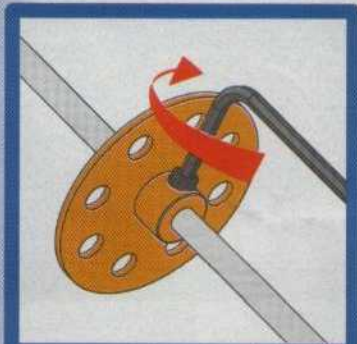
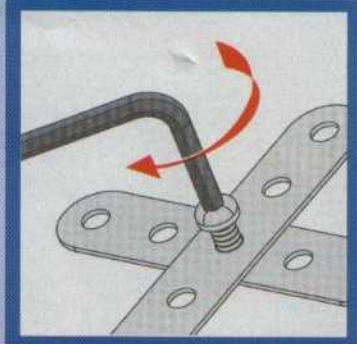
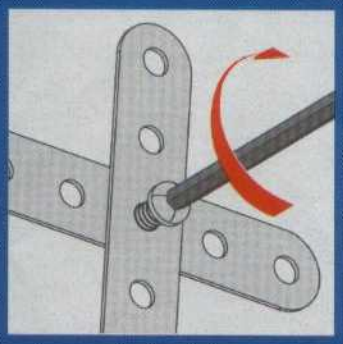

(GB) TIGHTENING NUTS AND BOLTS.  
 (S) FASTSPÄNNINGSFASER.  
 (NL) AANTREKFASES.

(F) PHASES DE SERRAGE.  
 (SF) KIRISTYSVAIHEET.  
 (P) FASES DE APERTO.

(D) ANZIEHSTUFEN.  
 (DK) TILSPÆNDINGSFASER.  
 (GR) φάσεις σύσφιξης.

(I) COME SERRARE INSIEME I VARI PEZZI.  
 (E) FASES DE APRIETE.  
 (JP) 締付け段階

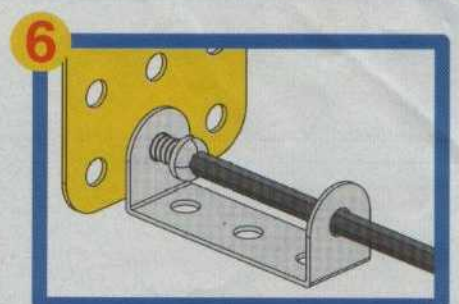
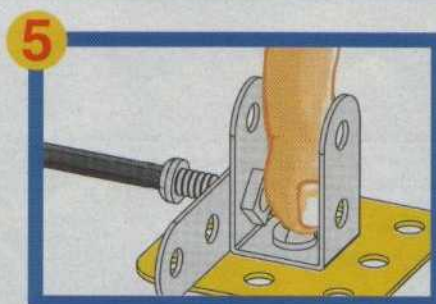
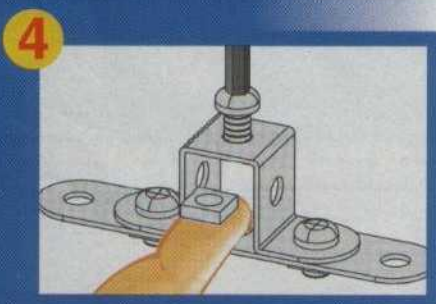
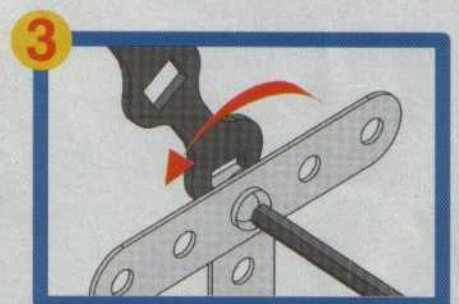
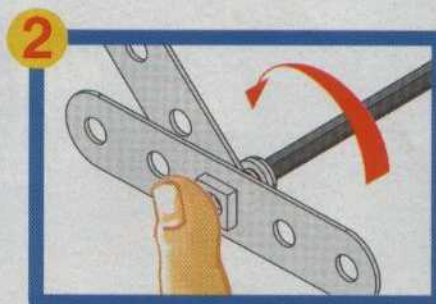
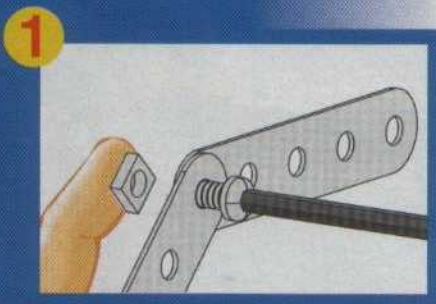



- (GB) TO MAKE BUILDING EASY : STEP BY STEP ASSEMBLY AND SELECTION OF REQUIRED PARTS.
- (D) STUFENWEISE MONTAGE UNTER VORBEREITUNG DER TEILE.
- (S) STEGVIS MONTERING MED FÖRBEREDELSE AV DELARNA.
- (DK) TRINVIS MONTERING MED FORBEREDELSE AF DELENE.
- (NL) STAP VOOR STAP MONTAGE DOOR DE ONDERDELEN VOOR TE BEREIDEN.
- (GR) Σταδιακή συναρμολόγηση με προετοιμασία των τεμαχίων.

- (F) MONTAGE ÉTAPE PAR ÉTAPE EN PRÉPARANT LES PIÈCES.
- (I) SEGUI TUTTI I PASSAGGI PER ASSEMBLARE I PEZZI.
- (SF) OSIEN VALMISTUS JA ASENNUS ASKEL ASKEELELTA.
- (E) MONTAJE ETAPA POR ETAPA, PREPARANDO LAS PIEZAS.
- (P) MONTAGEM ETAPA POR ETAPA AO PREPARAR AS PEÇAS.
- (JPN) パーツを用意しながら順を追って組み付け

1

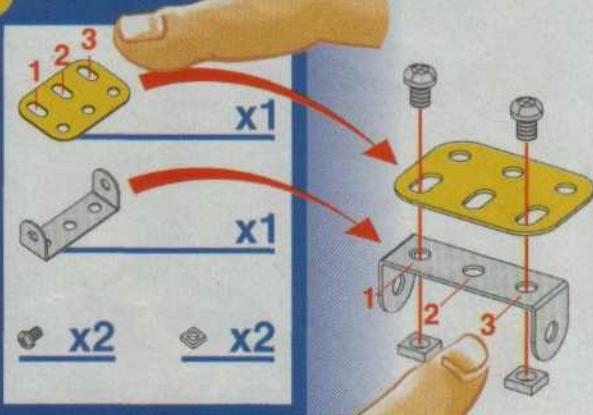

2 +1

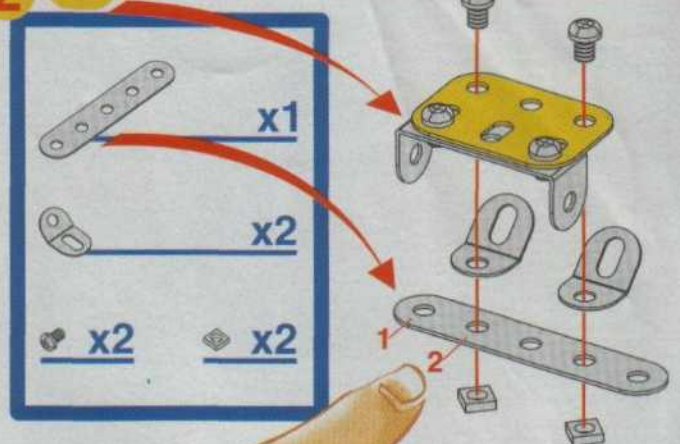

3 +2

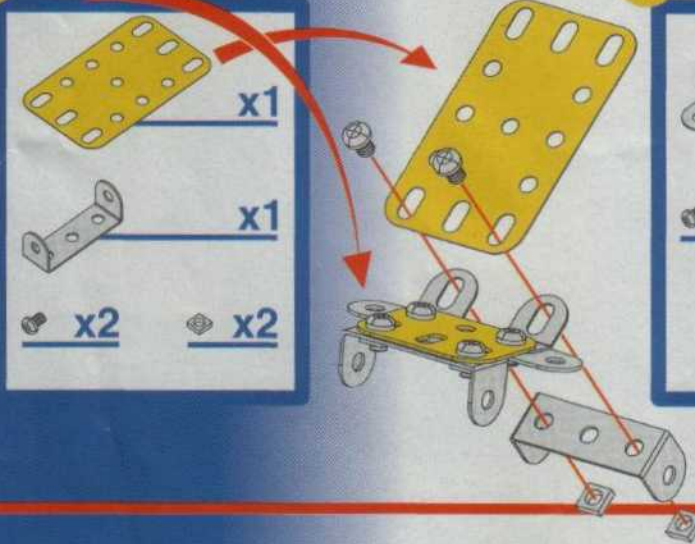

4 +3

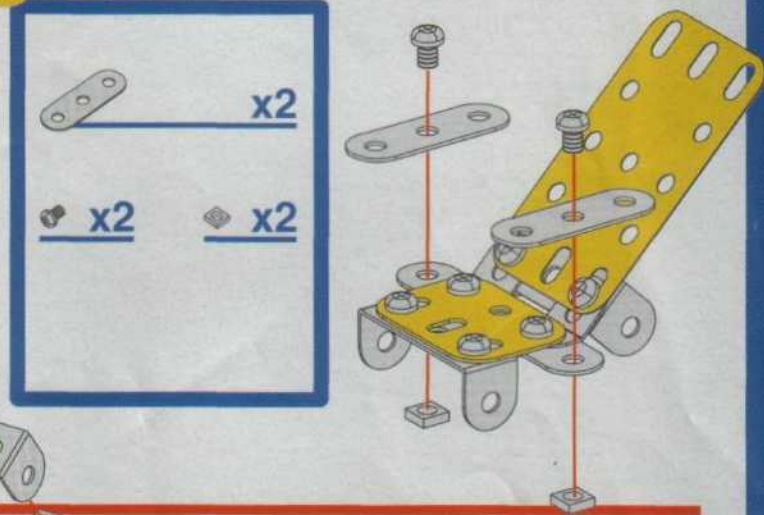

- (GB) ALIGN YOUR AXLES.
- (S) RIKTNING AV AXLARNA.
- (NL) UTLIJNING VAN DE ASSEN.

- (F) ALIGNEMENT DES AXES.
- (SF) AKSELEIDEN YHDENSUUNTAUS.
- (P) ALINHAMENTO DOS EIXOS.

- (D) AUSRICHTUNG DER ACHSEN.
- (DK) ANBRINGELSE AF AKSLERNE PÅ LINJE.
- (GR) Ευθυγράμμιση πείρων.

- (I) ALLINEAMENTO DEGLI ASSI.
- (E) ALINEACIÓN DE LOS EJES.
- (JPN) シャフトアライメント

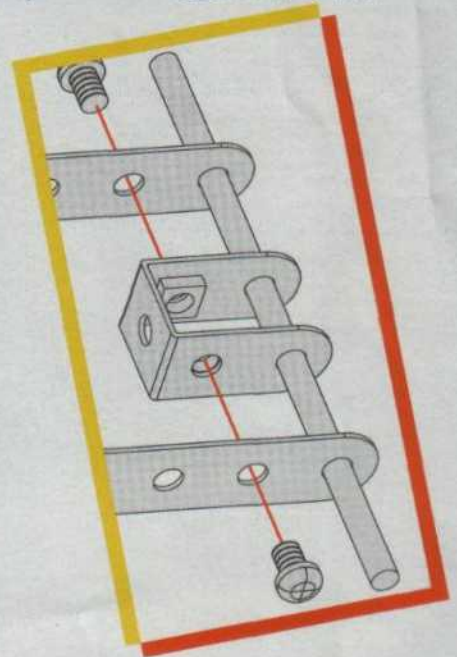
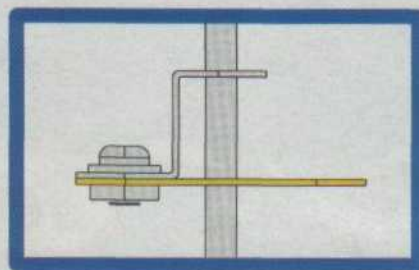
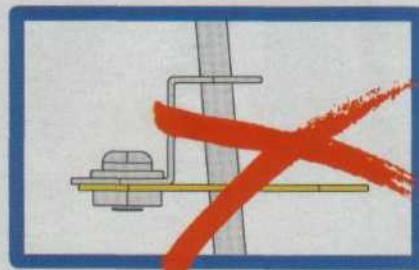
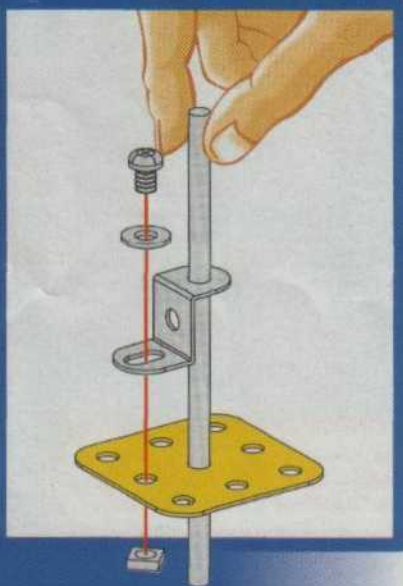



- (GB) BUILDING AXLE AND BEARING STANDS.
- (I) SUPPORTI DI ASSI O CUSCINETTI.
- (DK) AKSELHOLDERE ELLER AKSELLEJER.
- (P) SUPORTE DE EIXOS OU MANCAIS.

- (F) SUPPORTS D'AXES OU PALIERS.
- (S) AXELSTÖTTOR ELLER LAGER.
- (E) SOPORTE DE EJES O COJINETES.
- (GR) Στηρίγματα πειρών ή έδρανα.

- (D) ACHSEN- ODER LAGERSUPPORTS.
- (SF) AKSELEIDEN TAI LAAKEREIDEN TUET.
- (NL) STEUNEN VAN SCHARNIERPENNEN OF LAGERS.
- (JPN) シャフトブラケットまたは軸受け

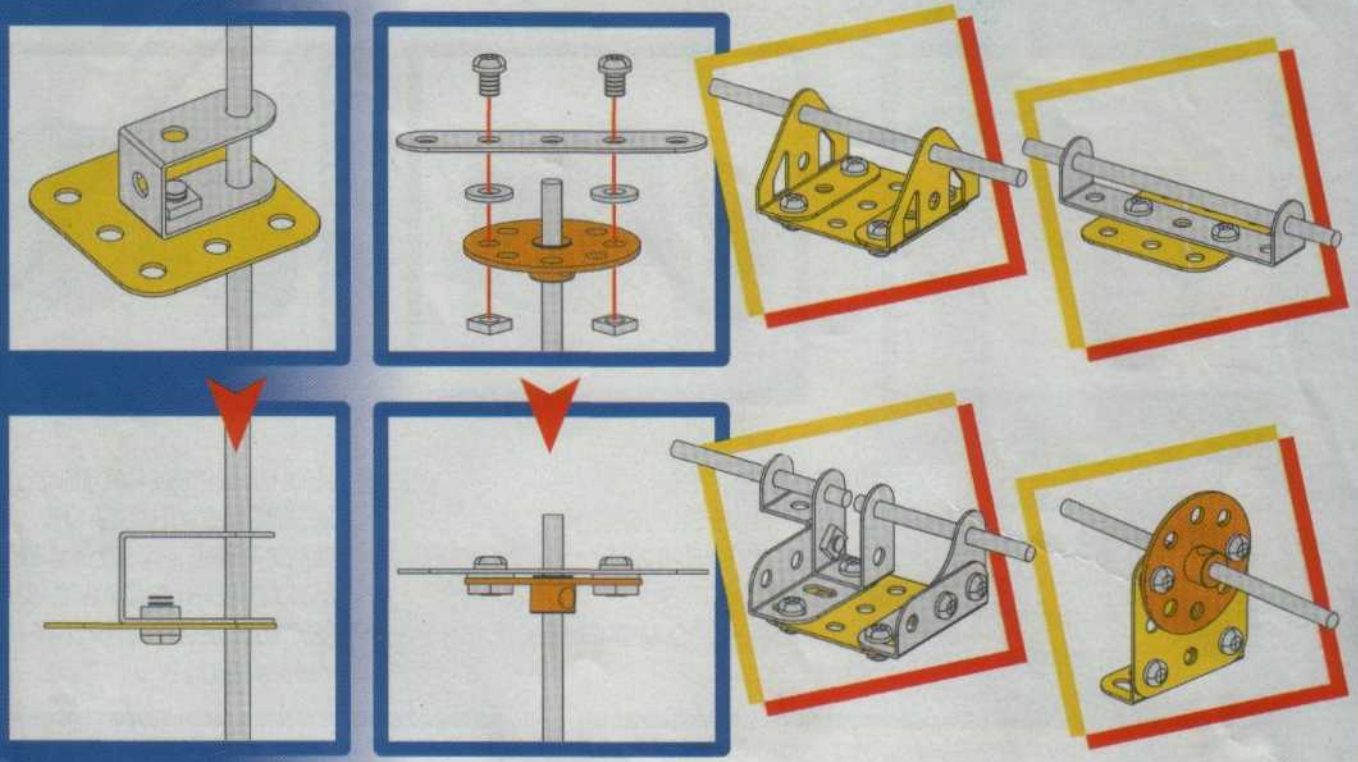

- (GB) HOW TO ASSEMBLE SHOCK ABSORBERS.
- (I) ASSEMBLAGGIO DEGLI AMMORTIZZATORI.
- (DK) MONTERING AF STØDDÆMPERNE.
- (P) MONTAGEM DOS AMORTECEDORES.

- (F) MONTAGE DES AMORTISSEURS.
- (S) MONTERING AV STÖTDÄMPARNA.
- (E) MONTAJE DE LOS AMORTIGUADORES.
- (GR) Τοποθέτηση αμορτισέρ.

- (D) MONTAGE DER DÄMPFER.
- (SF) ISKUNVAIMENTIMEN ASENNUS.
- (NL) MONTAGE VAN DE SCHOKDEMPERS.
- (JPN) ダンパー組み立て

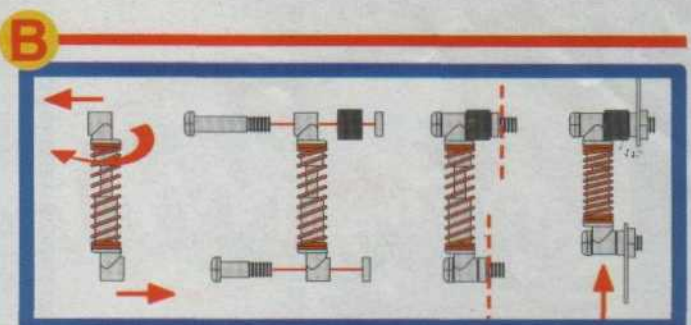
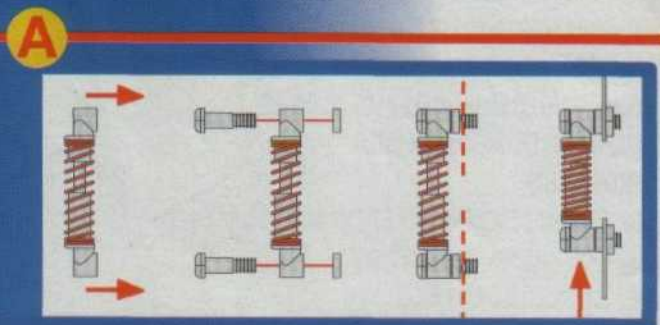
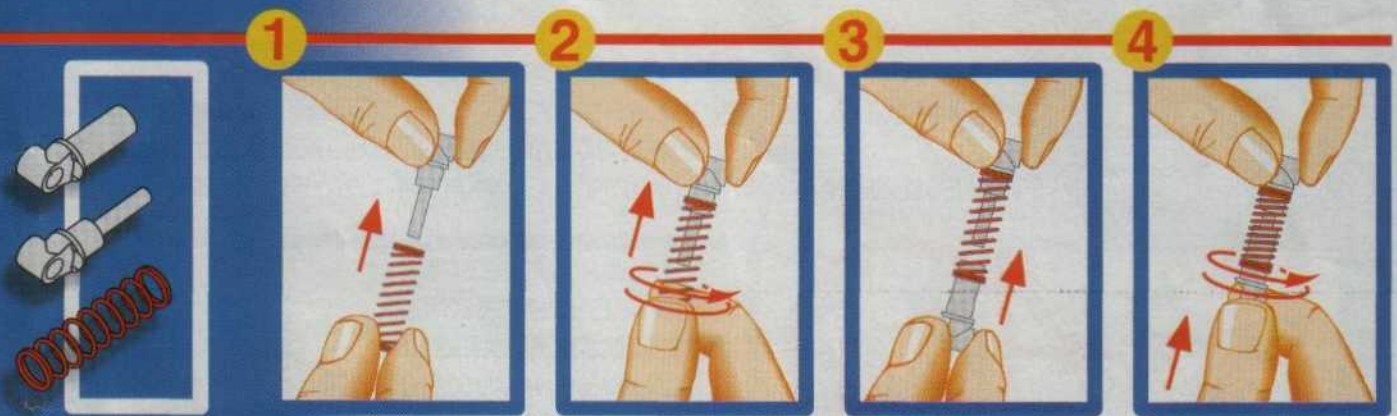



- (GB) HOW TO USE GEARS TO REDUCE (ROTATION) SPEED.
- (D) GESCHWINDIGKEITSMINDERUNG ÜBER ZAHNGETRIEBE.
- (S) HASTIGHETSÄNKNING MEDELS KUGGHJUL.
- (DK) HASTIGHEDSFORMINDSKELSE GENNEM TANDHJULSFORBINDELSER.
- (NL) SNELHEIDVERLAGING DOOR TANDWIELSTELSLS.
- (GR) Μείωση ταχύτητας με γρανάζια.

- (F) RÉDUCTION DE VITESSE PAR ENGRENAGES.
- (I) RIDUZIONE DI VELOCITÀ CON INGRANAGGI.
- (SF) VAUHDIN ALENNUS HAMMASPYÖRÄSTÖLLÄ.
- (E) REDUCCIÓN DE VELOCIDAD POR ENGRANAJES.
- (P) REDUÇÃO DE VELOCIDADE POR ENGRENAGENS.
- (JPN) ギアによる減速

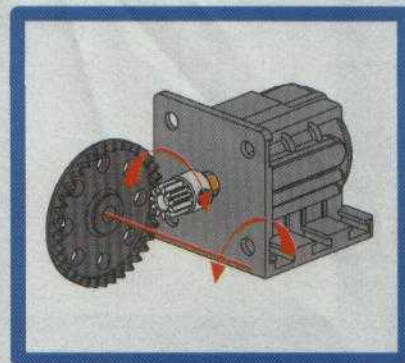
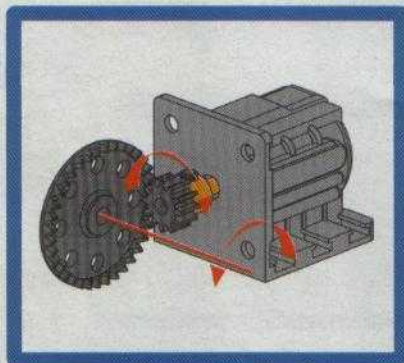
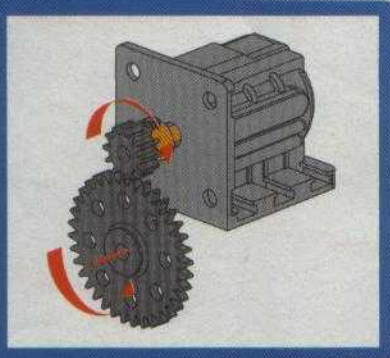

- (GB) HOW TO USE DRIVE BELTS TO REDUCE (ROTATION) SPEED.
- (D) GESCHWINDIGKEITSRREDUZIERUNG ÜBER TREIBRIEMEN UND GEMISCHT.
- (S) HASTIGHETSÄNKNING MEDELS REMMAR OCH BLANDAD DRIFT.
- (DK) KOMBINERET HASTIGHEDSFORMINDSKELSE GENNEM REMME.
- (NL) SNELHEIDVERLAGING DOOR VERSCHILLENDE SOORTEN AANDRIJFRIEMEN.
- (GR) Μείωση ταχύτητας με ιμάντες και μεικτή.

- (F) RÉDUCTION DE VITESSE PAR COURROIES ET MIXTE.
- (I) RIDUZIONE DI VELOCITÀ CON CINGHIE.
- (SF) VAUHDIN ALENNUS HIHNASTOLLA JA KOMBINOIDEN.
- (E) REDUCCIÓN DE VELOCIDAD POR CORREAS Y MIXTO.
- (P) REDUÇÃO DE VELOCIDADE POR CORREIAS E MISTO.
- (JPN) ベルトによる減速およびミックス式

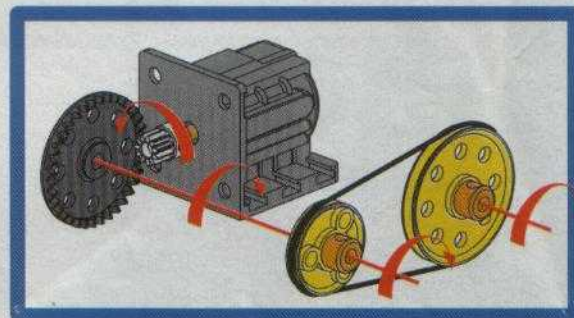
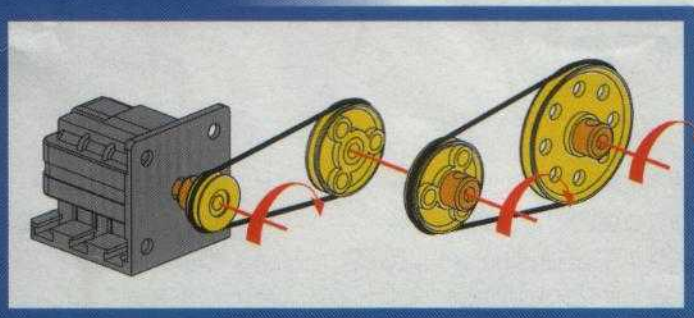

- (GB) ADJUSTING YOUR GEARWHEELS.
- (I) AGGIUSTAMENTI DEL PIGNONE DI AVANZAMENTO.
- (DK) JUSTERING AF DREV.
- (P) REGULAMENTO DAS ENGRANAGENS DE ARRASTO.
- (F) RÉGLAGES DES PIGNONS D'ENTRAÎNEMENT.
- (S) INSTÄLLNINGAR AV DRIVHJULEN.
- (E) REGLAJE DE LOS PIÑONES DE ARRASTRE.
- (GR) Ρυθμίσεις των γραναζιών μετάδοσης κινήσεως.
- (D) EINSTELLUNG DER ANTRIEBS-ZAHNRÄDER.
- (SF) VETOPYÖRIEN SÄÄDÖT.
- (NL) AFSTELLING VAN DE AANDRIJFTANDWIJLEN.
- (JPN) ドライブピニオン調整

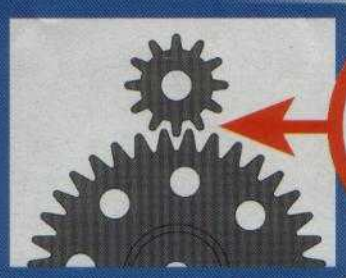
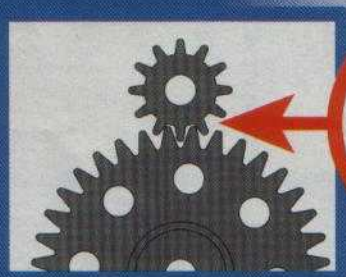

- (GB) OILING YOUR GEARS AND BEARINGS.
- (F) HUIER LES ENGRENAGES ET PALIERS.
- (D) DIE ZAHNGETRIEBE UND LAGER ÖLEN.
- (I) LUBRIFICARE GLI INGRANAGGI E I CUSCINETTI.
- (S) SMÖRJNING AV KUGGHJUL OCH LAGER.
- (SF) LAAKERIEN JA HAMMASPYÖRIEN VOITELU.
- (DK) TANDHJULSFORBINDELSER OG AKSELLEJER SMØRES.
- (E) LUBRIFICAR LOS ENGRANAJES Y LOS COJINETES.
- (NL) SMEREN VAN DE TANDWIELSTELSLS EN DE LAGERS.
- (P) LUBRIFICAR AS ENGRANAGENS E OS MANCAIS.
- (GR) Λαδώστε τα γρανάζια και τα έδρανα.
- (JPN) ギアおよび軸受け部を注油すること

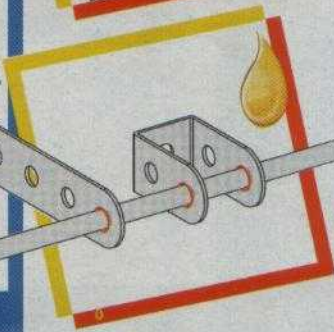

**(GB):** Many of the models and component parts are unique and original designs which are the property of MECCANO S.A. They are protected by national legislation as industrial designs, trademarks and/or copyrights throughout many countries. For detailed information, please contact MECCANO S.A. MECCANO takes no responsibility where instructions have not been followed, where pieces have been put to uses other than those in the instructions, or have been modified for another use.

**(F):** De nombreux modèles et pièces sont des créations originales, propriétés de MECCANO S.A. et sont protégés par les législations nationales sur les dessins et modèles, marques et/ou droits d'auteurs. Pour toute information, merci de contacter : MECCANO S.A.

MECCANO se dégage de toutes responsabilités en cas de non-respect des indications de montage, utilisation des pièces pour un autre usage que celui indiqué dans les notices et/ou modification des pièces.

**(D):** Zahlreiche Modelle und Teile sind Erfindungen und Eigentum der Firma MECCANO S.A. Sie sind durch Inland-Gesetze über Zeichnungen und Modelle sowie Warenzeichen und/oder Urheberrechte geschützt. Für zusätzliche Auskünfte wenden Sie sich bitte an MECCANO S.A.

MECCANO kann keine Haftung übernehmen, wenn die Anleitungen nicht befolgt oder wenn Teile anders als in den Anleitungen vorgesehen eingesetzt oder abgeändert werden.

**(I):** Numerosi modelli e pezzi sono creazioni originali, proprietà della MECCANO S.A. e sono protetti dalle legislazioni nazionali sui disegni e modelli, marchi e/o diritti d'autore. Per qualsiasi informazione, vogliono prendere contatto con : MECCANO S.A.

MECCANO non si assume alcuna responsabilità qualora le istruzioni non vengono seguite, le parti componenti vengono impiegate in modo diverso da quanto illustrato o siano state modificate per usi differenti dal montaggio dei modelli MECCANO.

**(S):** Många modeller och delar bildar en unik och original formgivning, vilken är MECCANO S.A. egendom. Dessa modeller och delar är skyddade genom lagstiftning såsom industriell formgivning, varumärke och/eller upphovsrätt i en flertal länder. För mer detaljerad information, var vänlig och kontakta MECCANO S.A.

MECCANO kan ej ta ansvar för något då instruktionerna ej har följts, då delar har använts till annat än vad instruktionerna aviserat eller att delarna har blivit modifierade till annan användning.

**(SP):** Vore multe modeler og dele er originale fremstillinger og ejes af MECCANO S.A. Tegninger, modeller, fabrikmærker og ophavret er lovbekyttede i hvert land. Yderligere oplysninger kan fås hos : MECCANO S.A.

MECCANO ei ota vastuuta, jos osia on käytetty muuhun kuin ohjeiden suosittelemaan käyttötarkoitukseen tai jos osia on itse muutettu.

**(DK):** Uset mallit je osat ovat MECCANO S.A.-n omisuutta olevia suunnitelmia. Uset mallit osat ovat lailla suojattua teollista tuotantoa, tavaramerkkejä jättä kopiaintioikeuksia useissa maissa. Tuotemerkki MECCANO on MECCANO S.A.-n omisuutta oleva rekisteröity tavaramerkki, jonka käyttö ilman lupaa on kielletty. Lisätietoja varten, ottakaa yhteyttä MECCANO S.A.

MECCANO fratager sig ald ansvar, hvis materialer bliver brugt til andet end det beregnede, når anvendelserne og forandringerne af delene ikke overholdes.

**(E):** Numerosos modelos y piezas son creaciones originales, propiedades de MECCANO S.A. y son protegidos por las legislaciones nacionales en lo que concierne a los dibujos y modelos, marcas y/o derechos de autor. Para cualquier información, sírvase ponerse en contacto con : MECCANO S.A.

MECCANO no se responsabilizará en aquellos casos en que no se hayan seguido las instrucciones, las piezas se hayan usado con distinto fin al indicado en las instrucciones, o bien se hayan modificado para otros usos.

**(NL):** Veel modellen en onderdelen zijn een uniek en origineel ontwerp, hetgeen eigendom van MECCANO S.A. is. Deze modellen genieten bescherming als industrieel ontwerp, handelsmerk en/of copyright in talrijke landen. Voor uitgebreide informatie, s.v.p. contact opnemen met MECCANO S.A.

MECCANO is niet verantwoordelijk voor het niet opvolgen van de instructies, voor verkeerd gebruik van de onderdelen of het gebruiken van onderdelen voor andere doeleinden.

**(P):** Numerosos modelos e peças são criações originais, propriedades de MECCANO S.A. e são protegidos pelas legislações nacionais segundo os desenhos, os modelos, as marcas e/ou os direitos autorais. Para quaisquer informações, quere contactar: MECCANO S.A.

MECCANO não assumirá nenhuma responsabilidade sempre que as instruções não tenham sido seguidas, as peças tenham sido utilizadas noutros fins que não os contidos nas nossas instruções, ou tenham sido modificadas para outras utilizações.

**(GR):** Πολλά μοντέλα και ανταλλακτικά είναι πρωτότυπα, ιδιοκτησία της MECCANO A.E. και προστατεύονται από τις εθνικές νομοθεσίες για τα μοντέλα, τις εμπορικές ή τα διπλώματα ευρεσιτεχνίας. Για κάθε πληροφορία παρακαλώ απευθυνθείτε στην MECCANO A.E.

Η MECCANO δεν φέρει καμία ευθύνη σε περίπτωση που δεν τηρηθούν οι οδηγίες συναρμολόγησης, σε περίπτωση που το συναρμολογούμενο κομμάτι χρησιμοποιούν για άλλη χρήση από εκείνη που αναφέρεται στις οδηγίες, χρήσης και/ή σε περίπτωση που τροποποιήσουν.

**(FR):** モデルならびに部品は、その多くがメカノ社所有のオリジナルデザインで、意匠・商標および/または著作権に関する国内法によって保護されています。詳細については、メカノ社 (MECCANO S.A.) までお問い合わせ願います。

指定の組立方法に従わない場合や説明書にない用途に部品を用いた場合、また部品を改造した場合、メカノはその責任を一切負いません。

Made in France by :  
Hecho en Francia :  
Fabriqué en France par :



Avenue de Saint-Exupéry - 62100 CALAIS - FRANCE