

MECCANO Coal Tippler

(MODEL No. 10.3)

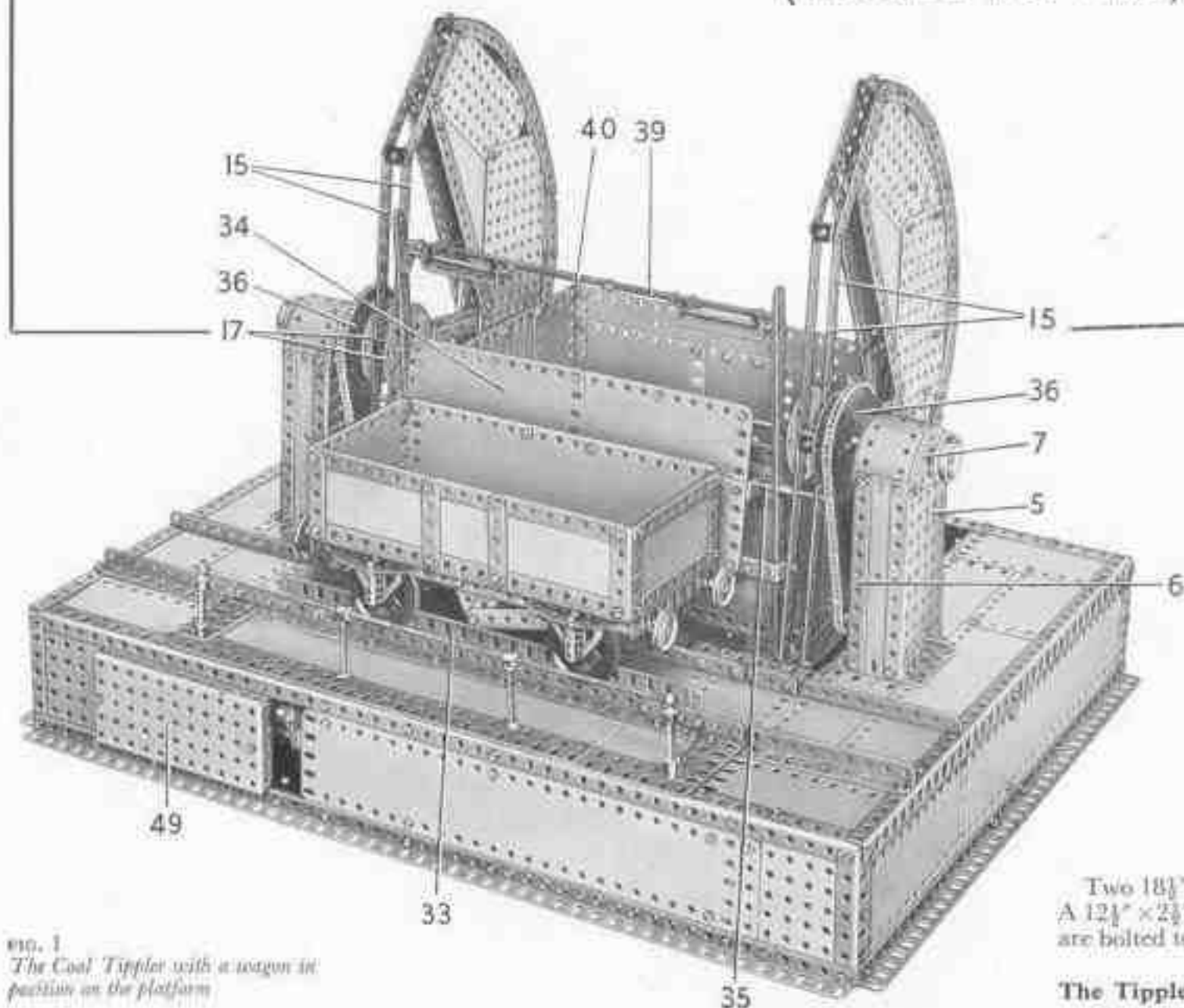

FIG. 1
The Coal Tippler with a wagon in position on the platform

Coal wagon tipplers are ingenious appliances that permit railway wagons to be emptied of their loads completely and quickly. Such discharge in bulk is required at power stations and many other industrial installations such as gas and steel works. Tipplers of various types are used also in connection with coal and ash handling plants at steam locomotive depots.

The operation of the model Tippler described in this leaflet is as follows. First the wagon is run on to the rails of the Tippler platform. Then the Motor is switched on and the

SPECIAL FEATURES

The Coal Tippler is driven by a Meccano E15R type Electric Motor. While tipping is in process the wagon is held firmly on the tipping platform by a heavy pivoted beam that comes into action automatically as soon as tipping commences.

platform swings upward. As it does so a pivoted locking beam comes into action and presses on the top of the wagon to hold it firmly on the rails. At the peak of its travel the contents of the wagon are discharged into a hopper, and the Motor is then reversed to lower the platform and wagon to ground level again, so that the empty wagon can be drawn off and replaced by another loaded one.

Construction of the Model: The Base (Fig. 2)

Each side of the base consists of two $1\frac{1}{2}$ " Angle Girders joined at their ends by $3\frac{1}{2}$ " Angle Girders, and connected at the centre by a $3\frac{1}{2}$ " x $2\frac{1}{2}$ " Flanged Plate (1) (Fig. 2). The sides are filled in by $12\frac{1}{2}$ " x $2\frac{1}{2}$ " Strip Plates. The sides are connected at the front and the back by $2\frac{1}{2}$ " Angle Girders, with the corners strengthened by $3\frac{1}{2}$ " x $2\frac{1}{2}$ " Flanged Plates (2). The $2\frac{1}{2}$ " Angle Girders are braced at the centre by $5\frac{1}{2}$ " x $3\frac{1}{2}$ " Flat Plates, and at the front two 3 " x $1\frac{1}{2}$ " Flat Plates (3) are bolted between the Girders. The front and the back are completed by $12\frac{1}{2}$ " x $2\frac{1}{2}$ " Strip Plates, as shown in Figs. 1 and 2.

Two $1\frac{1}{2}$ " Angle Girders (4) are bolted across the top of the base at each end (Fig. 2). A $12\frac{1}{2}$ " x $2\frac{1}{2}$ " Strip Plate, three $4\frac{1}{2}$ " x $2\frac{1}{2}$ " Flexible Plates and two $5\frac{1}{2}$ " x $2\frac{1}{2}$ " Flexible Plates, are bolted to these Girders at each end to fill in the top.

The Tippler Supporting Columns (Figs. 1, 2, 3, 5 and 7)

The outer face of each column is a $5\frac{1}{2}$ " x $2\frac{1}{2}$ " Flanged Plate (5) fixed to a $2\frac{1}{2}$ " Angle Girder bolted to one of the Girders (4). The inner face is formed by two $5\frac{1}{2}$ " Angle Girders (6) supported by a $2\frac{1}{2}$ " Angle Girder fixed to the second of the Girders (4). The Flanged Plate (5) and the Girders (6) are extended upward by Semi-Circular Plates (7) (Fig. 5), and the sides and top of the column are filled in by $5\frac{1}{2}$ " x $1\frac{1}{2}$ " Flexible Plates. A $7\frac{1}{2}$ " Strip (8) (Fig. 7) is bolted to the inner face of the column, and a $2\frac{1}{2}$ " Strip (9) is fixed to the Flanged Plate (5) and to a $1\frac{1}{2}$ " Angle Girder attached to one of the Girders (4). The lower ends of Strips (8) and (9) are connected by a $1\frac{1}{2}$ " x $\frac{1}{2}$ " Double Angle Strip.

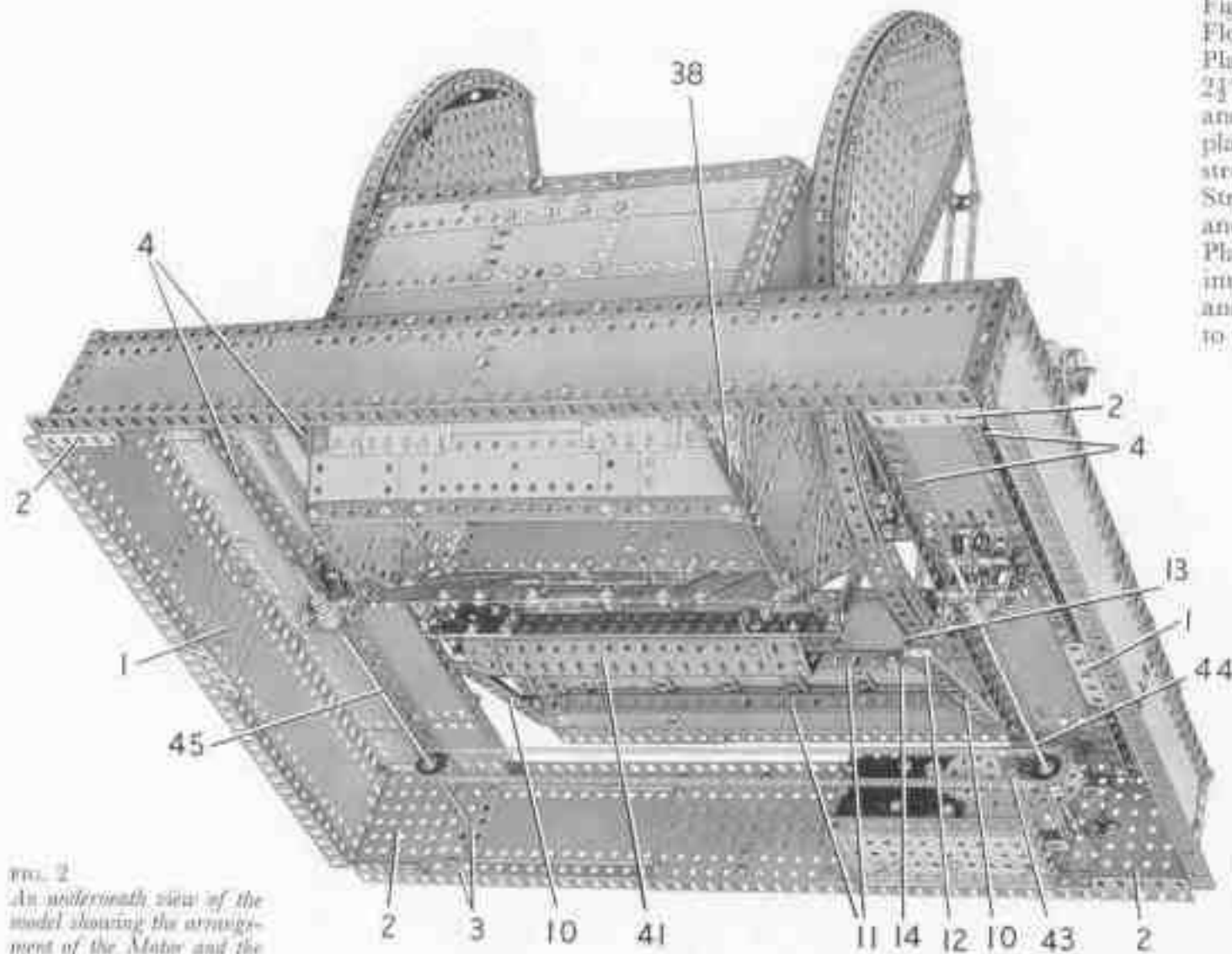

FIG. 2
An isometric view of the model showing the arrangement of the Motor and the gearing.

The Tippler Platform and Counter-Balance Weights (Figs. 1, 2, 3, and 5)

The frame that supports the platform (Fig. 3) consists of two $5\frac{1}{2}$ " Angle Girders (10) connected by $1" \times \frac{1}{2}"$ Angle Brackets to two built-up girders (11). Each of these girders is formed by two $12\frac{1}{2}"$ Angle Girders overlapped 23 holes. A Bell Crank (12), a $1"$ Corner Bracket (13), and a $1" \times 1"$ Angle Bracket (14) are fixed to the inner end of each of the Girders (10) by a $\frac{3}{8}"$ Bolt. This Bolt passes through the boss of the Bell Crank, and the Corner Bracket is spaced from the Bell Crank by a Collar. The Angle Brackets (14) are bolted to the inner one of the girders (11).

The frame that supports each counter-balance consists of two $12\frac{1}{2}"$ Strips (15) (Fig. 5) bolted to the Bell Crank (12) and to Corner Bracket (13). These Strips are connected at a point 14 holes from their lower ends, by a Double Bracket, and at their upper ends by another Double Bracket. The bolts that fix the centre Double Bracket secure also two $5\frac{1}{2}"$ Strips (16), to each of which is fastened a Face Plate (17) (Fig. 1). The Strips (16) are connected by a Double Bent Strip.

Two $4\frac{1}{2}"$ Strips (18) are fixed to the top ends of the Strips (15), and two $5\frac{1}{2}"$ Curved Strips (19) are bolted to their lower ends. The outer edges of the counter-balance are formed by two further $5\frac{1}{2}"$ Curved Strips and two $4"$ Stepped Curved Strips, as shown in

Fig. 5. The outer face of each counter-balance is filled in by a $2\frac{1}{2}" \times 2\frac{1}{2}"$ Triangular Flexible Plate (21), a $4\frac{1}{2}" \times 2\frac{1}{2}"$ Flat Plate (22), a $3\frac{1}{2}" \times 1\frac{1}{2}"$ Triangular Flexible Plate, a $5\frac{1}{2}" \times 3\frac{1}{2}"$ Flat Plate, two $2\frac{1}{2}" \times 1\frac{1}{2}"$ Triangular Flexible Plates (23), a $2\frac{1}{2}" \times 1\frac{1}{2}"$ Flexible Plate (24), a $5\frac{1}{2}" \times 2\frac{1}{2}"$ Flat Plate (25), a $5\frac{1}{2}" \times 2\frac{1}{2}"$ Flexible Plate and a $3\frac{1}{2}" \times 2\frac{1}{2}"$ Triangular Flexible Plate (27). Three $12\frac{1}{2}"$ Angle Girders placed together are bolted on the inside of these Plates to add to the weight of the structure, and the inner edges of the counter-balance are finished by $5\frac{1}{2}"$ and $7\frac{1}{2}"$ Strips as shown. The inside face of each counter-balance is formed by a $5\frac{1}{2}" \times 2\frac{1}{2}"$ and a $5\frac{1}{2}" \times 3\frac{1}{2}"$ Flat Plate, a $5\frac{1}{2}" \times 2\frac{1}{2}"$ Flexible Plate (28), a $2\frac{1}{2}" \times 1\frac{1}{2}"$ Flexible Plate (29), a $4\frac{1}{2}" \times 2\frac{1}{2}"$ Flexible Plate (30) and a $4\frac{1}{2}" \times 2\frac{1}{2}"$ Flat Plate (31). The inner and outer faces of the counter-balance are connected by Double Brackets, and two curved $12\frac{1}{2}"$ Strips are fixed to the outer edges by Angle Brackets.

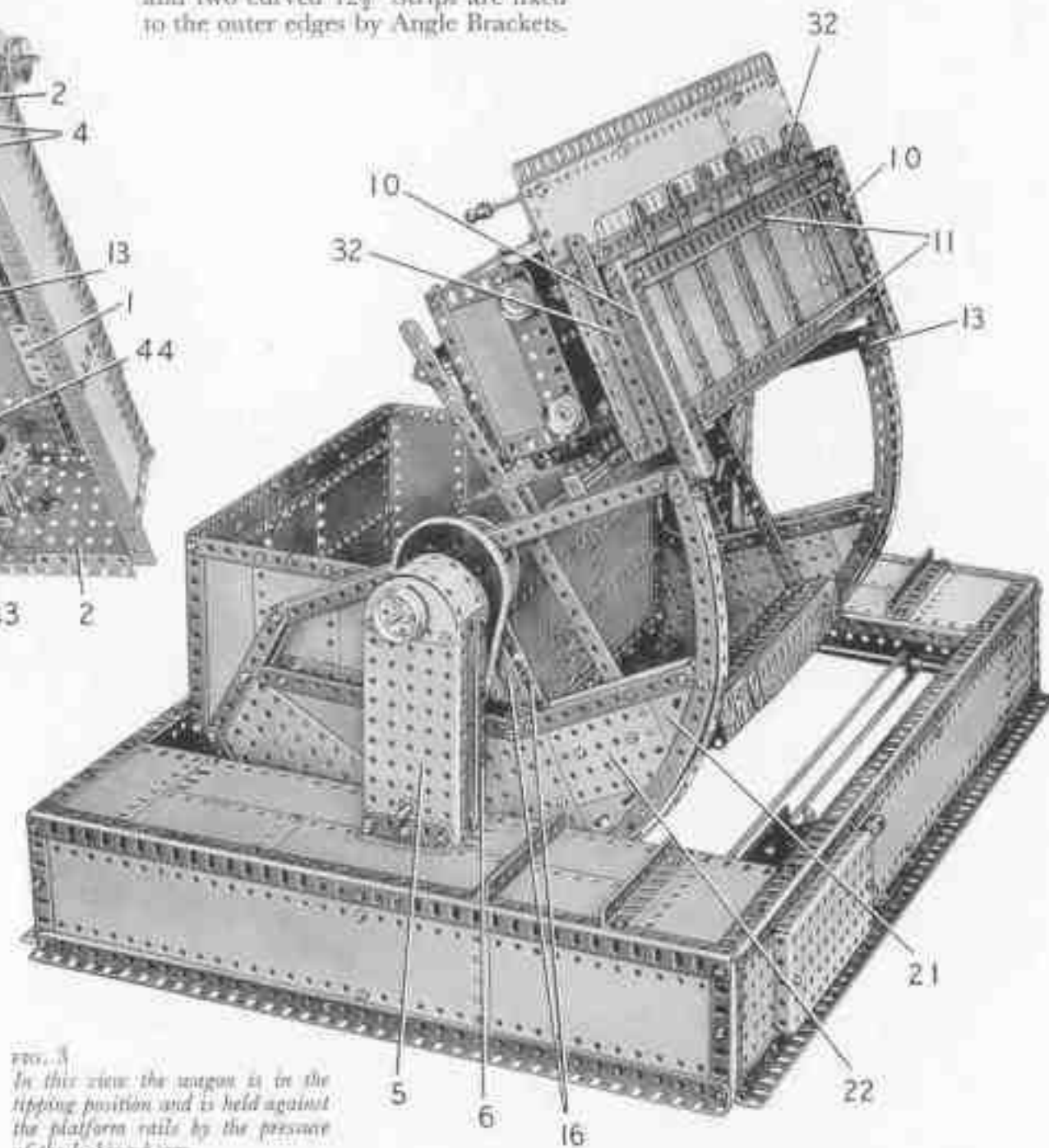

FIG. 3
In this view the wagon is in the tipping position and is held against the platform rails by the presence of the locking beam.

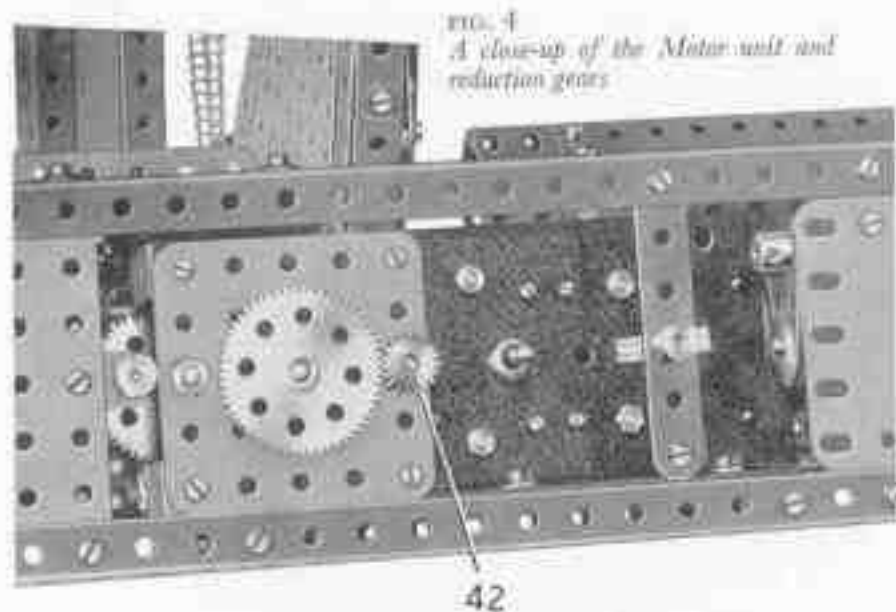

FIG. 4
A close-up of the Motor unit and
reduction gears

A $12\frac{1}{2}$ " Angle Girder (37) is bolted along one side of the hopper and is fixed to the back of the base. Two 3" Strips (38) are connected to the back of the base by $1" \times \frac{1}{2}"$ Angle Brackets.

The Wagon Locking Beam (Figs. 1 and 2)

As the tippler operates the wagon is held against the rails on the platform by the swinging beam (39) (Fig. 1) which bears against the top of the wagon. The side-members of this beam are each formed by two $12\frac{1}{2}"$ Strips placed face to face and pivoted 12 holes from their top ends on the rod (35). The upper ends of these Strips are connected by a built-up strip (40), bolted to $1" \times 1"$ Angle Brackets. The strip (40) consists of a $5\frac{1}{2}"$ Strip at each end overlapping a centre $5\frac{1}{2}"$ Strip by five holes. The end $5\frac{1}{2}"$ Strips have $2\frac{1}{2}"$ Strips bolted to them for strengthening purposes. A $2\frac{1}{2}" \times \frac{1}{2}"$ Double Angle Strip at each end of the strip (40) is pivoted on a $3\frac{1}{2}"$ Rod held by Spring Clips in two Angle Brackets bolted to the strip.

A weighted box-like structure (41) is bolted to two $2\frac{1}{2}" \times \frac{1}{2}"$ Double Angle Strips fixed to the lower ends of the $12\frac{1}{2}"$ Strips. It is made from four

The front section of the tippler platform consists of a $12\frac{1}{2}" \times 2\frac{1}{2}"$ Strip Plate and a $4\frac{1}{2}" \times 2\frac{1}{2}"$ Flexible Plate, overlapped three holes and edged by a $12\frac{1}{2}"$ and a $5\frac{1}{2}"$ Flat Girder. The platform is completed by five $5\frac{1}{2}" \times 2\frac{1}{2}"$ Flexible Plates and two $4\frac{1}{2}" \times 2\frac{1}{2}"$ Flexible Plates (Fig. 5). These Plates are strengthened underneath by two built-up strips, placed one along the rear edge of the platform and one below the join between the Strip Plate and the Flexible Plates. Each built-up strip is made from two $9\frac{1}{2}"$ Strips overlapped seven holes. The joins between the $5\frac{1}{2}" \times 2\frac{1}{2}"$ Flexible Plates are strengthened by $5\frac{1}{2}"$ Strips. Two $5\frac{1}{2}"$ Angle Girders (32) (Fig. 3), are bolted underneath the platform and a Fishplate lock-nutted to each of these Girders is bolted to one of the Girders (10).

Each platform rail is formed by a $12\frac{1}{2}"$ Angle Girder and two $1\frac{1}{2}"$ Angle Girders connected by 3" Strips. A check rail (35) consists of a $12\frac{1}{2}"$ Flat Girder spaced from the running rail by two Washers on each of its securing bolts.

A backplate (34) (Fig. 1) above the platform is formed by four $5\frac{1}{2}" \times 2\frac{1}{2}"$ Flexible Plates bolted together, with the joins and edges strengthened by two $4\frac{1}{2}"$ Strips and six $5\frac{1}{2}"$ Strips. This backplate is connected to two of the Strips (15) by $1" \times 1"$ Angle Brackets, and two further $1" \times 1"$ Angle Brackets are passed over a made-up rod (35). This Rod consists of a 1" Rod and two $6\frac{1}{2}"$ Rods connected by Couplings, and it is held in the Strips (15) by two Collars, and two further Collars space the backplate from Strips (15). Two $7\frac{1}{2}"$ Angle Girders are attached to the centre of the backplate by Angle Brackets.

A 3" Sprocket (36) is attached by two $\frac{1}{2}"$ Bolts to the outer one of each pair of Face Plates (17). The platform and its counter-balances pivot on a made-up rod mounted in the Semi-Circular Plates (7). This rod consists of an 8" Rod and two $6\frac{1}{2}"$ Rods joined by Couplings, and it is held in position by two $1\frac{1}{4}"$ Flanged Wheels.

Assembly of the Hopper (Fig. 6)

The hopper is shown removed from the base in Fig. 6. It should be noted that the $3\frac{1}{2}" \times 2"$ Triangular Flexible Plates seen at one end in Fig. 6 are replaced at the other end by $2\frac{1}{2}" \times 1\frac{1}{2}"$ Triangular Flexible Plates. The top corners of the sloping sides of the hopper are strengthened by Corner Gussets.

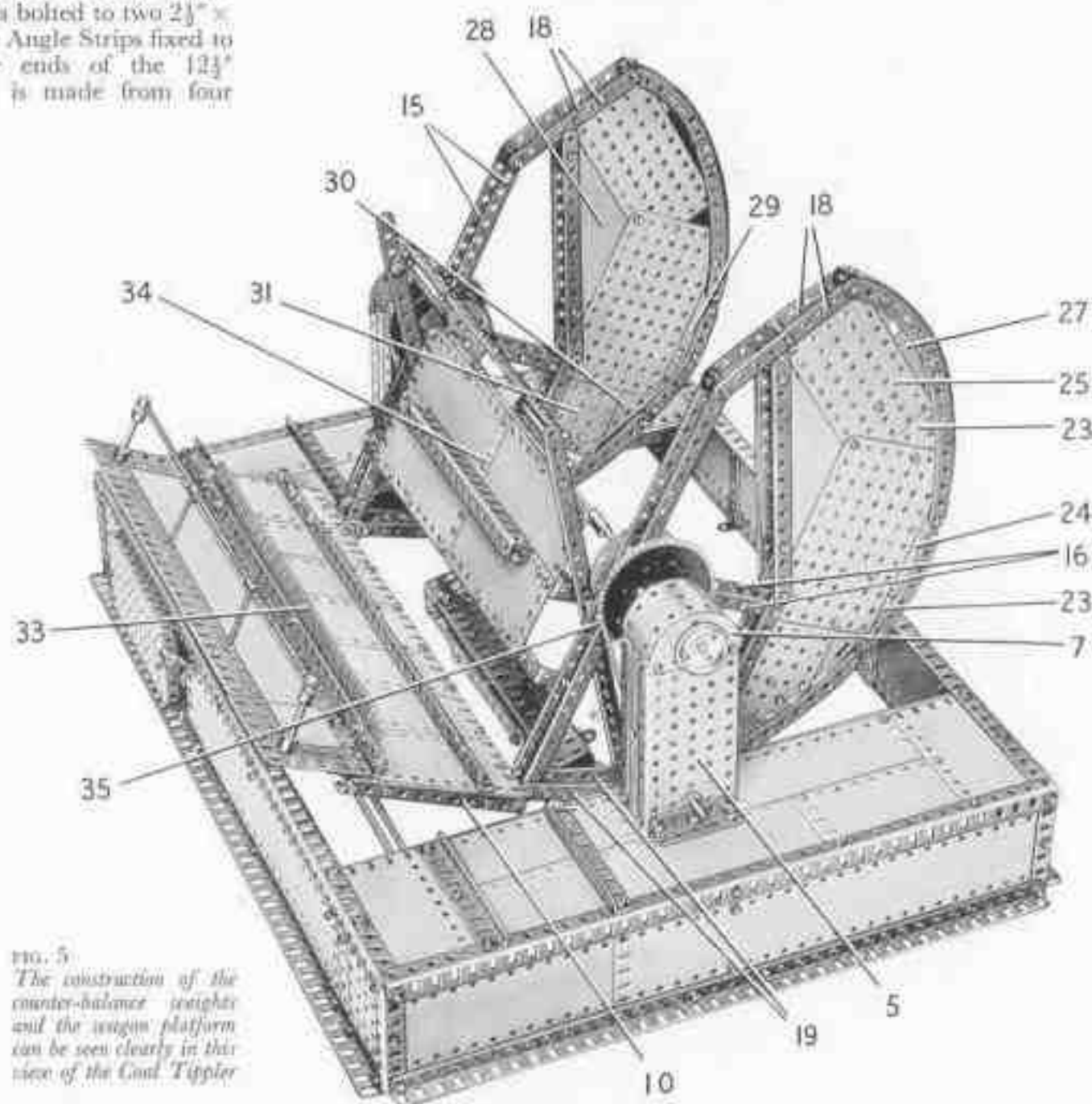

FIG. 5
The construction of the
counter-balance weights
and the wagon platform
can be seen clearly in this
view of the Coal Tippler

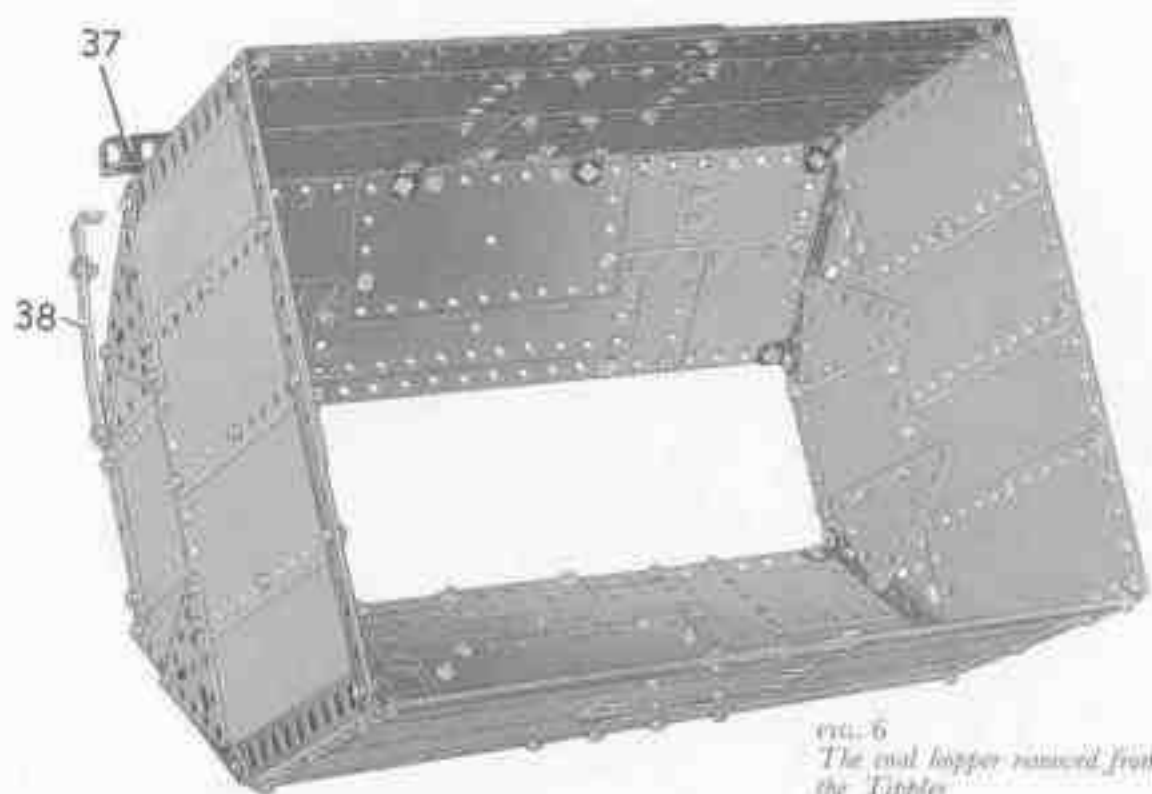

FIG. 6
The coal hopper removed from the Tippler

9½" Flat Girders connected together by two 9½" Angle Girders and two 7¼" Angle Girders, and is weighted by bolting 7¼", 5½" and 4½" Flat Girders to its sides.

Construction of the Wagon (Fig. 1)

The underframe of the wagon consists of two 9½" Angle Girders bolted to two 9½" x 2¼" Strip Plates that form its floor. Its sides are also 9½" x 2¼" Strip Plates. These are fixed to 9½" Angle Girders bolted to the floor and strengthened by a 9½" Strip and two 2¼" Angle Girders. The ends are 4½" x 2¼" Flexible Plates. The buffer beams are each made by bolting a 3½" Flat Girder to a 4½" Angle Girder fixed to the end of the floor. The buffers are 1" Pulleys held on Threaded Pins.

The wheels are 2" Pulleys free to turn on 4½" Rods and held in place by Collars.

Each Rod is supported in two Flat Trunnions and in Couplings attached to the Flat Trunnions by ½" Bolts. The dummy springs are each made from a 2¼" and a 1½" Strip fixed to an Angle Bracket held by the same bolt as the Flat Trunnion.

The Operating Mechanism (Figs. 2, 4 and 7)

An E15R Electric Motor is bolted through its flanges to a 5¼" x 2¼" Flanged Plate fixed to the front of the base. Each side-plate of the Motor is extended by a 2¼" x 2¼" Flat Plate, and these are connected by two 1½" x ½" Double Angle Strips. The lower one of these Double Angle Strips is joined to the Flanged Plate by a ½" Reversed Angle Bracket. The inner 2¼" x 2¼" Flat Plate is connected to one of the Girders (4) by a Corner Angle Bracket. The Motor switch is extended outside the base by a Crank bolted to one of its arms.

A ½" Pinion on the Motor armature shaft drives a 57-tooth Gear on a 2¼" Rod that carries also a ½" Pinion (42) (Fig. 4). This Pinion engages a 57-tooth Gear on another 2¼" Rod fitted with a ½" Pinion (43) (Fig. 2), and the latter Pinion drives a 57-tooth Gear on an 11¼" Rod (44) mounted as shown. Rod (44) carries a 1" Sprocket that is connected by Chain to a similar Sprocket on another 11¼" Rod (45).

Each Rod (44) and (45) carries a Worm (40) (Fig. 7), which drives a ½" Pinion on a 2" Rod, and this Pinion engages a 57-tooth Gear (47) on another 2" Rod (Fig. 7). A ½" Pinion is fixed also on this Rod and drives a 50-tooth Gear on a 3" Rod (48). A ½" Sprocket on Rod (48) is connected by Chain to one of the 3" Sprockets (36).

A cover plate in front of the Motor is provided by a 5¼" x 2¼" Flanged Plate (49). Bolts are passed through this Plate into two Threaded Bosses, one of which is fixed by a bolt to a Fishplate bolted to one of the Flanged Plates (2), and the other is held by a bolt in a 3" Strip fixed to one of the 24¼" Angle Girders, and is attached to a flange of the Motor by an Angle Bracket.

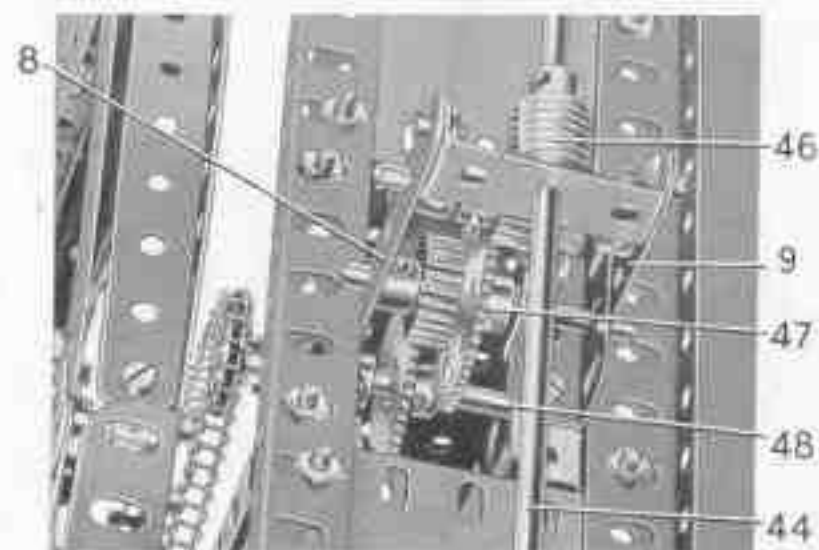

FIG. 7
A detail view of the gearing below one of the supporting columns

Parts Required to Build the Meccano Model Coal Tippler

12 of No. 1	6 of No. 8a	8 of No. 12c	4 of No. 20a	2 of No. 45	2 of No. 64	2 of No. 96a	22 of No. 111c	4 of No. 190a	2 of No. 226
6 " " 1a	4 " " 8b	2 " " 13	4 " " 22	4 " " 48	4 " " 70	4 " " 103	4 " " 115	16 " " 191	
6 " " 1b	12 " " 9	1 " " 13a	2 " " 25	4 " " 48a	2 " " 72	4 " " 103a	3 " " 125	30 " " 192	
35 " " 2	6 " " 9a	4 " " 14	5 " " 36	2 " " 48b	2 " " 71	2 " " 103b	4 " " 126a	4 " " 196	
8 " " 2a	4 " " 9b	2 " " 15a	2 " " 27	4 " " 52	4 " " 76	2 " " 103c	2 " " 128	10 " " 197	
15 " " 3	8 " " 9c	2 " " 16	5 " " 27a	6 " " 52a	2 " " 81	2 " " 103d	2 " " 131a	1 " " 198	
11 " " 4	6 " " 9f	2 " " 16a	2 " " 32	6 " " 53	2 " " 82	3 " " 103f	2 " " 136a	4 " " 214	
21 " " 5	14 " " 10	2 " " 16b	4 " " 35	4 " " 53a	12 " " 89	4 " " 103k	1 " " 154a	4 " " 221	
10 " " 6a	12 " " 11	4 " " 17	620 " " 37a	1 " " 58	8 " " 89b	4 " " 108	2 " " 179	2 " " 222	1 E15R
4 " " 7	21 " " 12	2 " " 18a	565 " " 37b	22 " " 59	2 " " 94	4 " " 109	12 " " 186	2 " " 223	Electric Motor
8 " " 7a	8 " " 12a	1 " " 18b	74 " " 39	1 " " 62	4 " " 93b	6 " " 111	12 " " 189	2 " " 224	(not included
13 " " 8	4 " " 12b	2 " " 20	4 " " 38d	0 " " 63	2 " " 96	6 " " 111a	16 " " 190	2 " " 225	in Outfit)