

Gabriel®

# ERECTOR

Building Instructions for Sets 200, 375, 500, 725





## ERECTOR MEANS BUILDING

Your Erector® Construction System will provide you with many hours of building excitement. Whether you're building the models in this book or creating your own, there's lots of discovery and fun with Erector. This book contains model plans for all four Erector sets. The models in this book that you can build depend on what set you have.



Erector 200—build models on pages 8-14

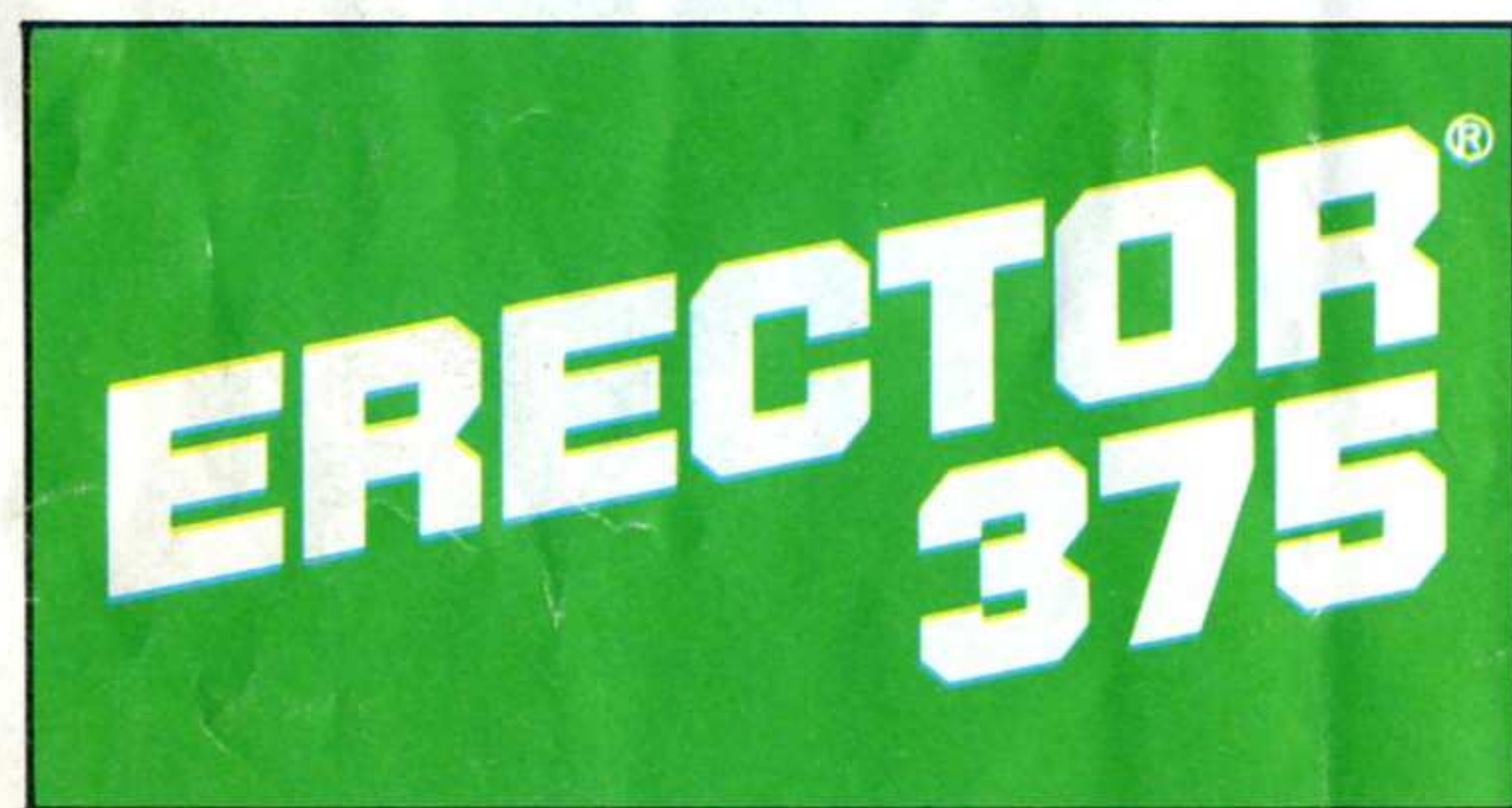

Erector 375—build models on pages 8-20



Erector 500—build models on pages 8-28



Erector 725—build models on pages 8-41

## HOW THIS BOOK WORKS

First, read through this introduction carefully. It will explain the way the pieces go together and other important things you'll need to know such as: attaching the wheels, connecting the motors, and making your models move. When you're ready to start building, pick a model you can build with your set and simply follow the pictures.

## BASIC ASSEMBLY TECHNIQUES

### Nut & Screw Assembly

Your Erector models are mostly put together with nuts and screws. Put the screw through the 2 or more parts you want to connect. Fit a nut on the end of the screw and tighten by turning the screw clockwise. Use the screwdriver to turn the screw, and the wrench to hold the nut in place.

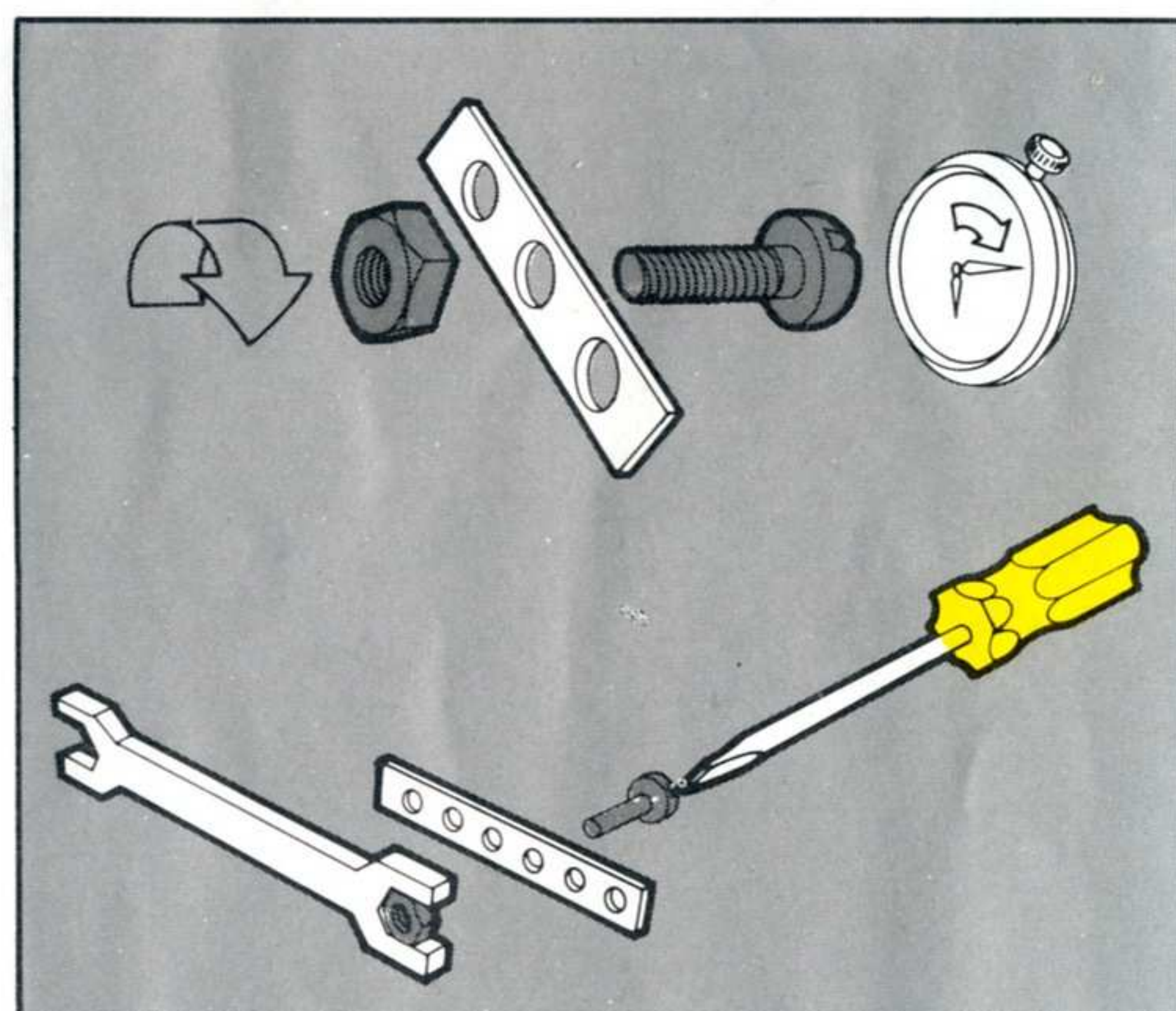

You have 4 different length screws. Most of the time use the No. 2 screw. Use No. 3 or No. 4 screws when you need a longer one. Use the No. 1 screw only with the disc or pulley to hold axles in place.

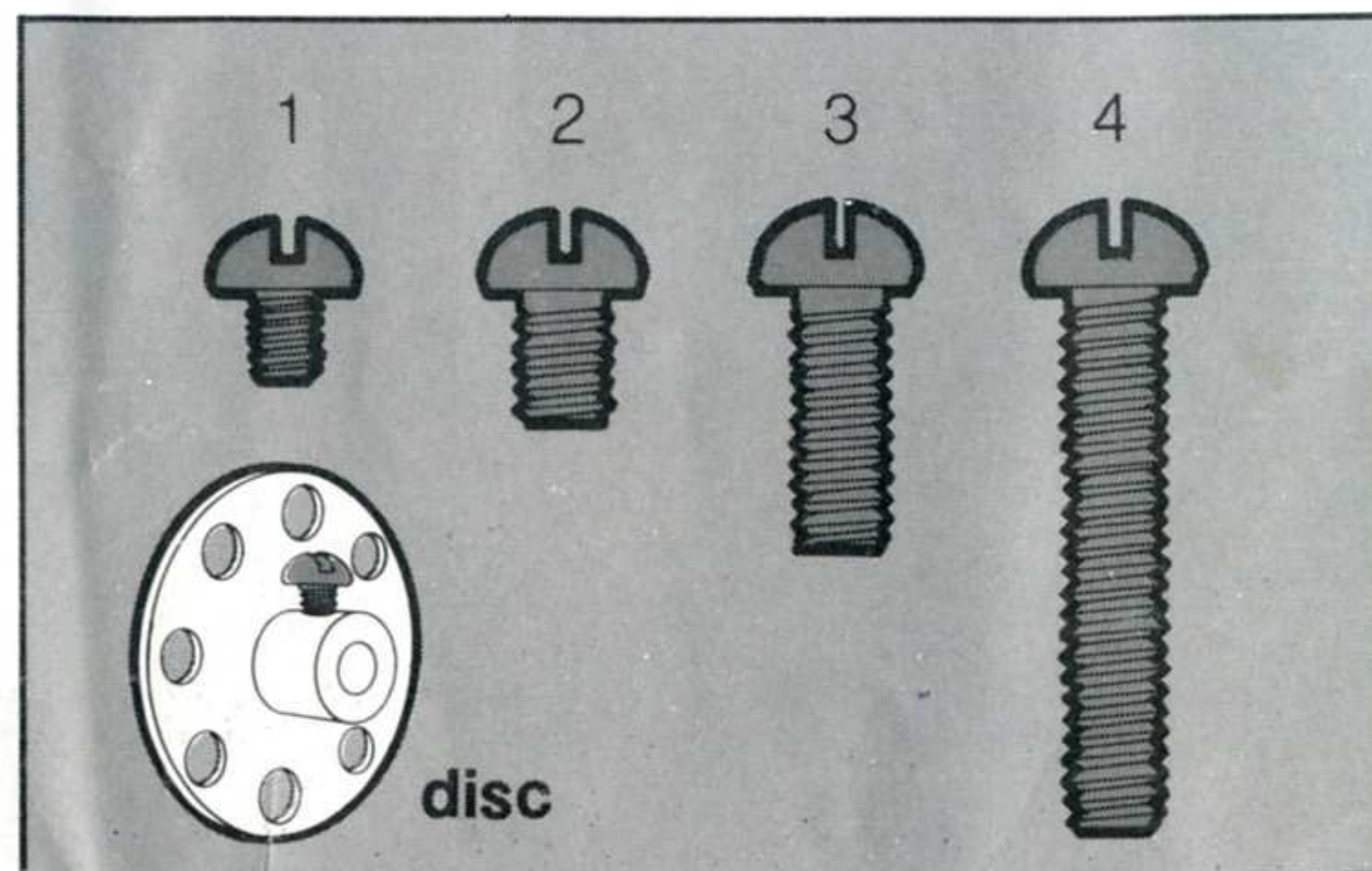

### Axles

The axles are pieces that hold the wheels in place on the chassis and turn the wheels. There are 4 different sizes of axles, but you may not have all 4 in your set. Use the chart to sort your axles.

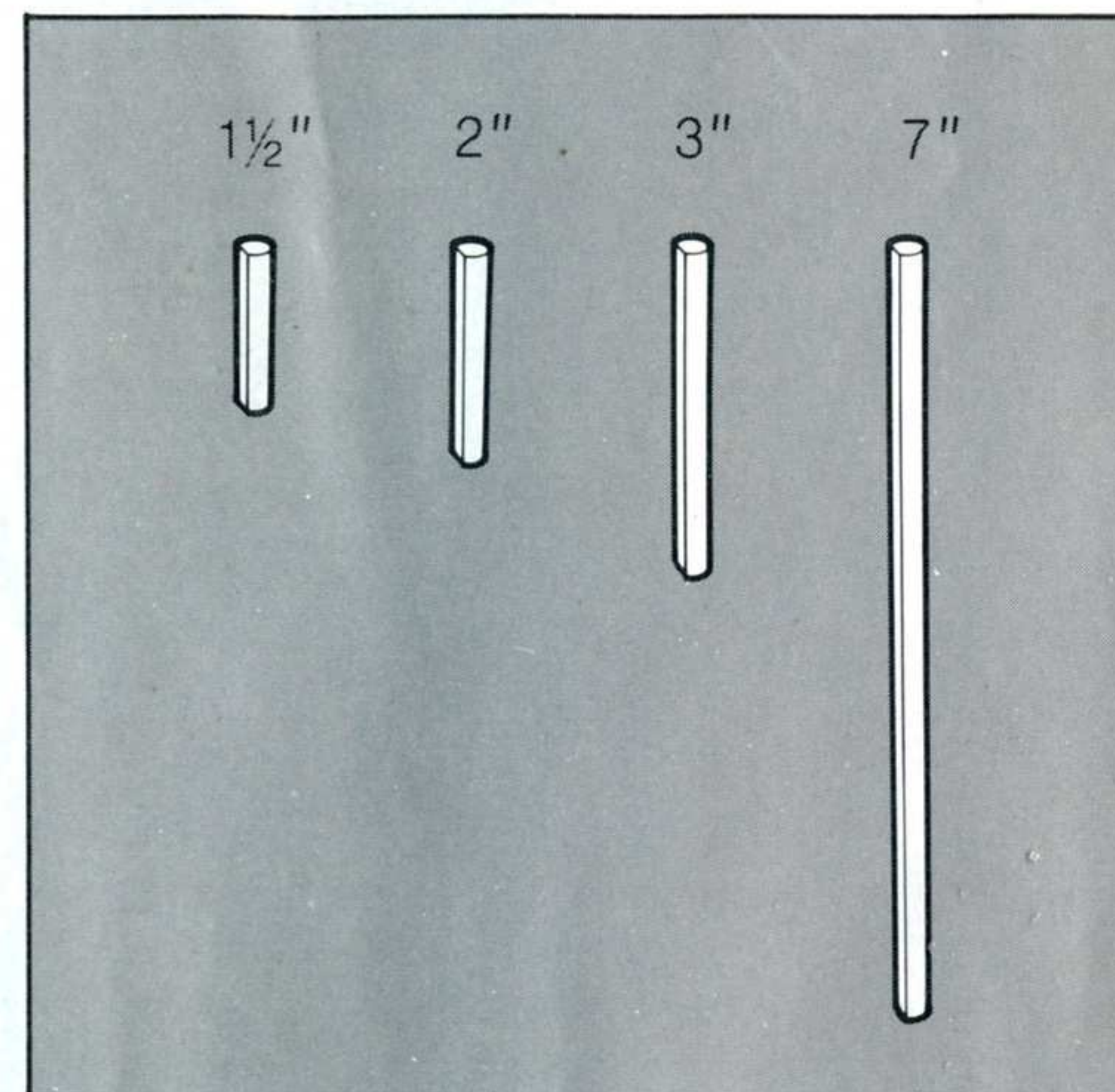

### Tires and Hubs

Slide the hubs inside the tire. Fit the flat surface of each hub together, then slide an axle through the hub and tire. Add hub cap.

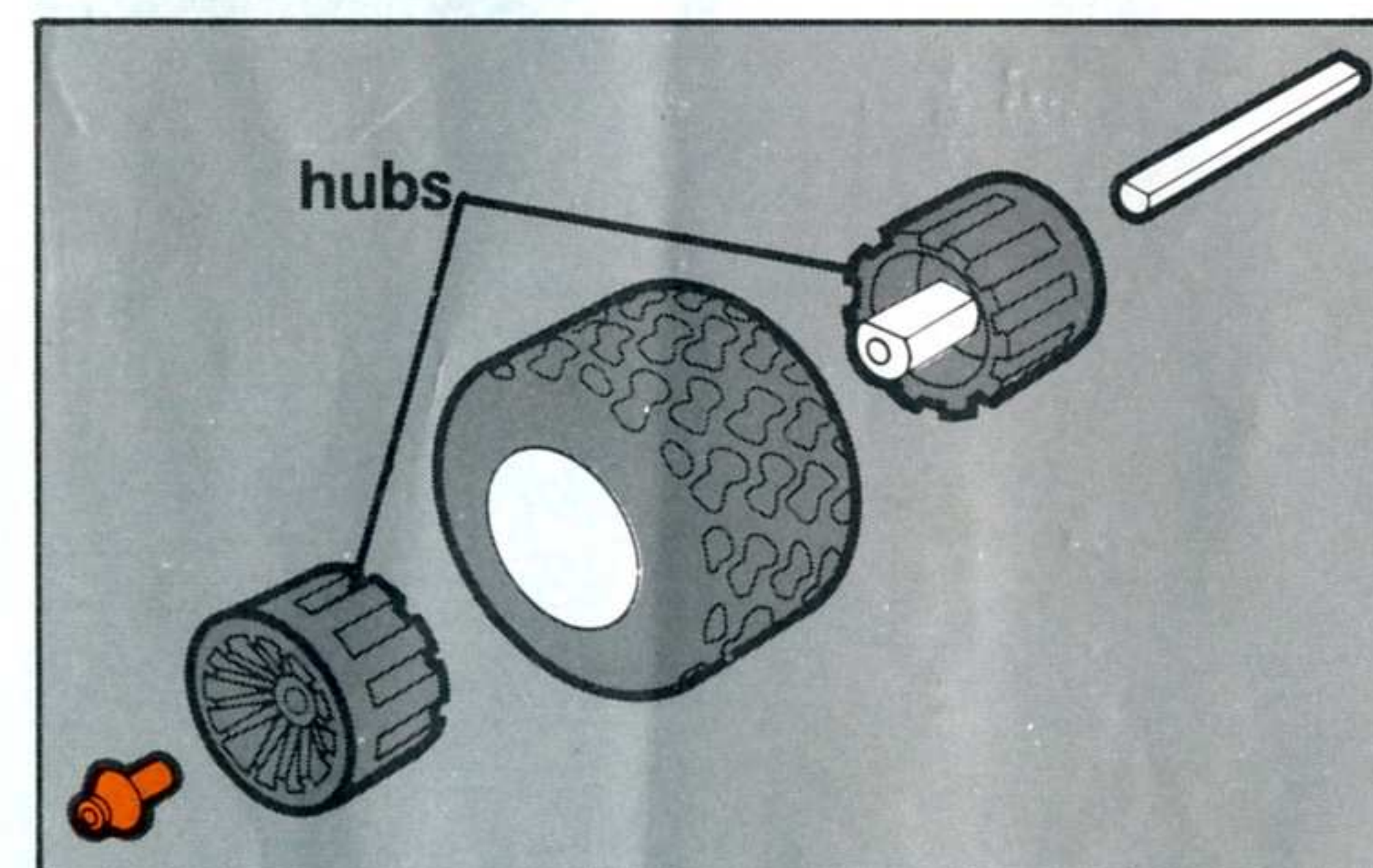

For the small tires (in sets 500 and 725), snap hubs together and slip rubber tires over them. Put in the axles, and add the hub caps.

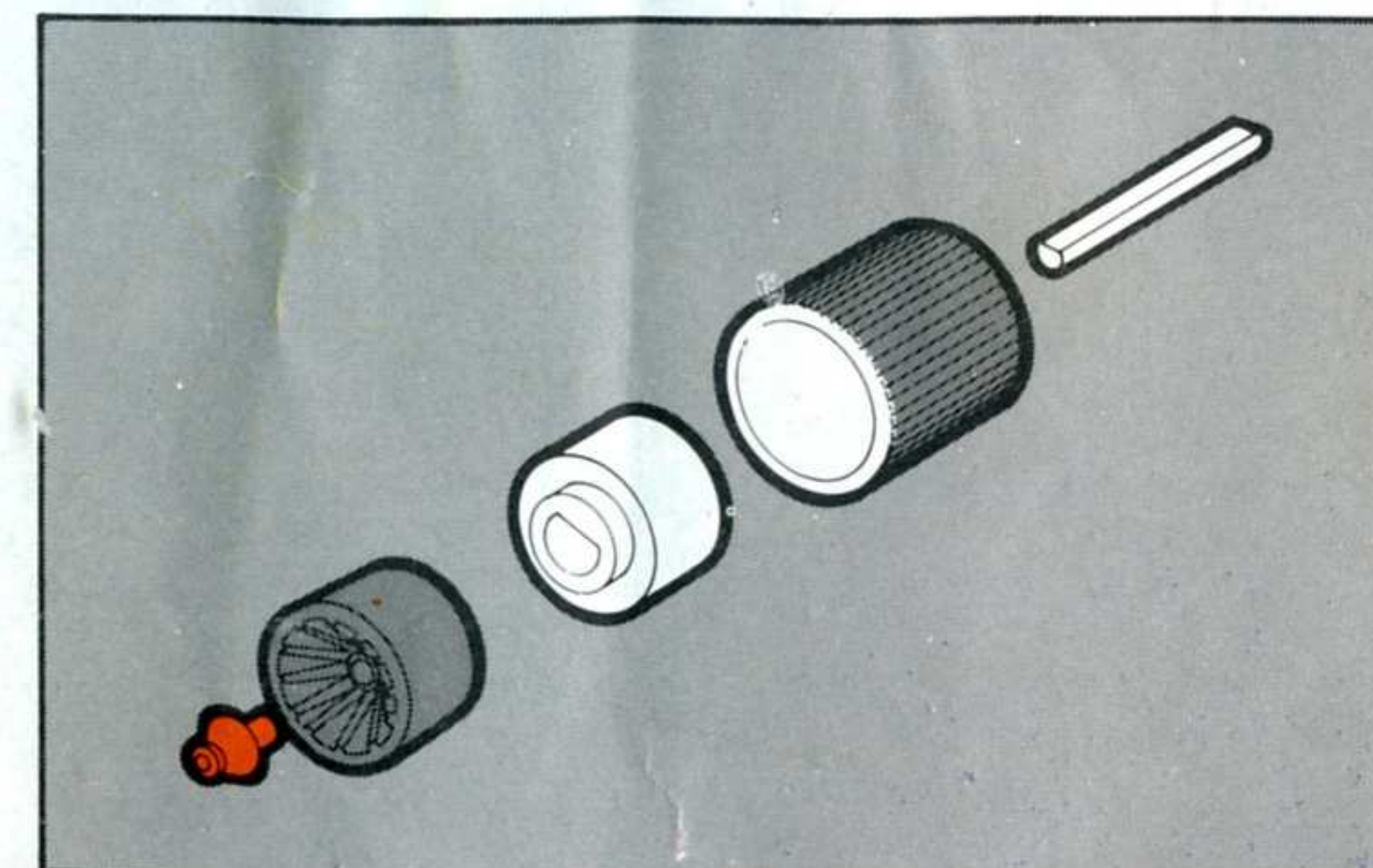

## ATTACH WHEELS TO CHASSIS

Axle supports connect the axles to the chassis. Snap axle support in place as shown. Be sure that the flat side of the axle support fits against the inside wall of the chassis. Put axle through the support and hold it in place by snapping a clip over the axle.

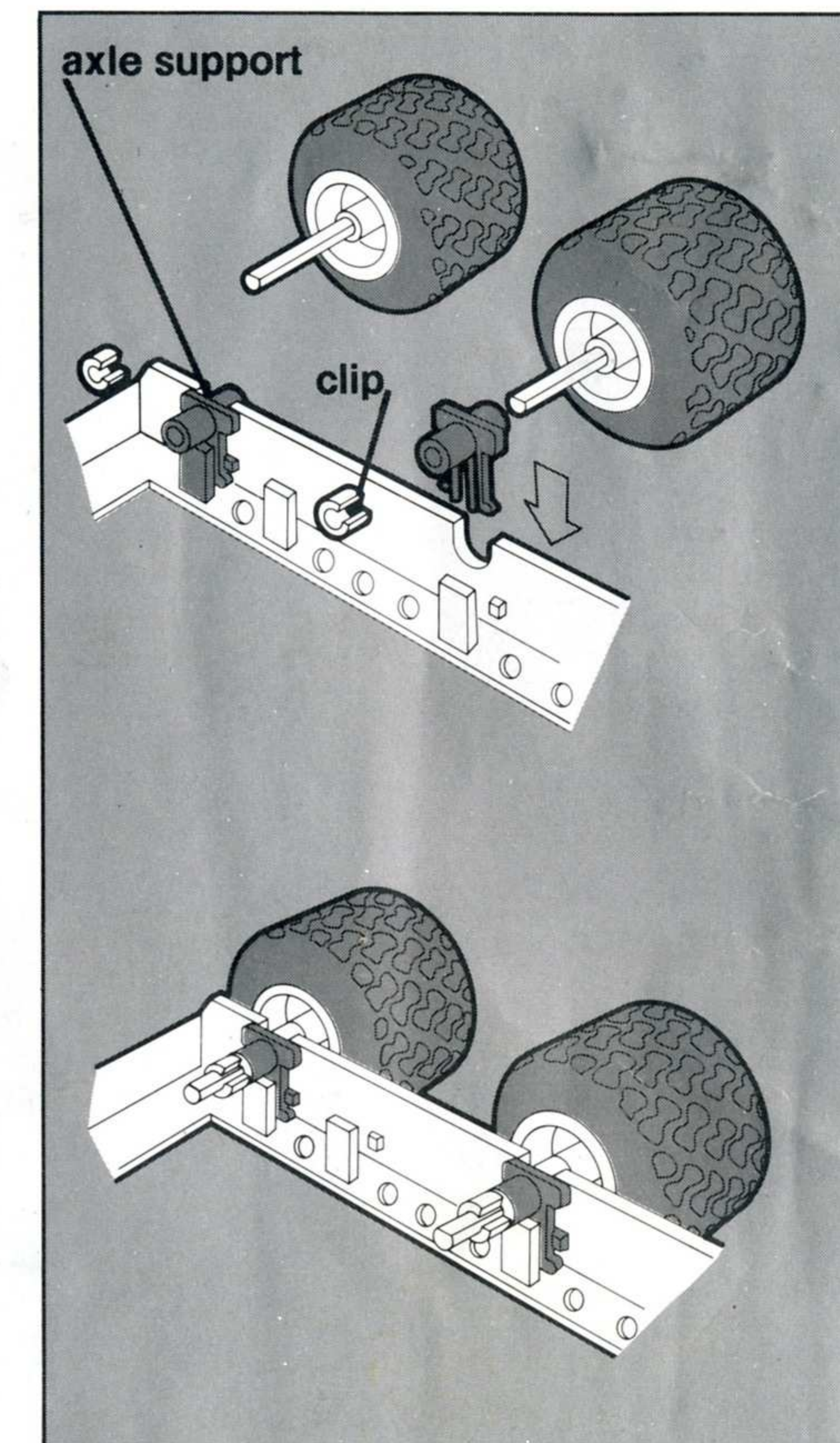

## HYDRAULIC UNIT

Snap together as shown.

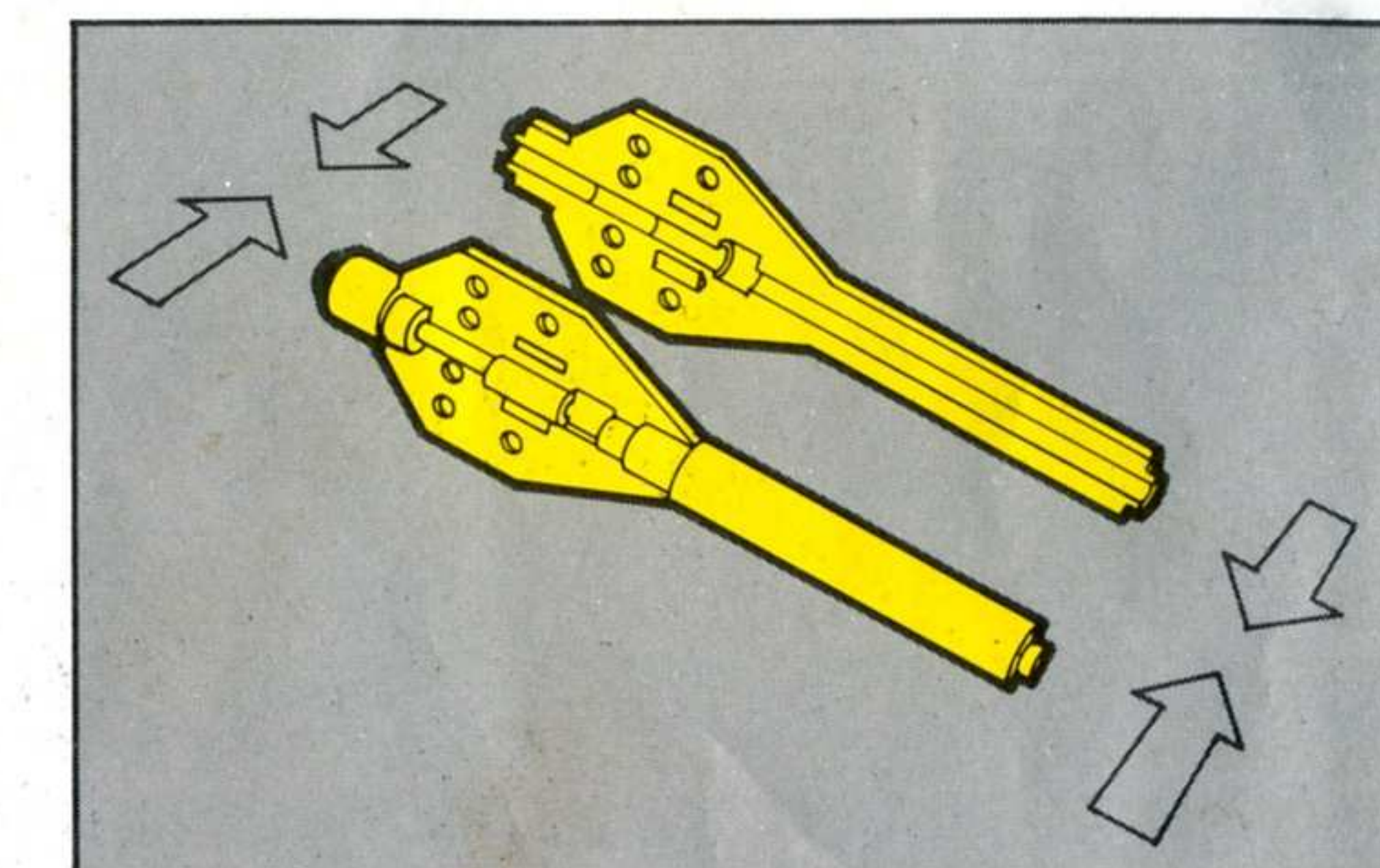



## MOTORIZED BUILDING TECHNIQUES BATTERY BOX (Set 375)

Put 2 D-cell batteries in battery box as shown.

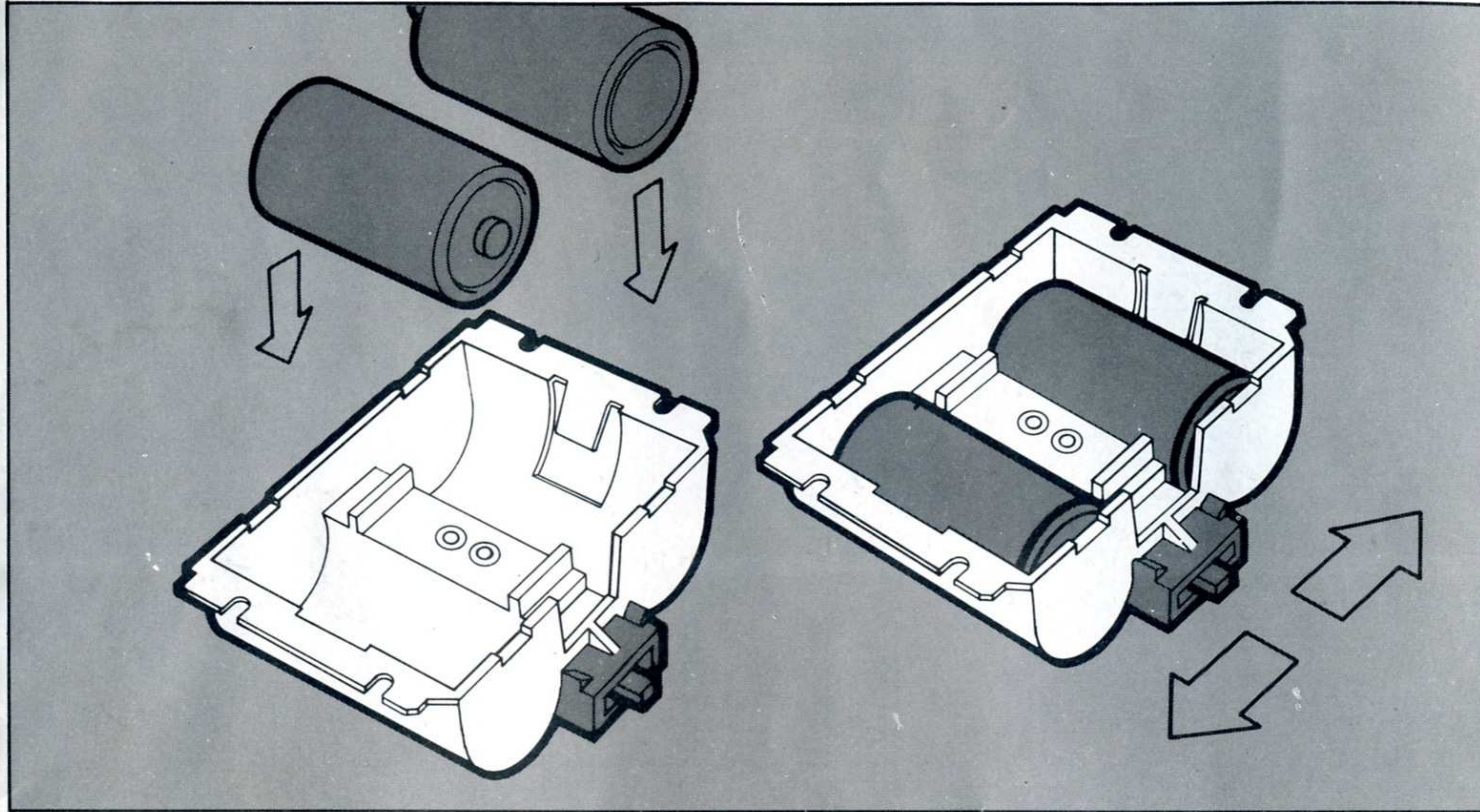

## REMOTE CONTROL UNIT (Sets 500 and 725)

Slide the doors off. Put in two D-cell batteries as shown. Replace the doors.

Put 1 D-cell battery in the back compartment

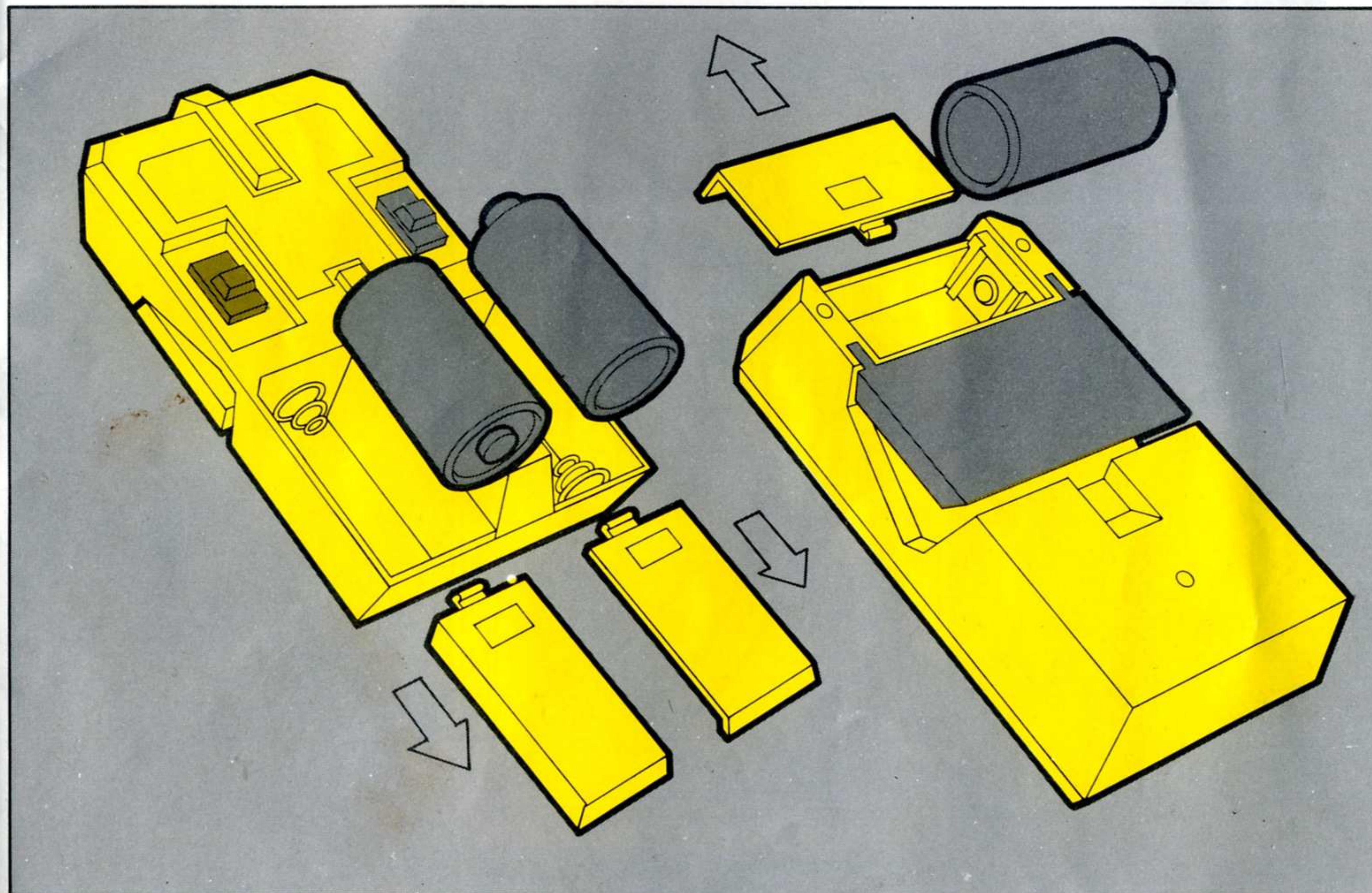

## ATTACH MOTORS TO CHASSIS

Place the motor in the chassis as shown. Fit the notches in the motor over the tabs in the chassis. To be sure you put the motor in right, match the colored notch to the colored tab as in the picture.

## ATTACH BATTERY BOX (Set 375)

Follow the same steps with the battery box that you did for the motor.

Be sure that the notches fit over the correct tabs.

Be sure that motors are facing in the right direction.

Be sure you're pushing the motor in the right direction.

Be sure that motor locks in place.

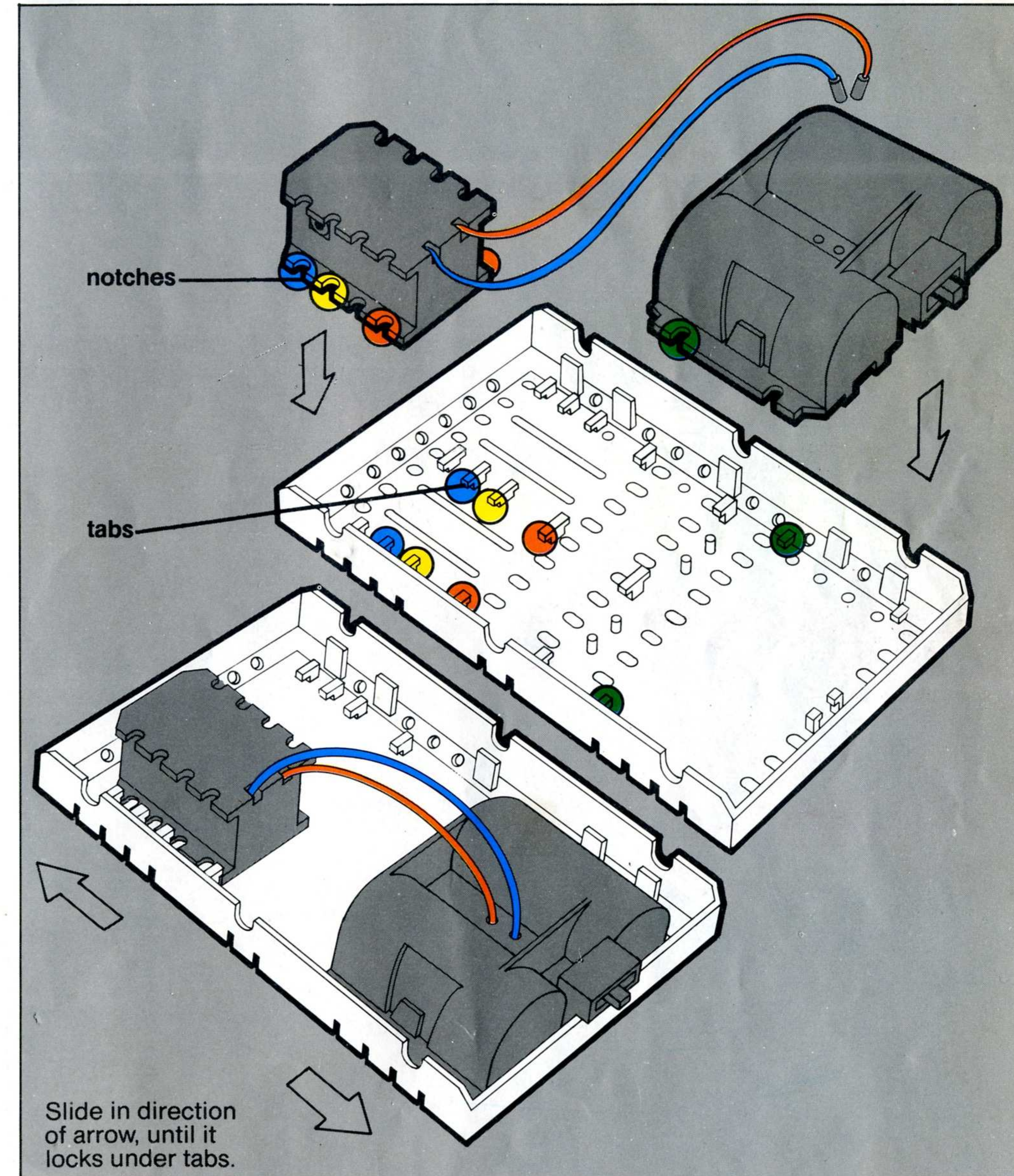



## USING MOTORS IN THE CENTER POSITION

Some models use the motors in the center position. Put them in as shown. Make sure they lock in place and sit up against the pins. When you have the motors in this position, you will need to use the special axle supports

to connect the wheels to the motors. There are only two of them in your set (as shown). Twist them off the runners and snap into place on the chassis.

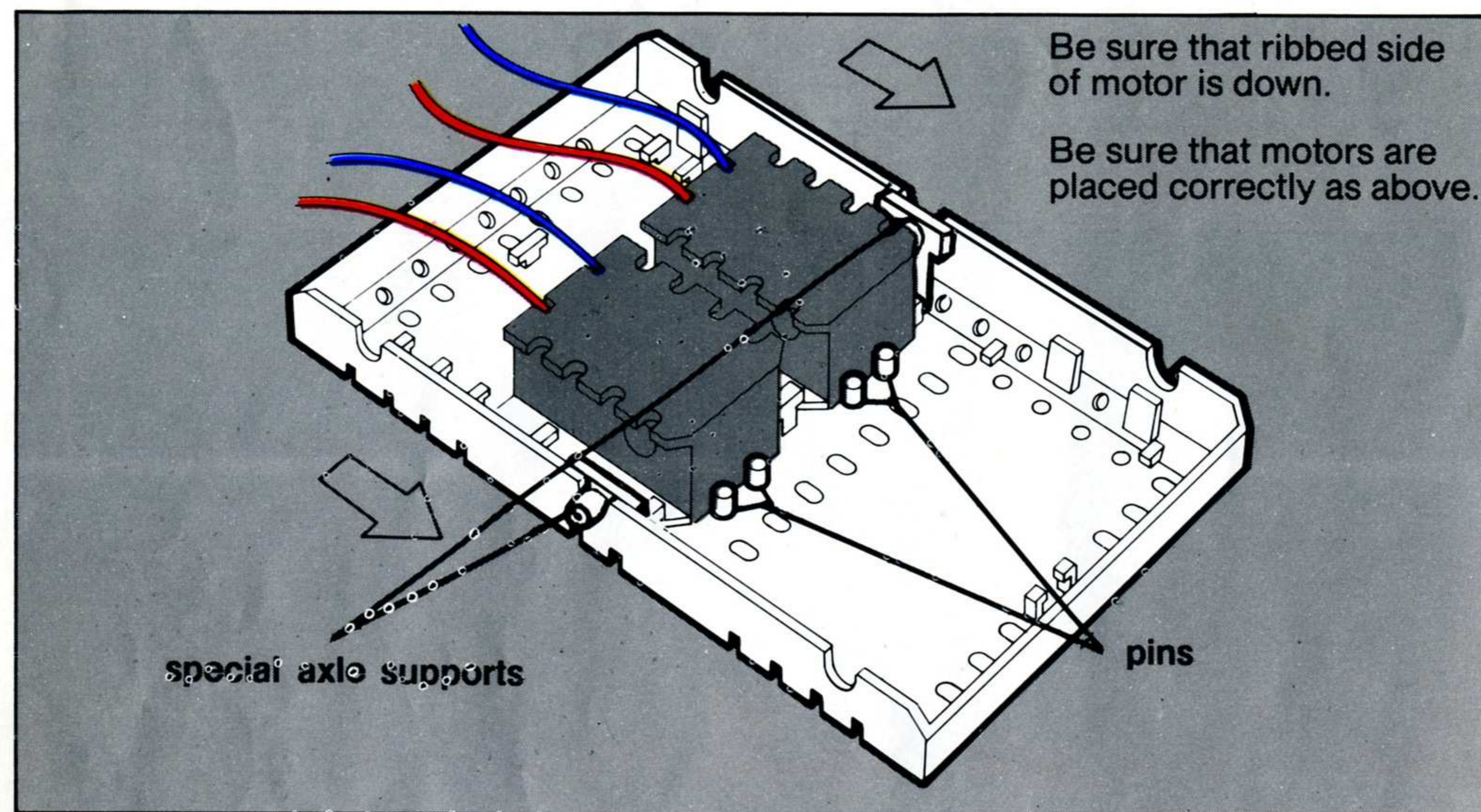

## SUGGESTED CHASSIS HOOK-UPS WITHOUT MOTORS

(4) wheels, (1) 7" axle, (2) 2" axles

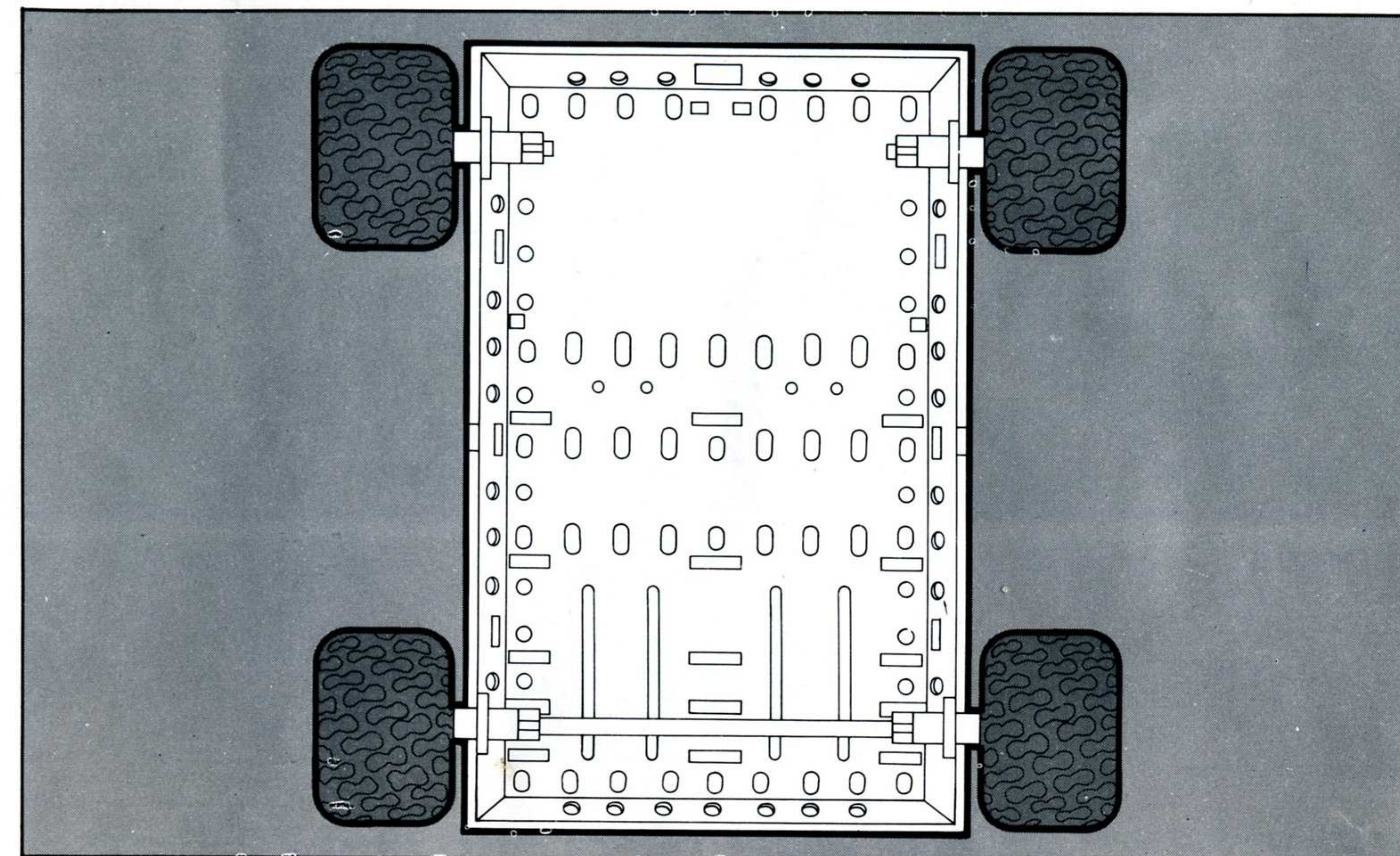

## CONNECTING AXLES TO MOTORS

Match the flat side of the axle to the flat side of the hole in the motor. Push axle into motor.

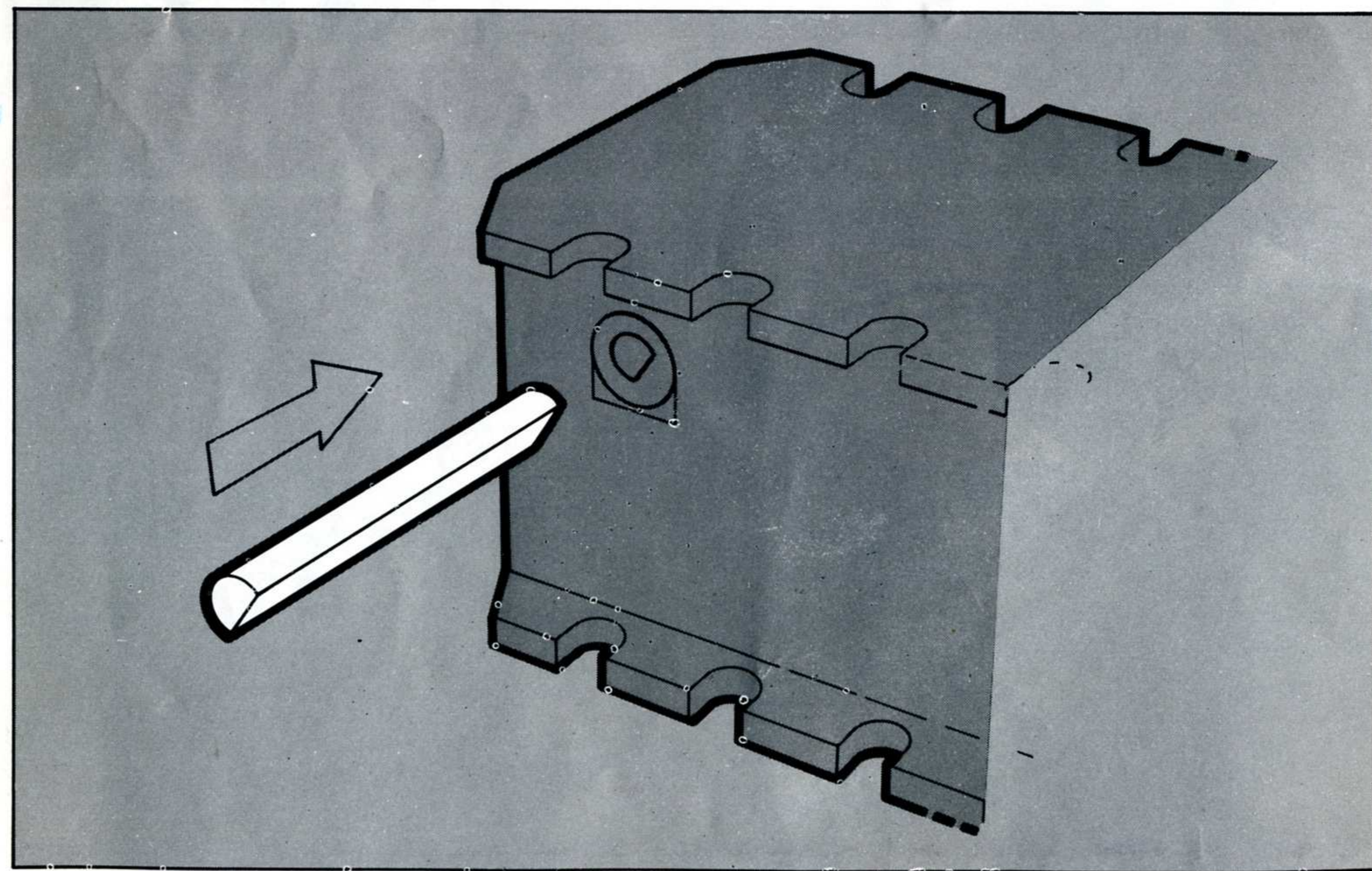

## WITH MOTOR AND BATTERY BOX

(6) wheels, (1) 7" axle goes through motor, (2) 2" axles in center, (2) 1 1/2" axles on either side of battery box.

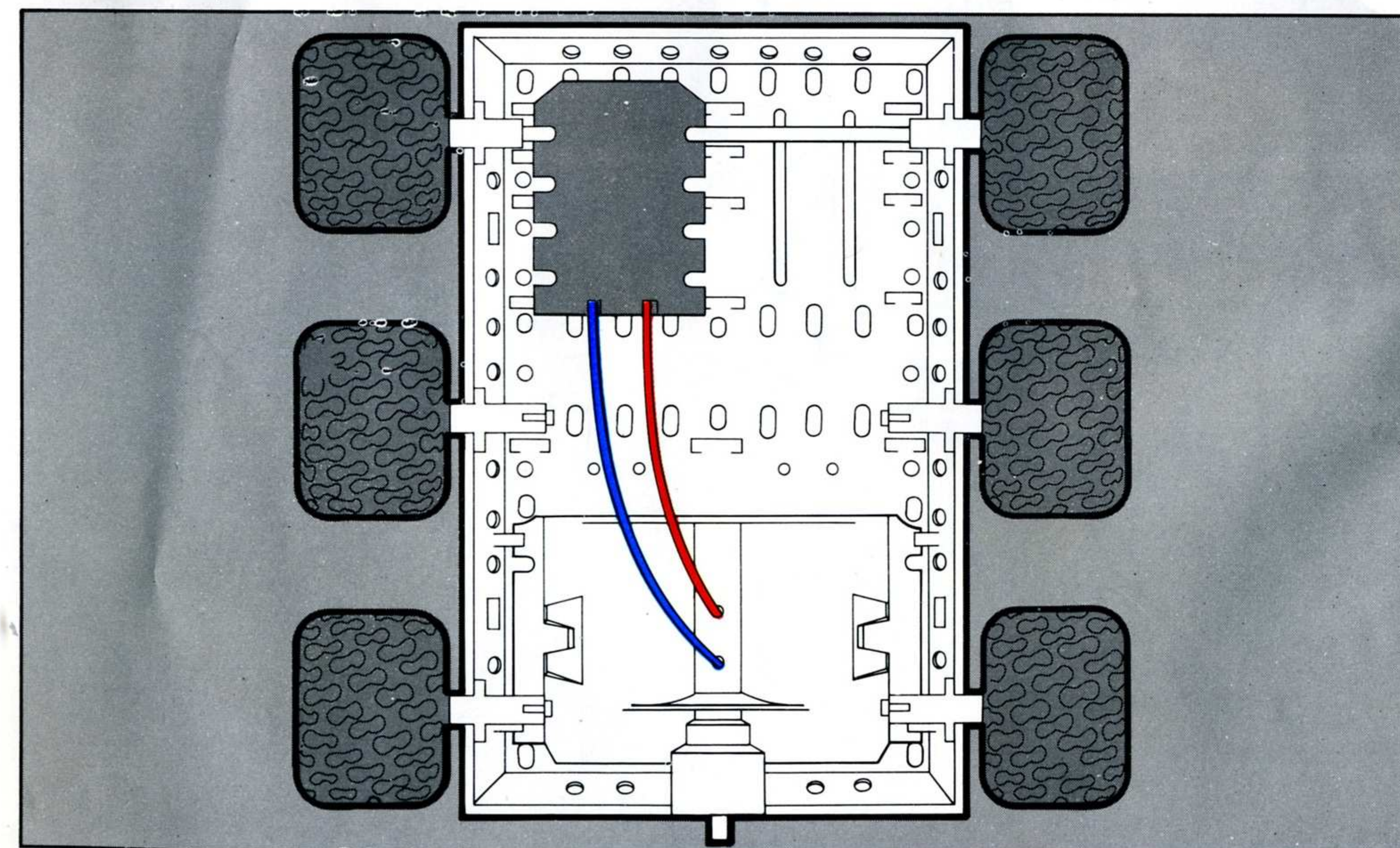



## WITH 2 MOTORS IN CENTER POSITION

(6) wheels, (6) 2" axles. Use special axle supports for center wheels.

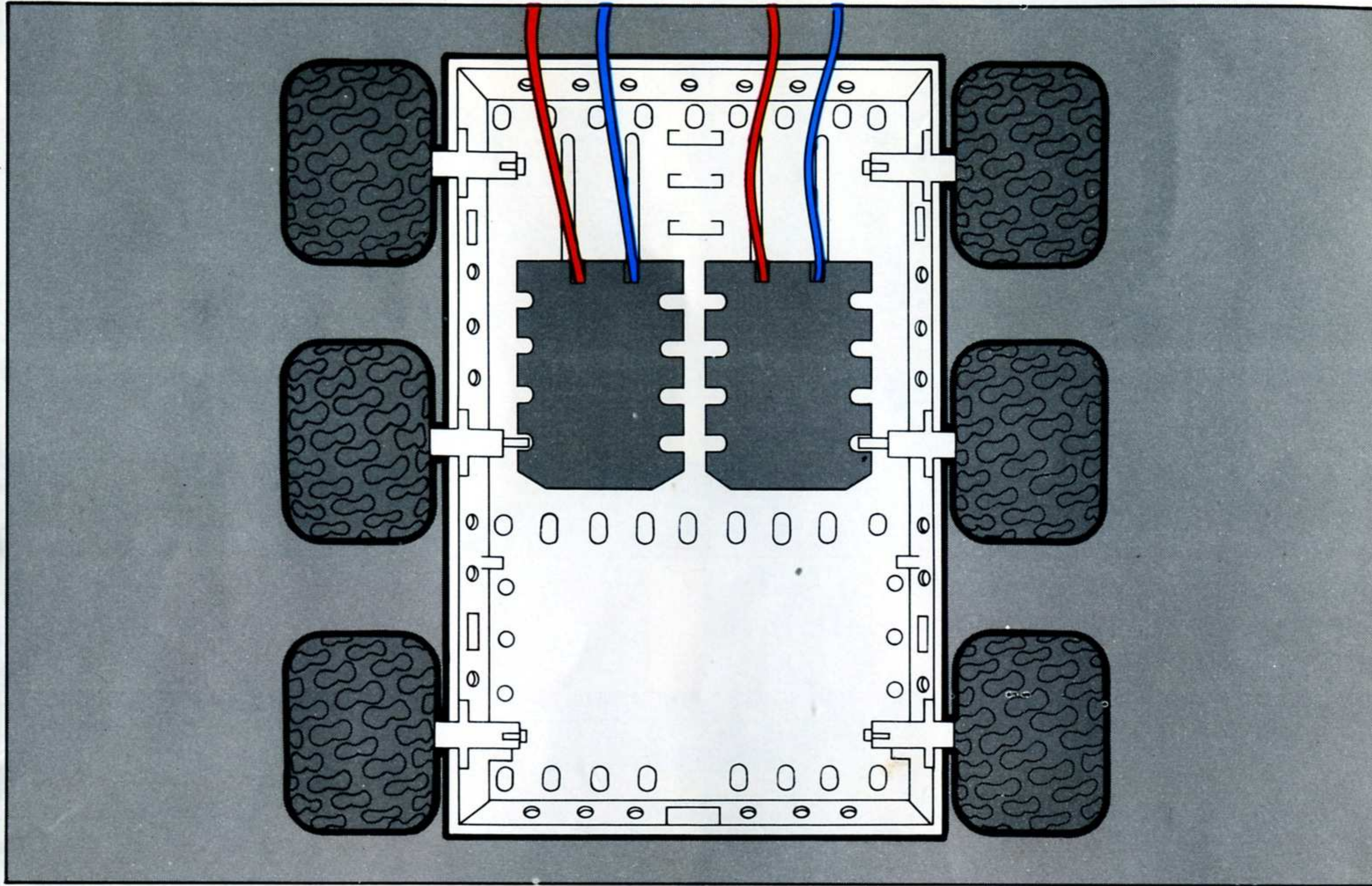

## WITH 2 MOTORS IN REAR POSITION

(6) 2" axles.

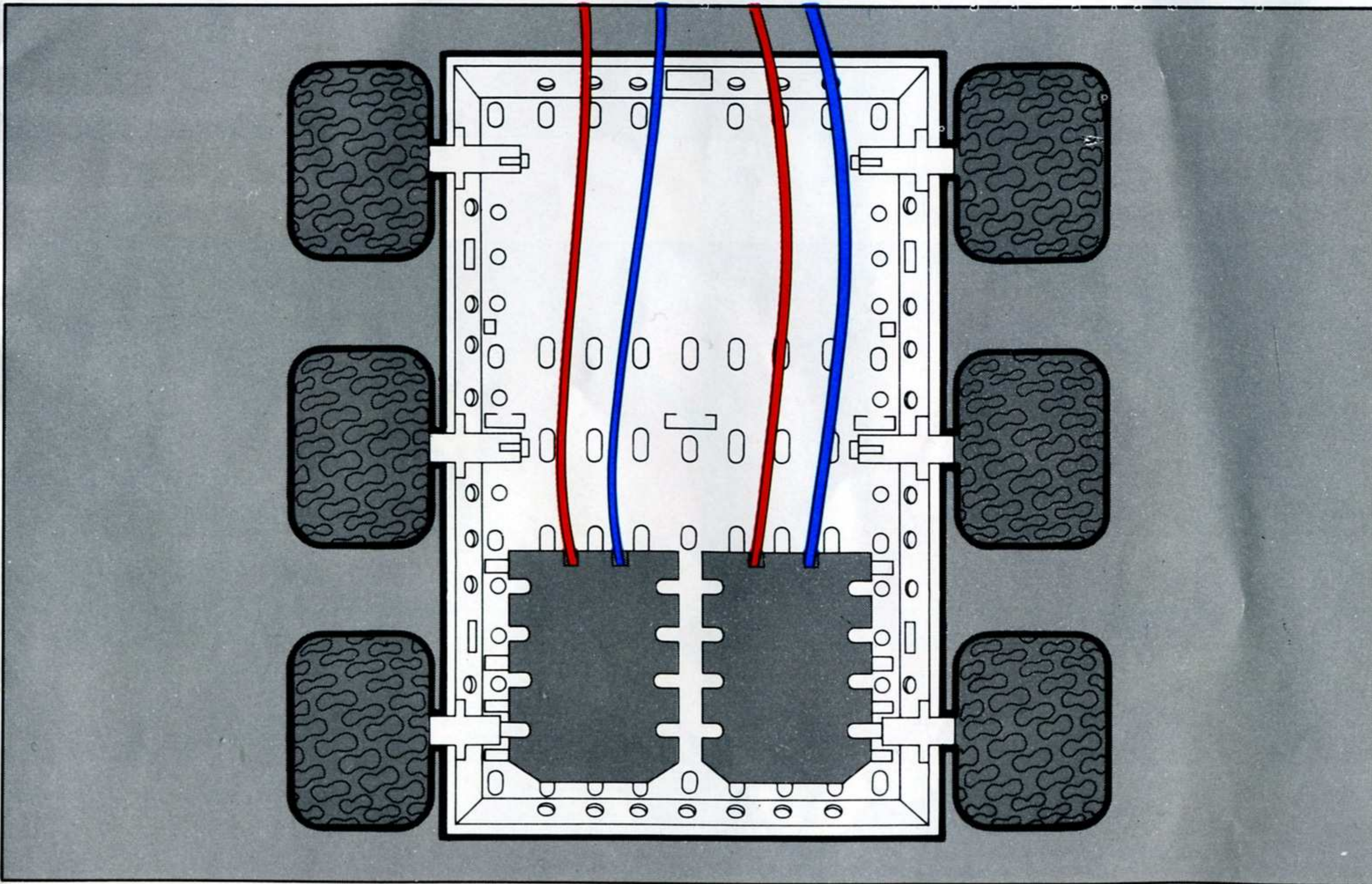

## WITH 2 MOTORS IN SMALL CHASSIS (Set 725 only)

(8) 2" axles.

NOTE: The 2 chassis are joined by the link.  
Snap it to the chassis as shown.

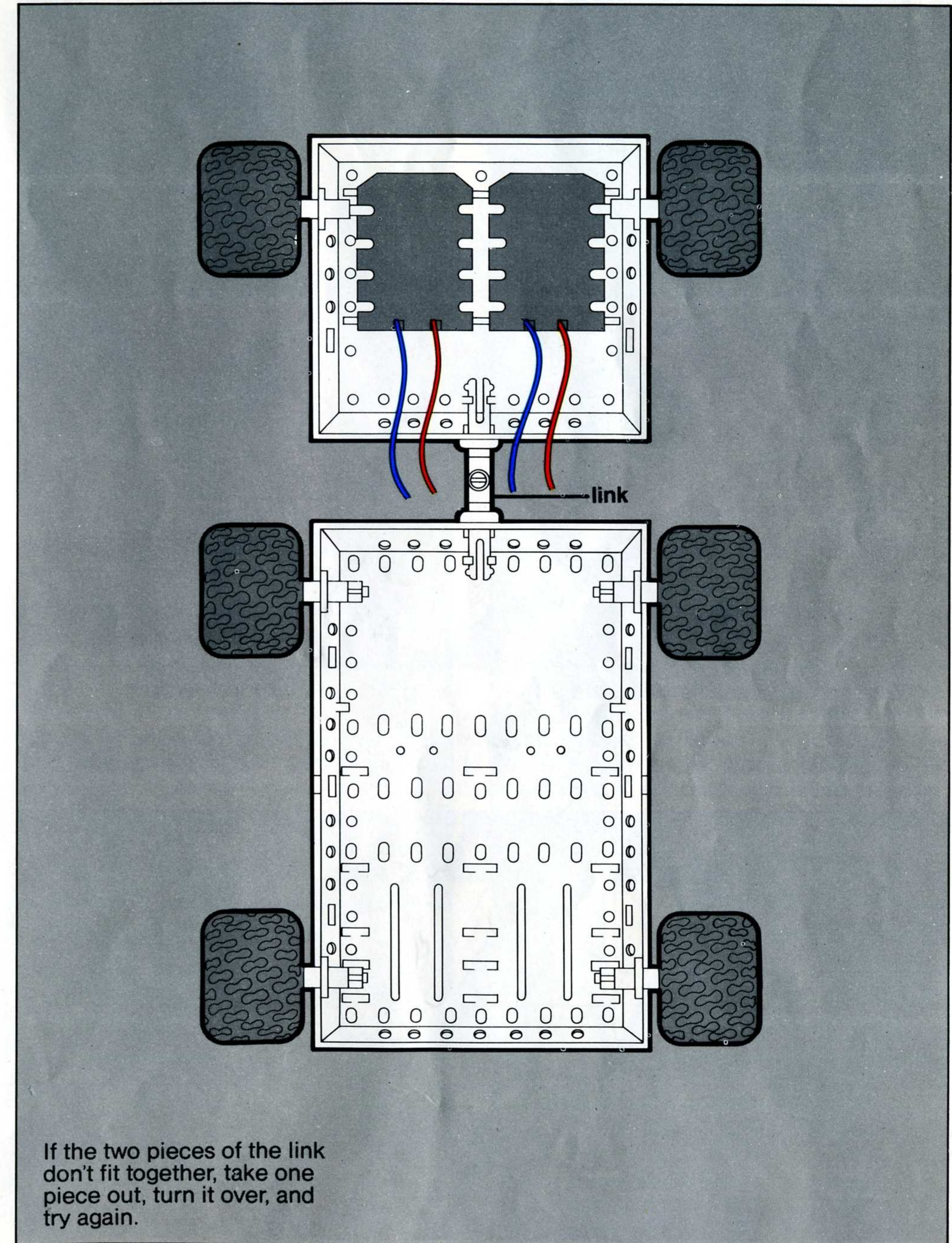

If the two pieces of the link don't fit together, take one piece out, turn it over, and try again.



## REMOTE CONTROL

The orange and yellow wires coming from the Remote Control Unit are controlled by the right hand switch on the unit and should be connected to the right motor.

The green and blue wires coming from the Remote Control Unit are controlled by the left hand switch on the unit and should be connected to the left motor.

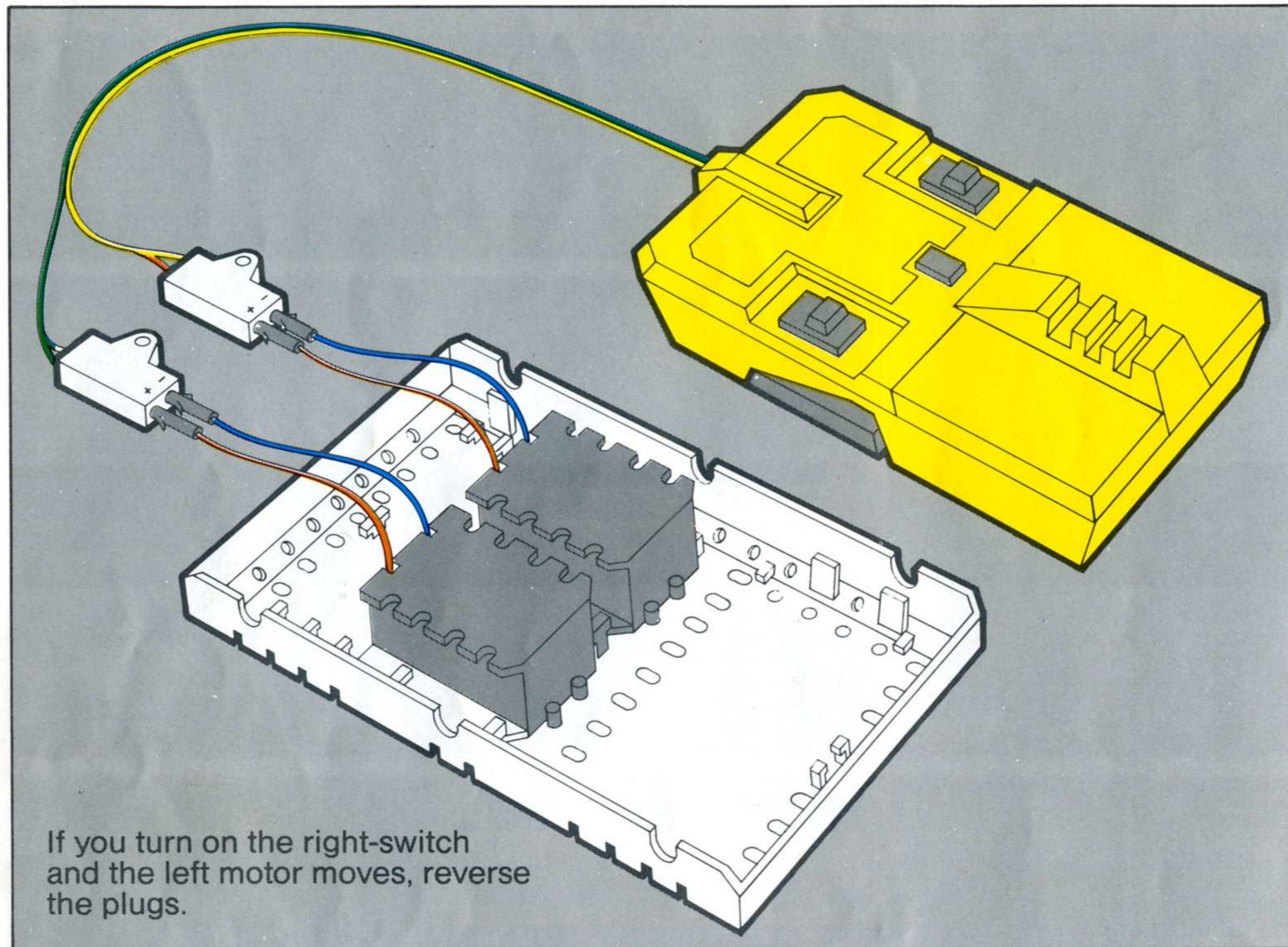

Look at the black plugs on the ends of the remote control wires. They are marked "+" (positive) and "-" (negative). Start by connecting the red wires from the motors to the "+" sides of the plugs and the blue wires to

the "-" sides. If your model doesn't move the way you want it to when you turn on the motors, reverse the connections. (Plug the blue wires into the "+" and the red wires into the "-.")

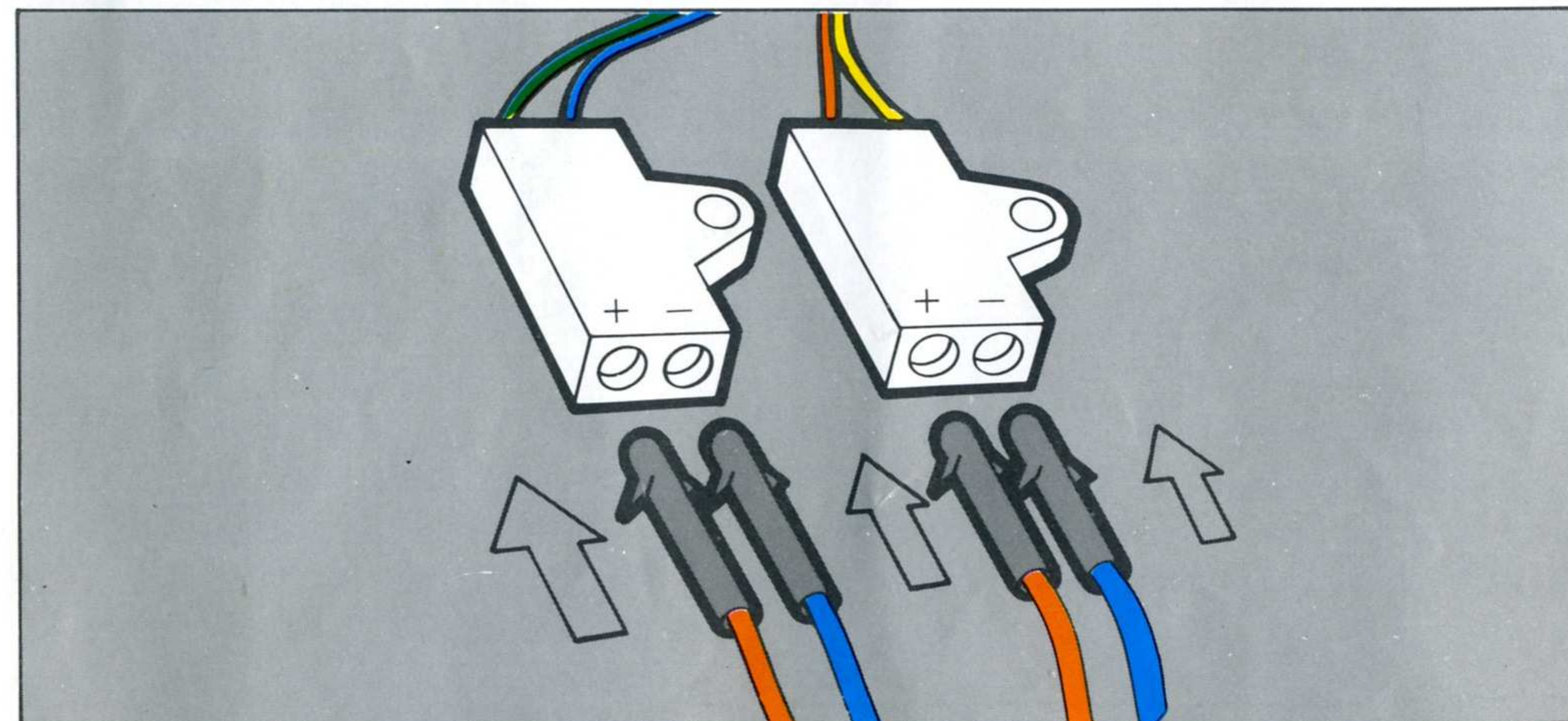

The switches on the top control the direction the motors run.

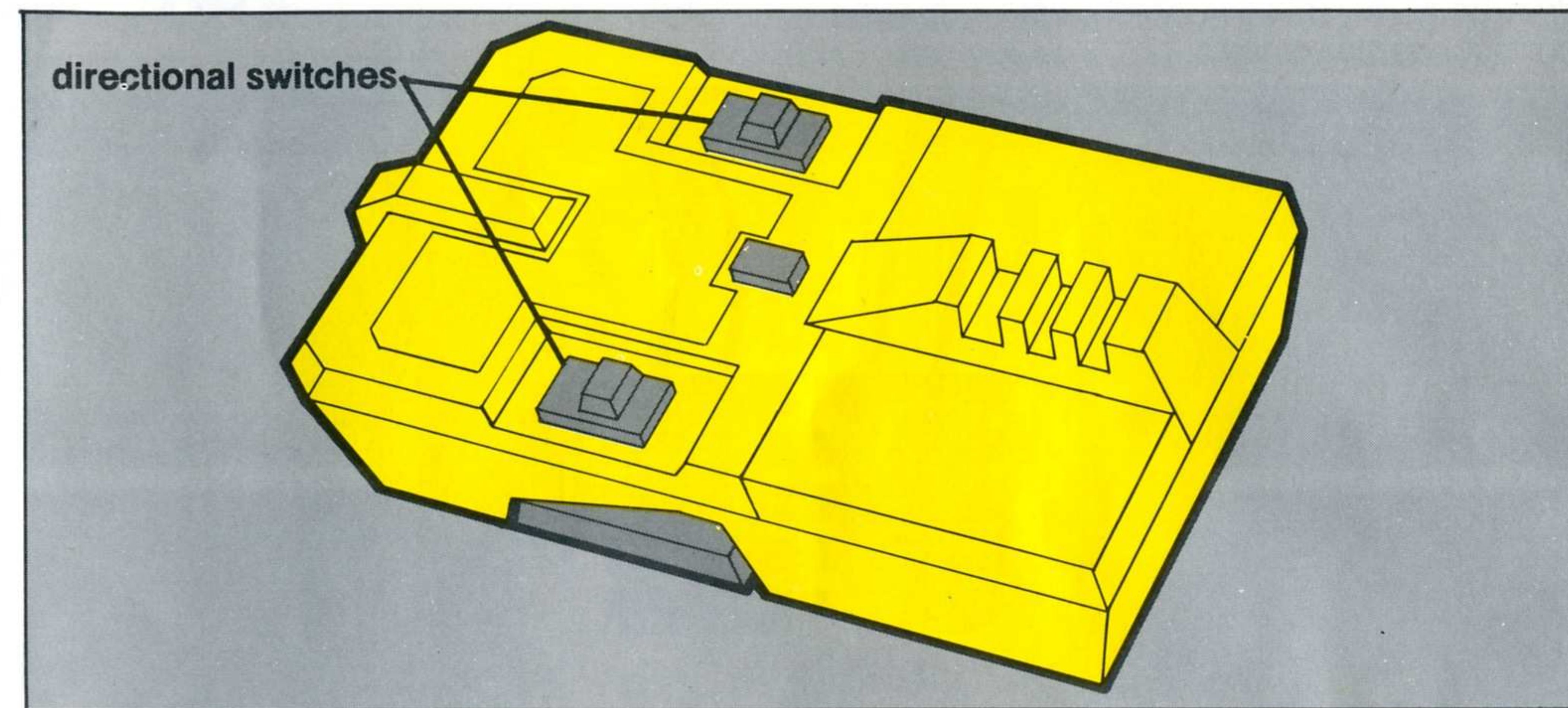

The lever on the bottom varies the speed. The Speed-Lock switch on the top locks the motors on in the fastest setting.

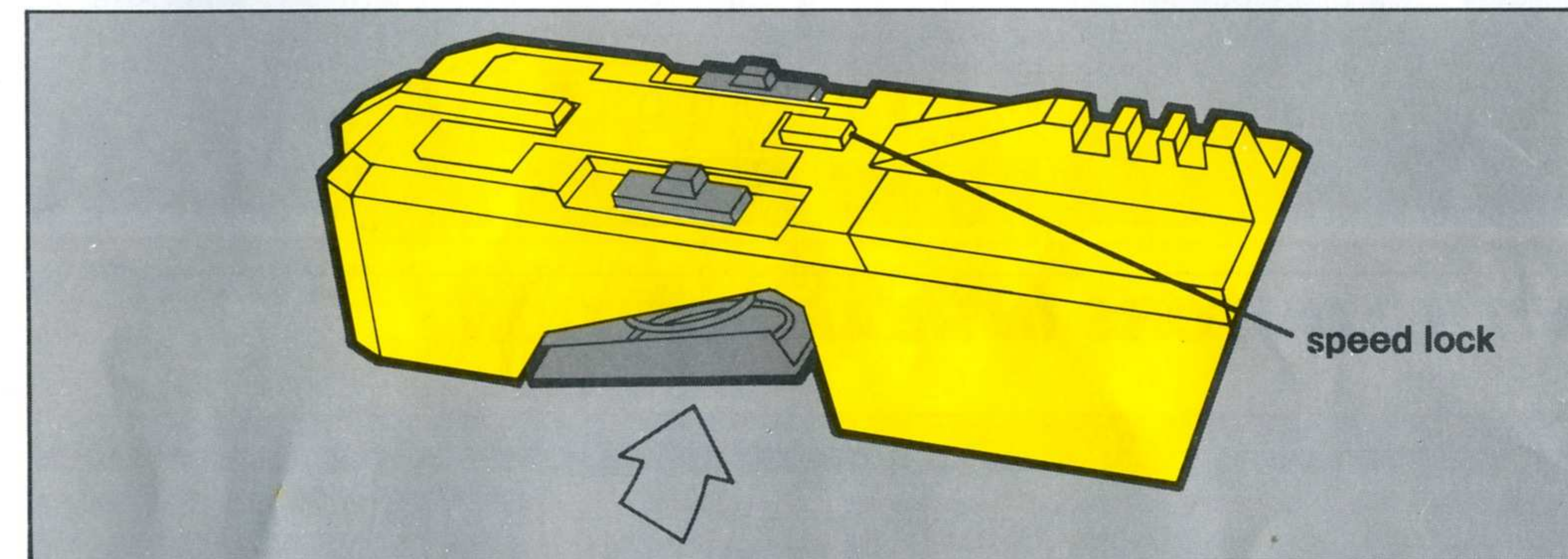

Attach remote control plugs to models as shown using a screw and a nut.

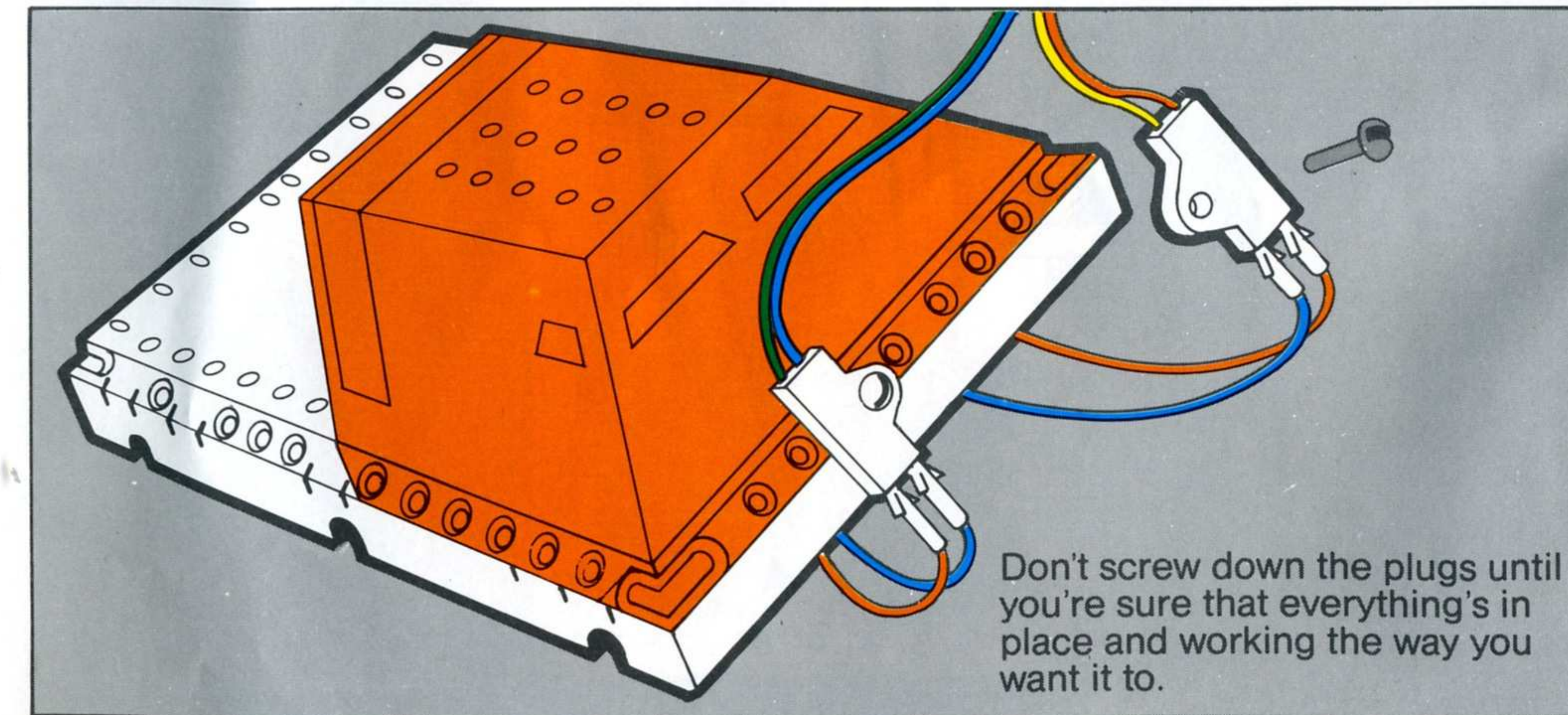



## DRIVING BOTH SWITCHES IN "FORWARD"

Model moves ahead fast.

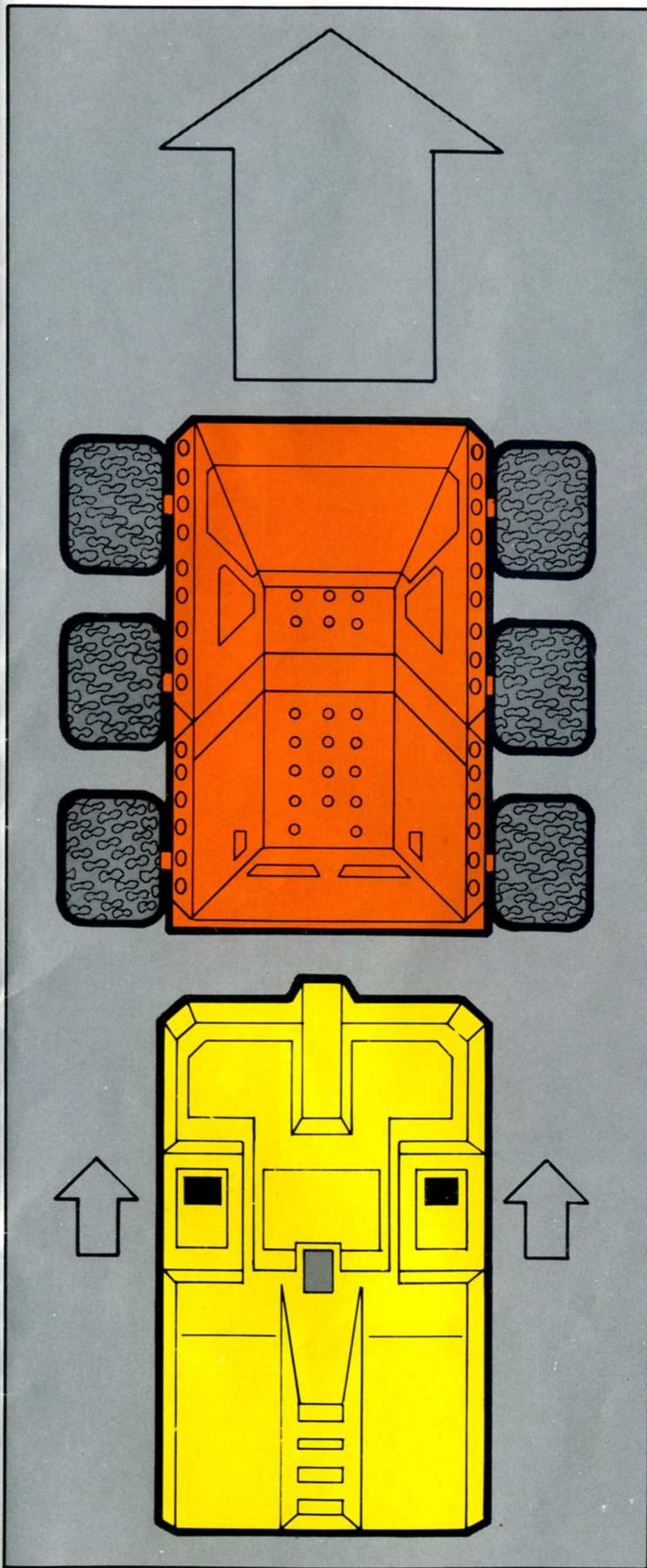

## BOTH SWITCHES IN "REVERSE"

Model moves backwards fast.

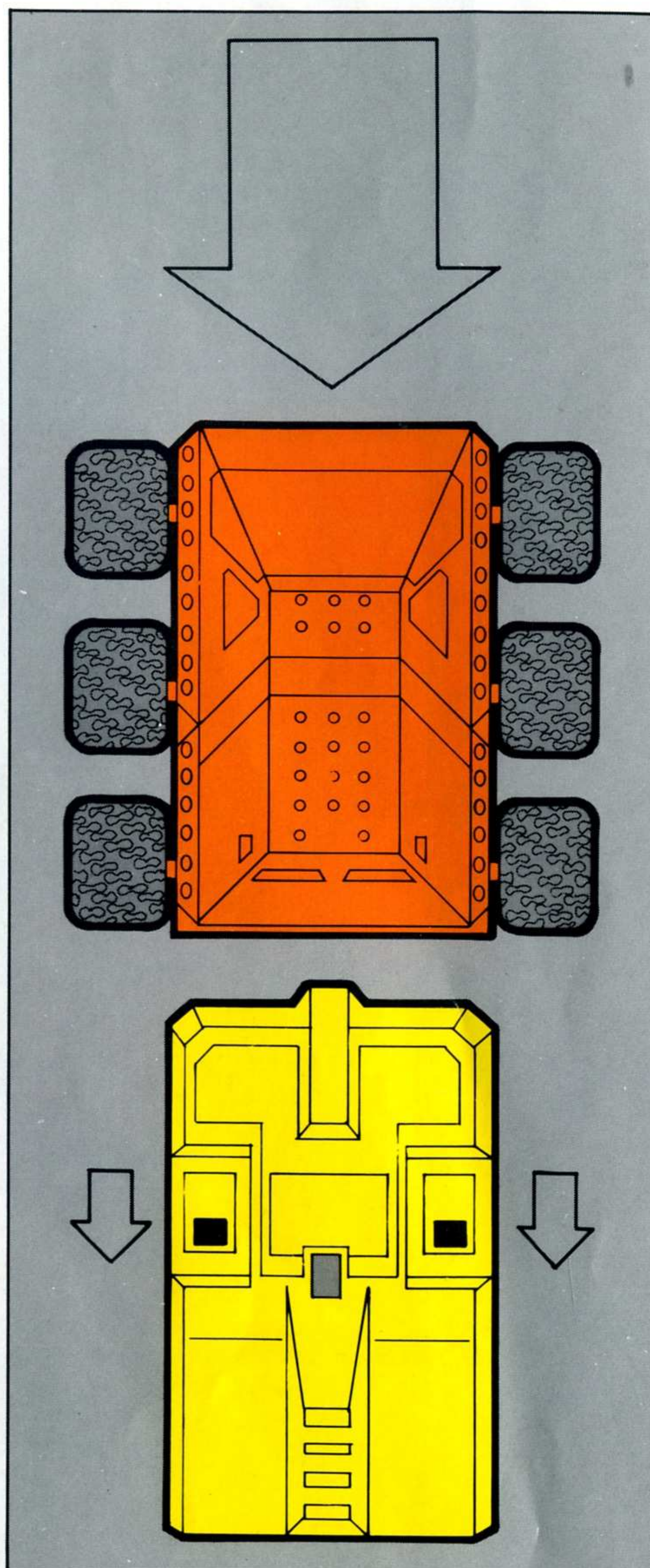

## ONE SWITCH IN "FORWARD," ONE SWITCH IN "OFF"

Model turns slowly in the opposite direction of the "forward" switch.

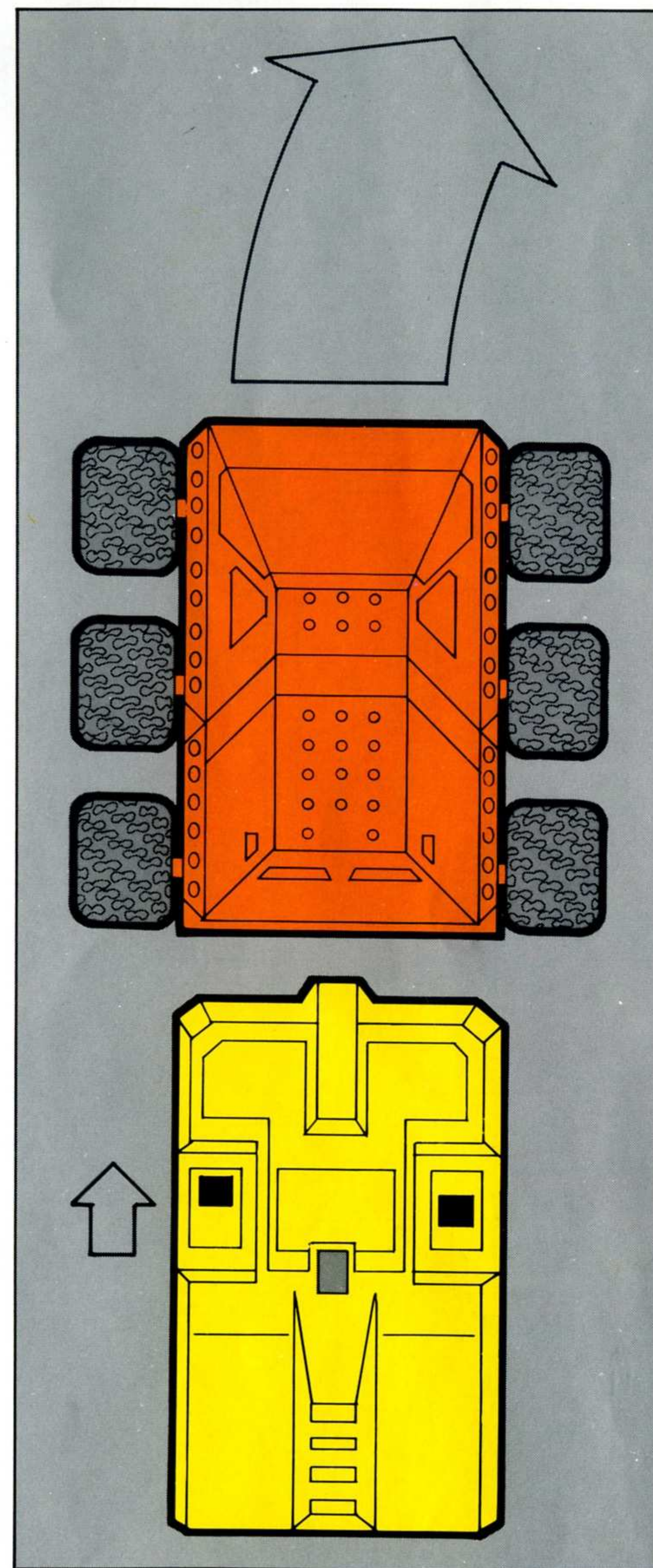

## ONE SWITCH IN "FORWARD," ONE IN "REVERSE"

Model turns sharply in the opposite direction of the "forward" switch.

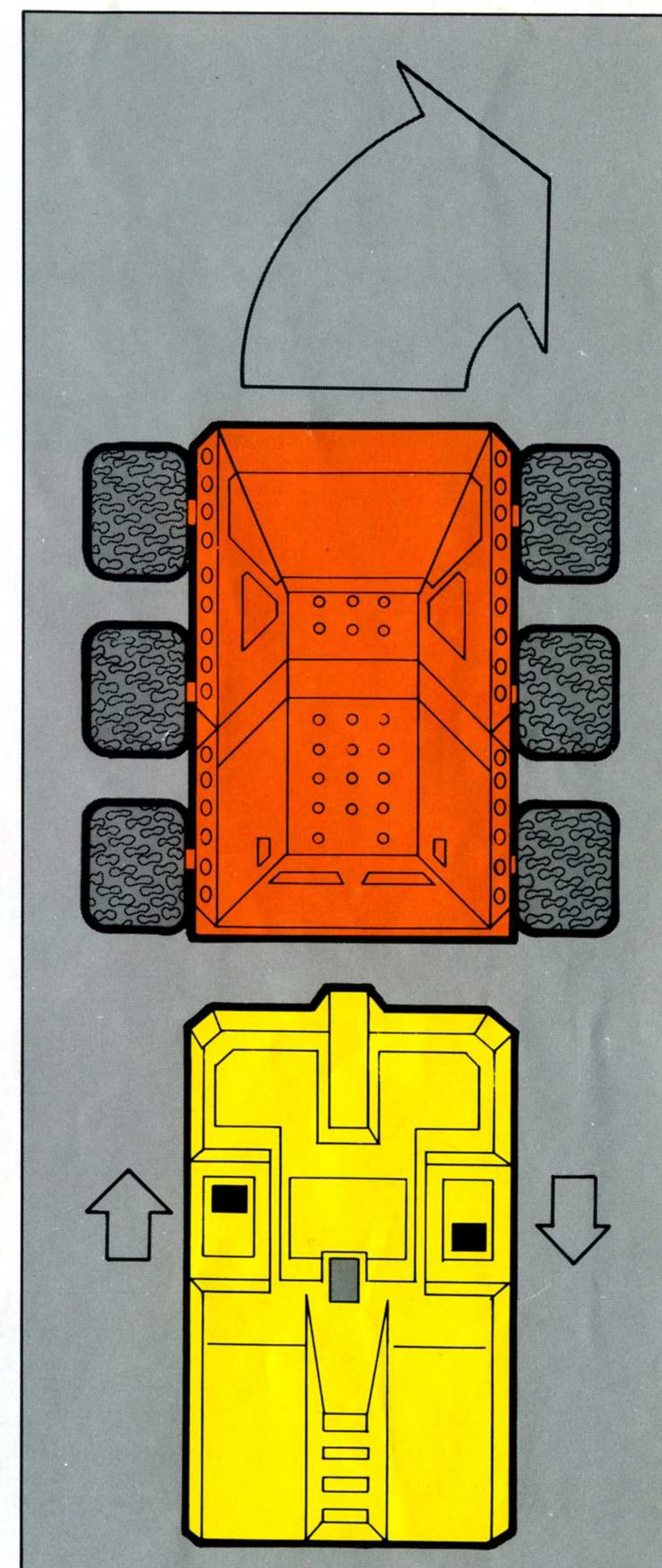

**NOTE:**  
Your models will move best on smooth floors. Running large models on carpet may drain batteries.

If your model won't move:  
(1) Lift it up so the wheels are off the table and try it again. If the wheels move, the batteries may be low or your model may be too heavy or unbalanced.

2) If the wheels still don't turn, pull the axles out of the motor and turn on again. If the motors work, check to see that you have the right axle support in place and that nothing is putting tension on the axle.

3) If nothing happens then, check all connections.  
4) If the connections are right and nothing happens, check the batteries. Are they in correctly? Are they worn out? We recommend alkaline batteries for longest use.



# CUSTOMIZE YOUR MODELS

Use the label sheets to decorate your models. Follow picture. Apply labels to body pieces by matching the numbered label to the numbered space.

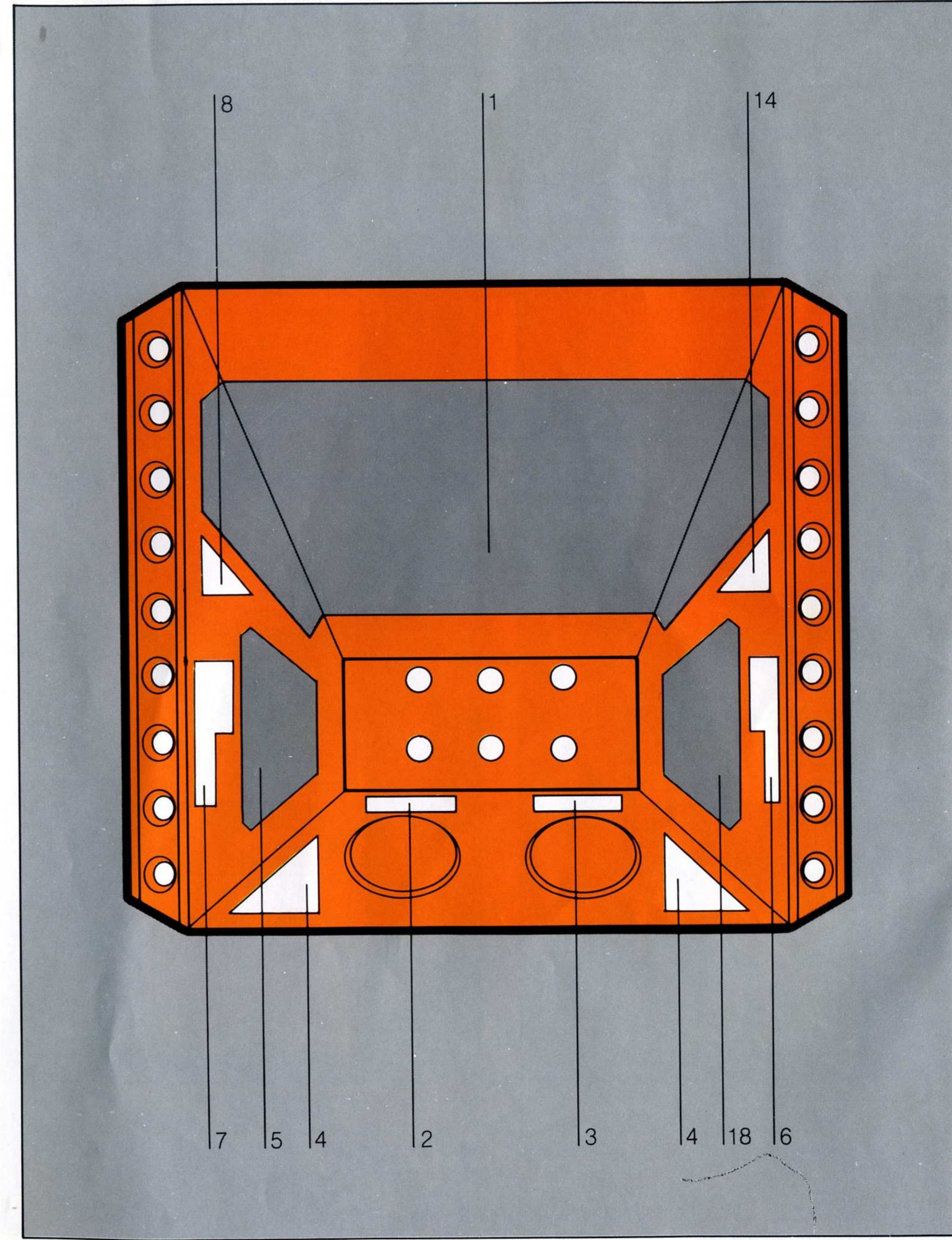
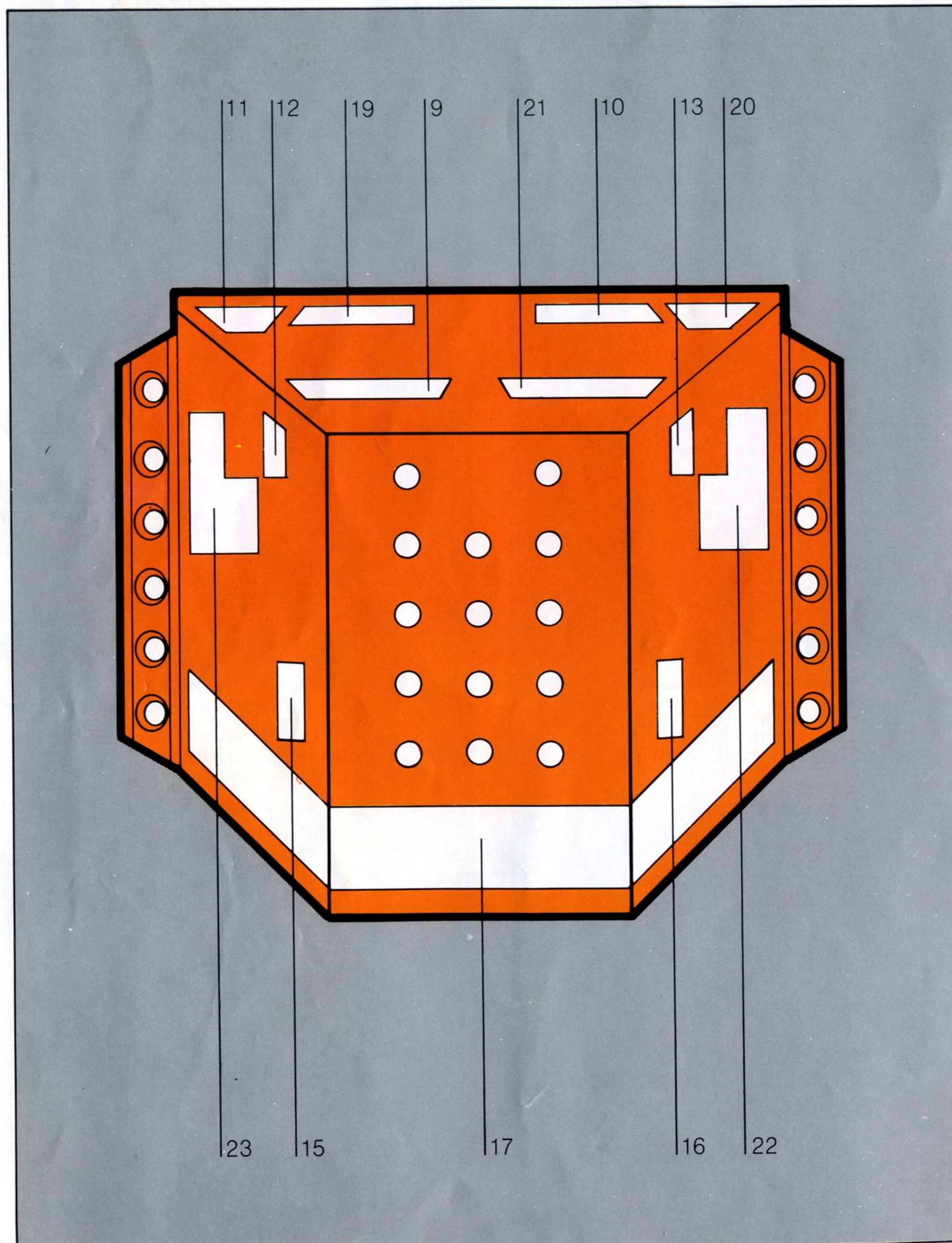



# DUMPTRUCK

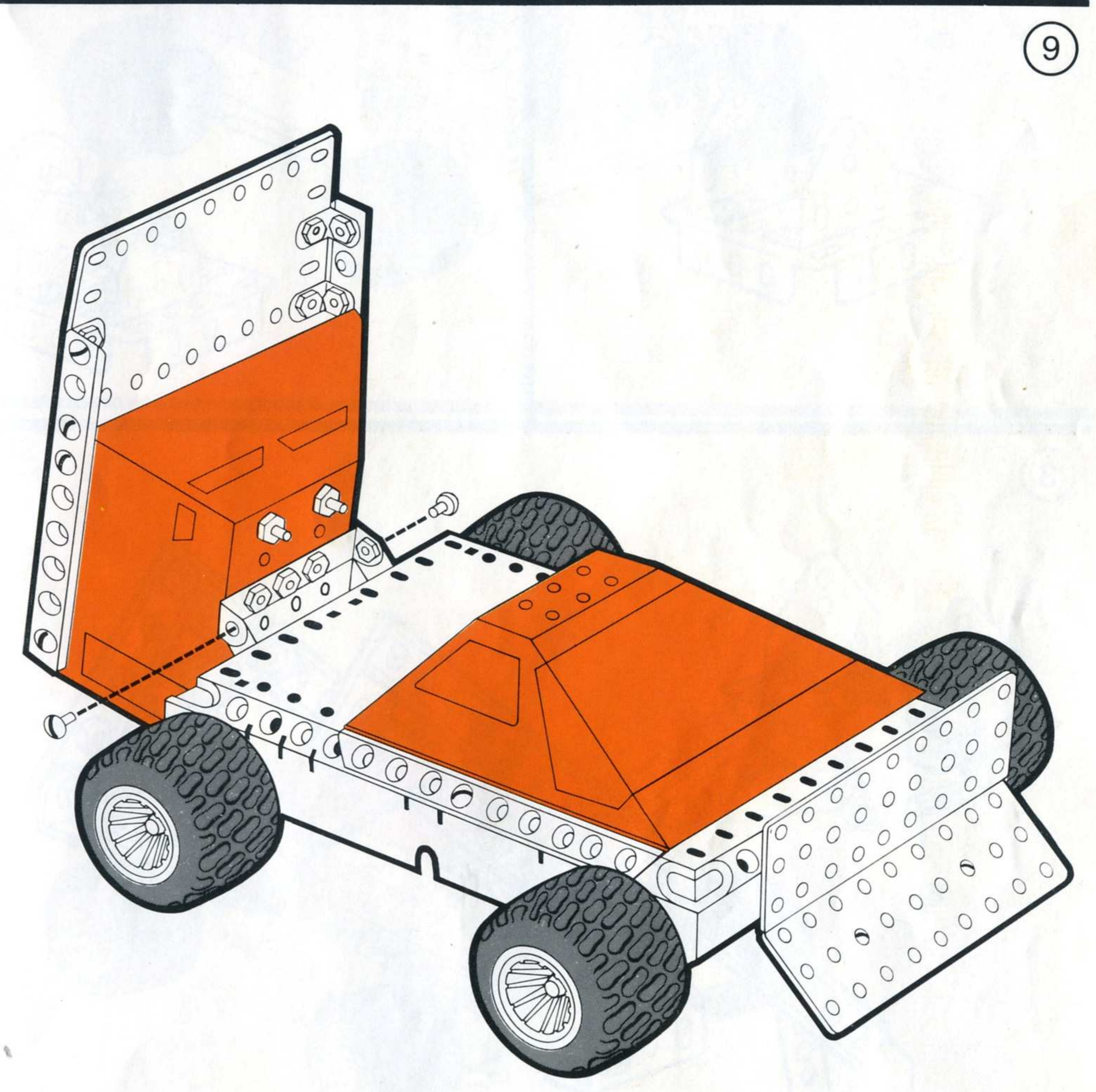
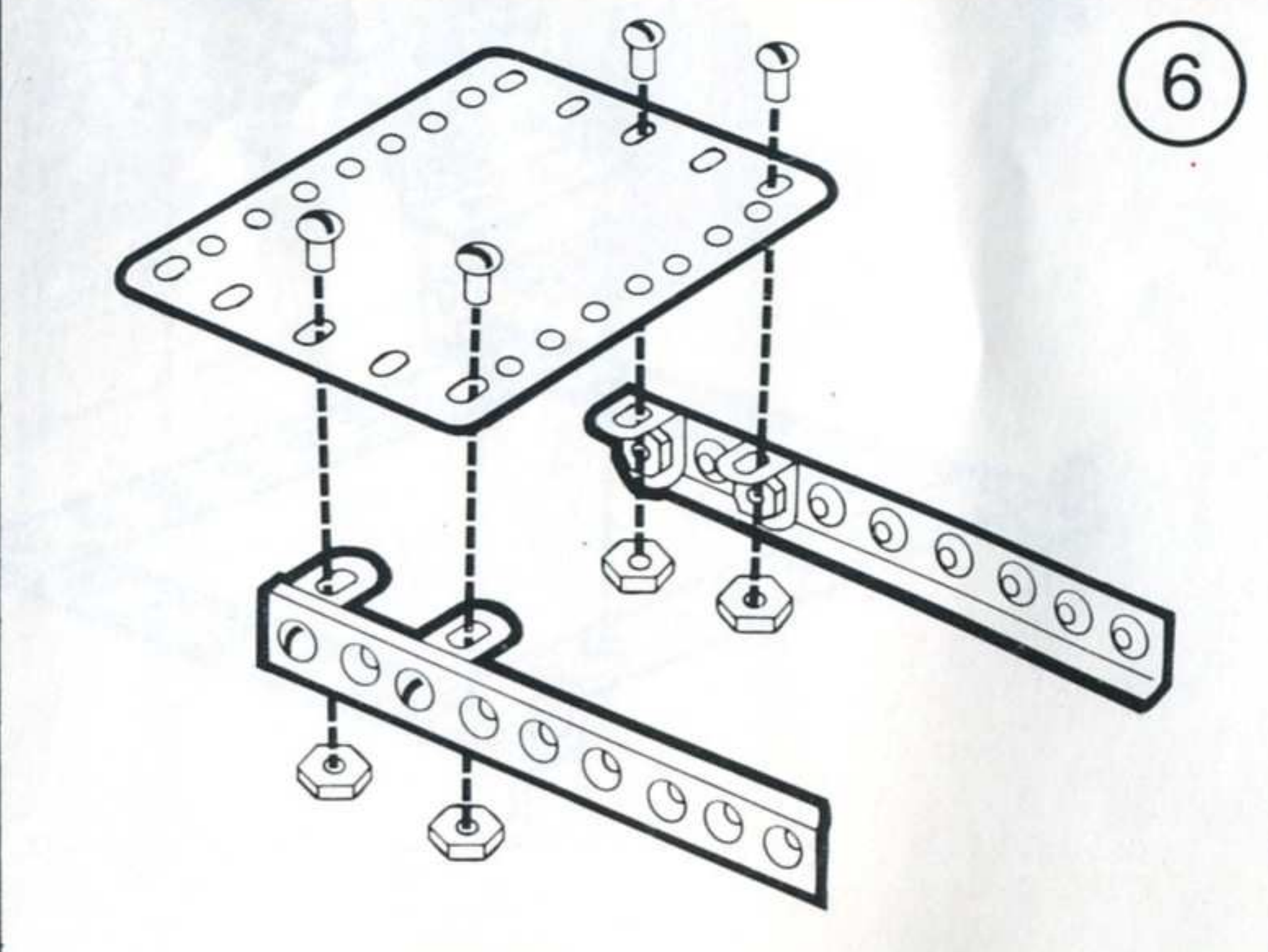
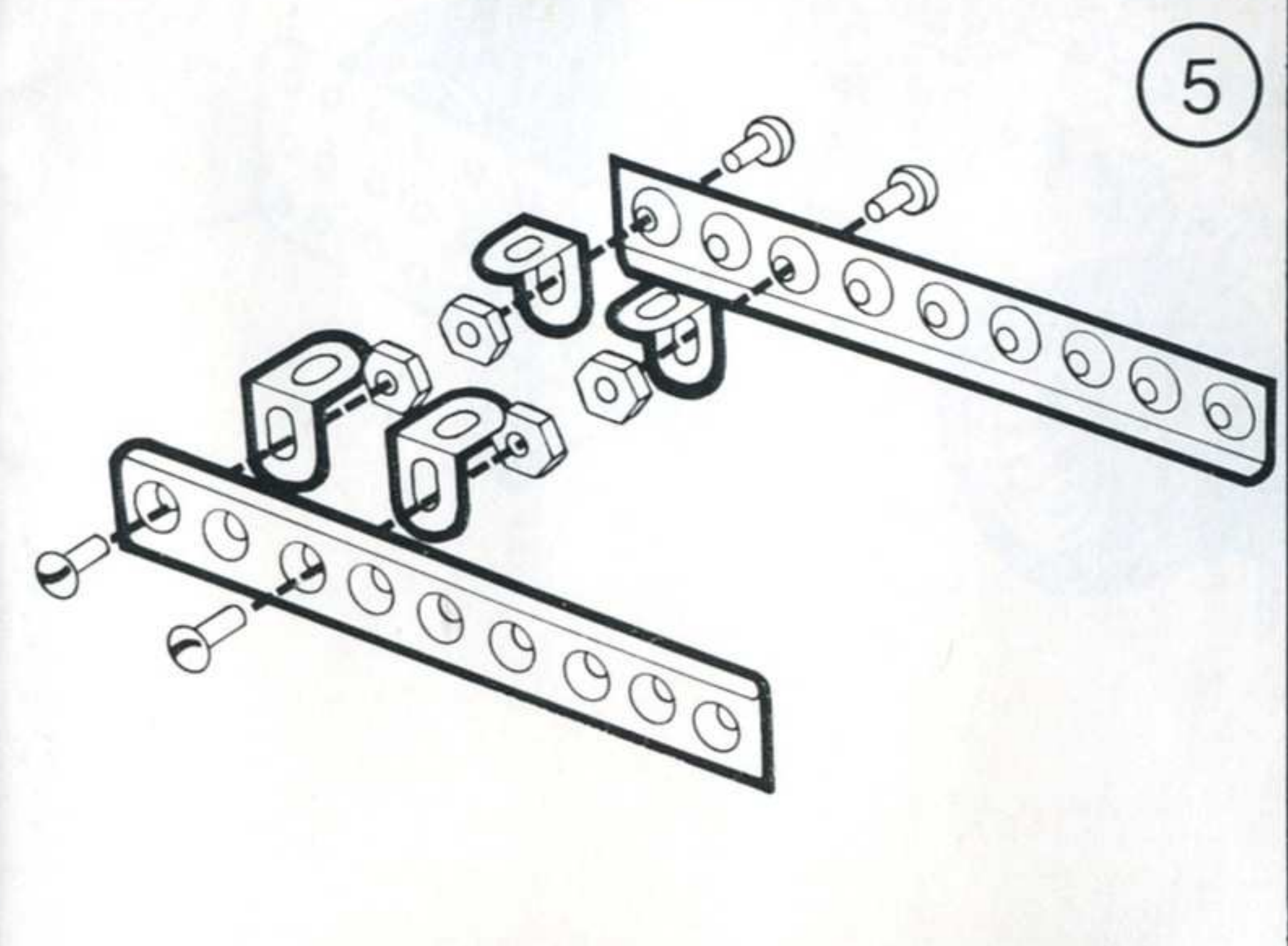
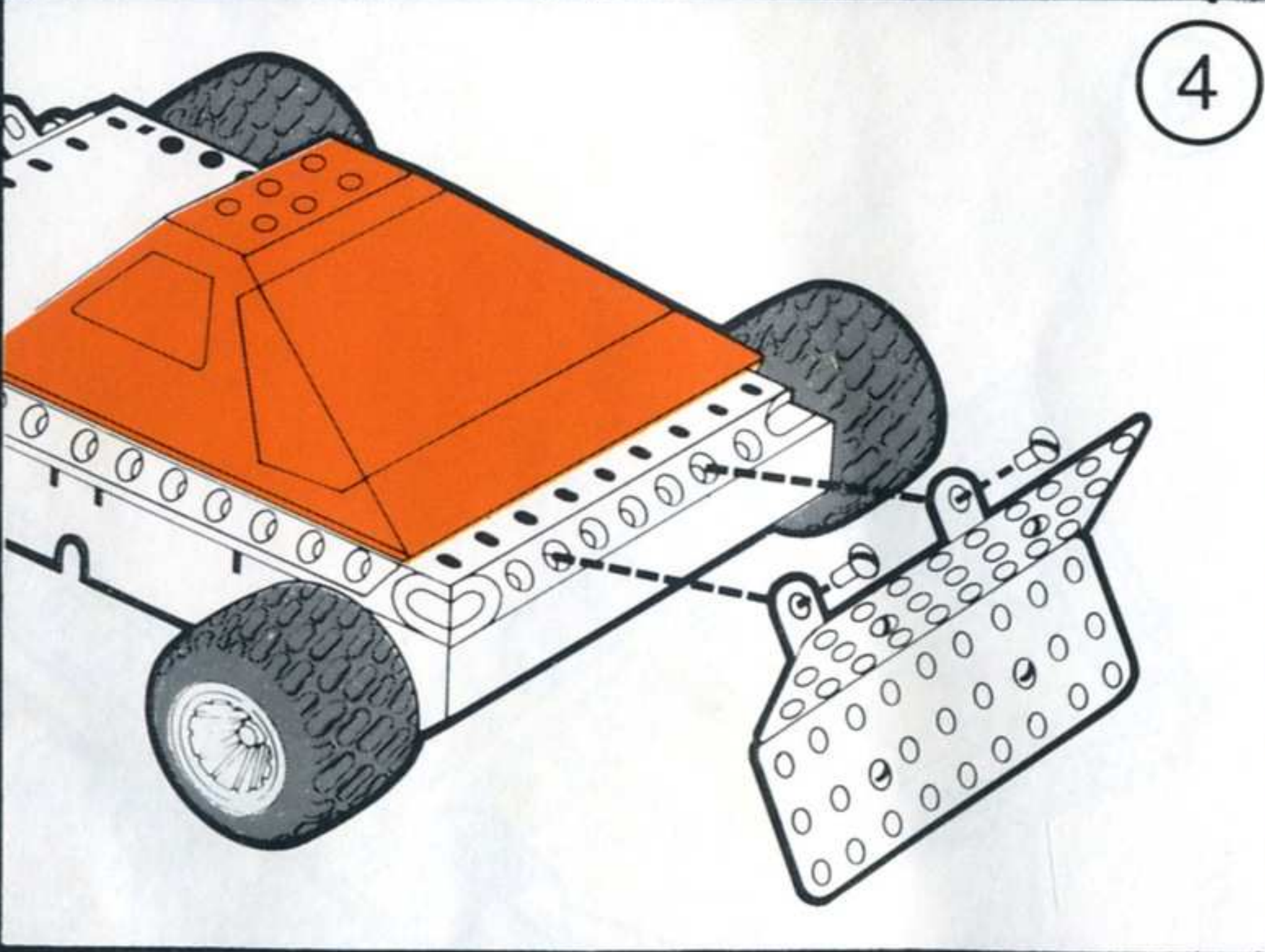
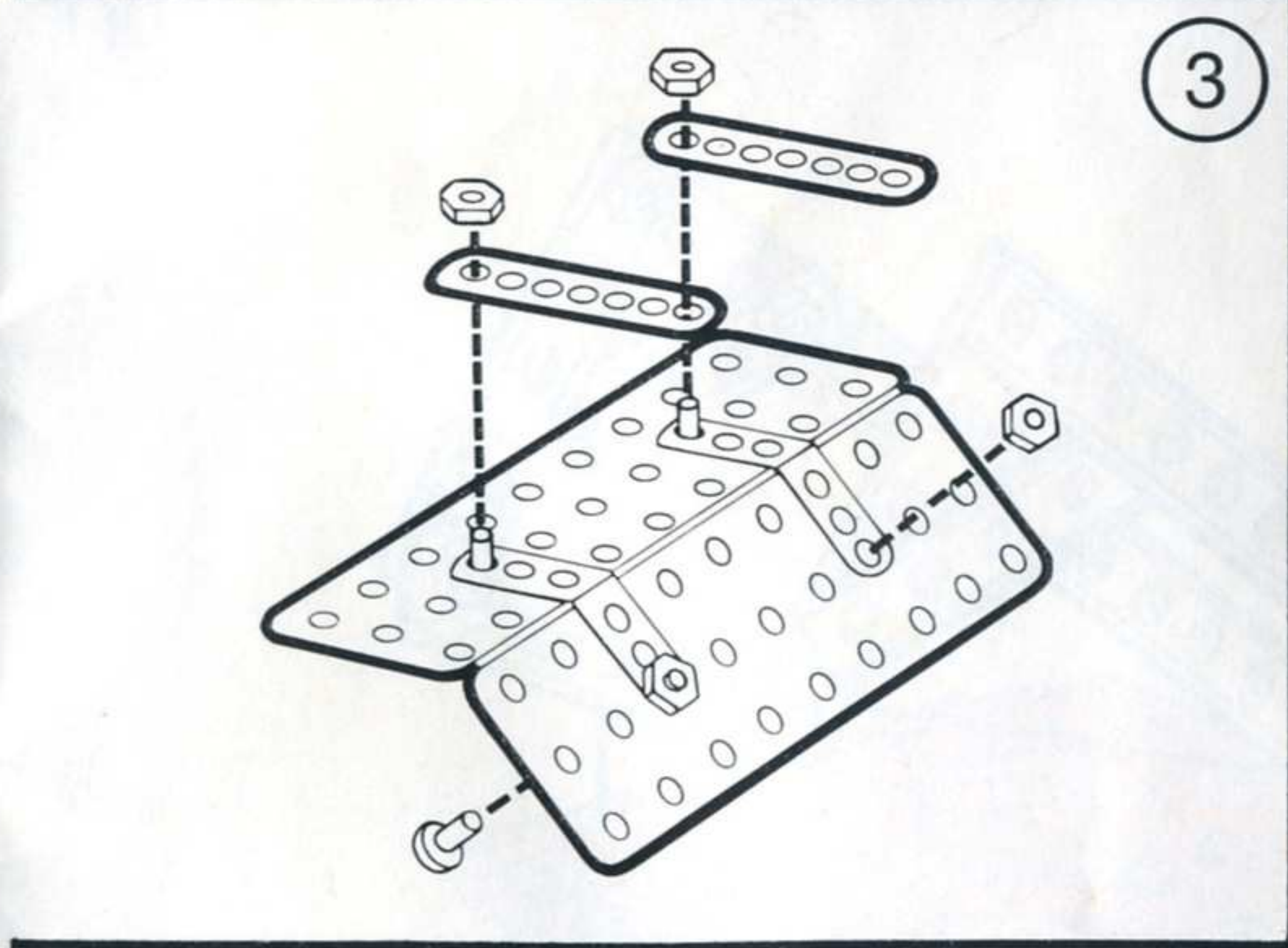
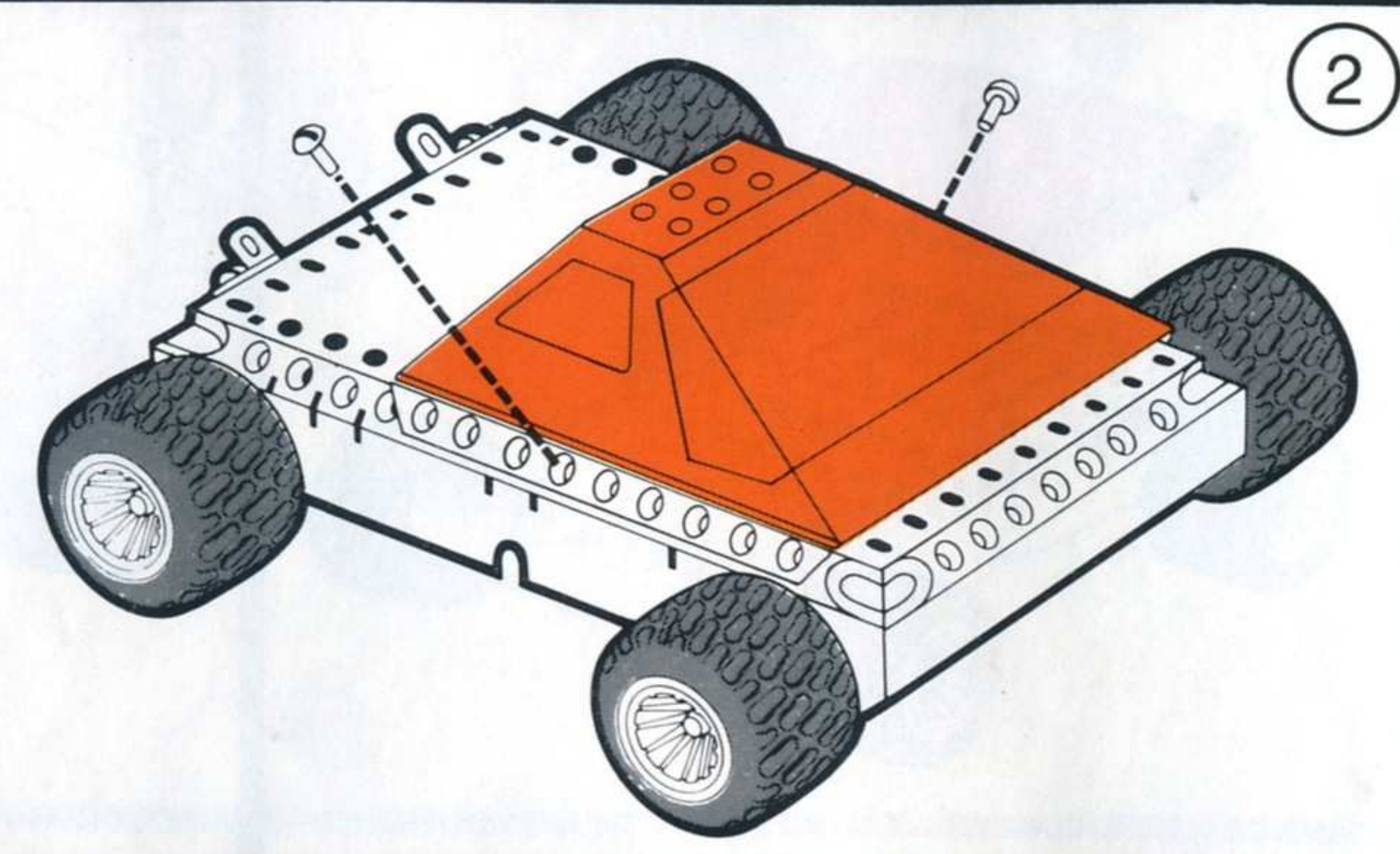
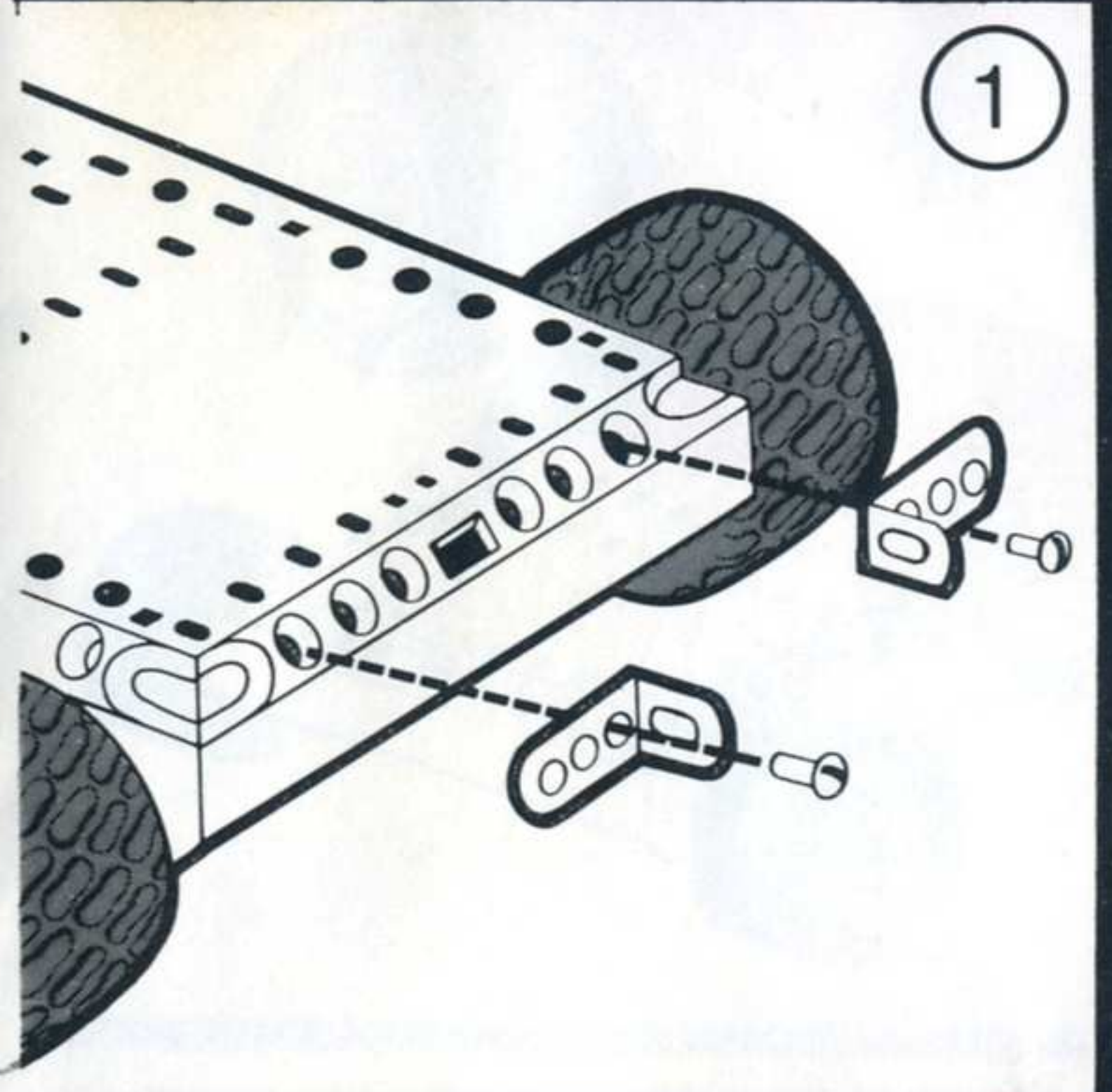
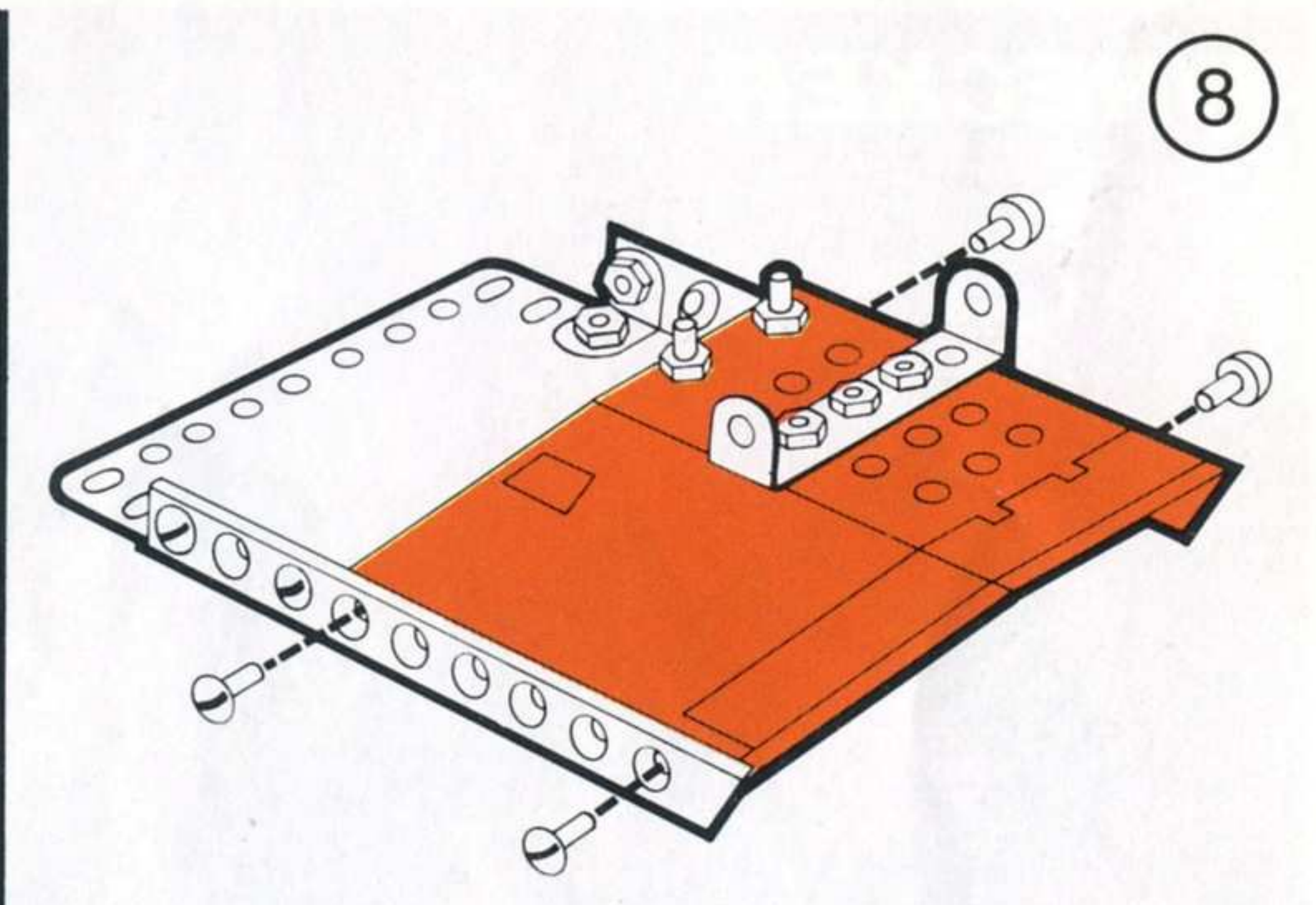
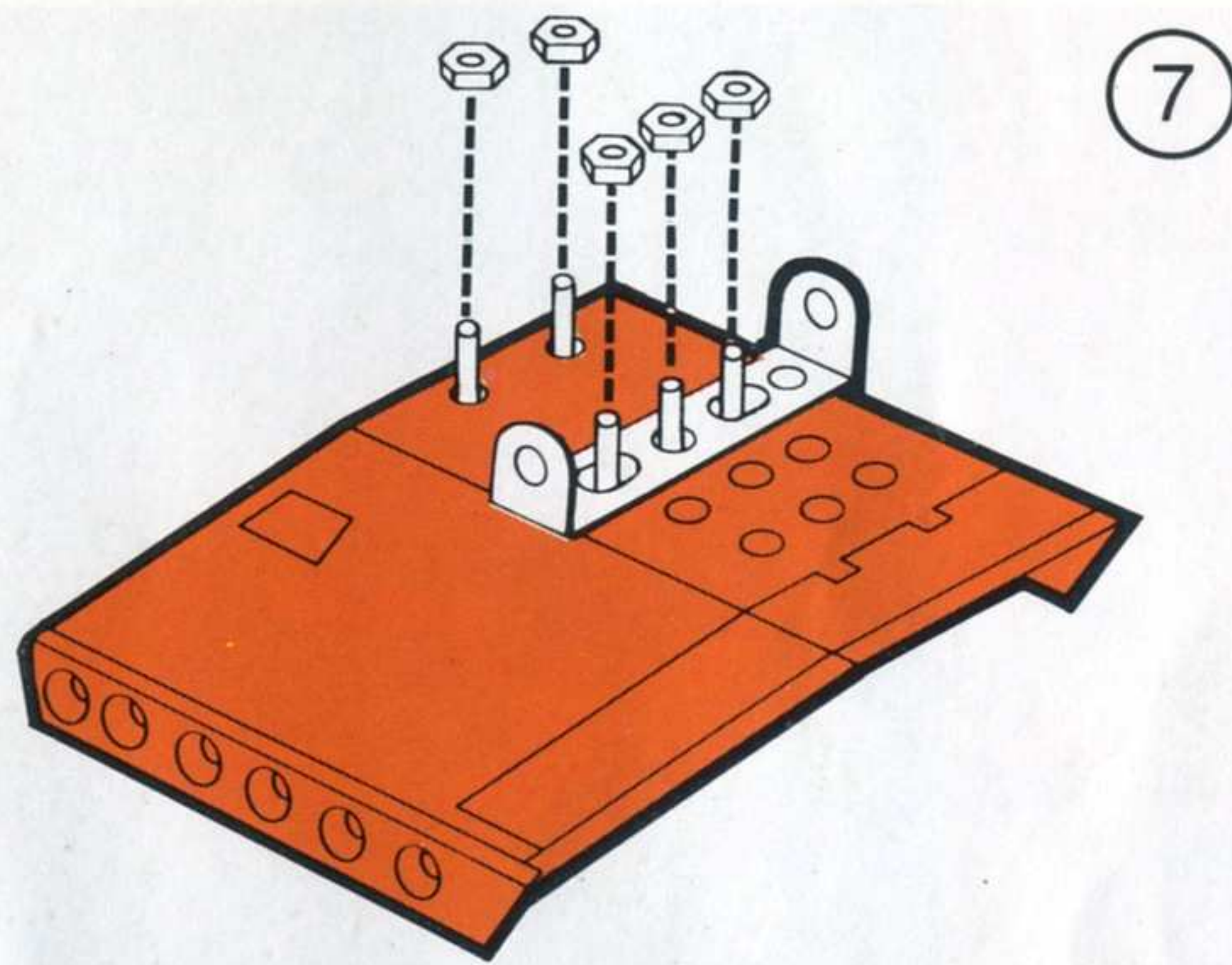
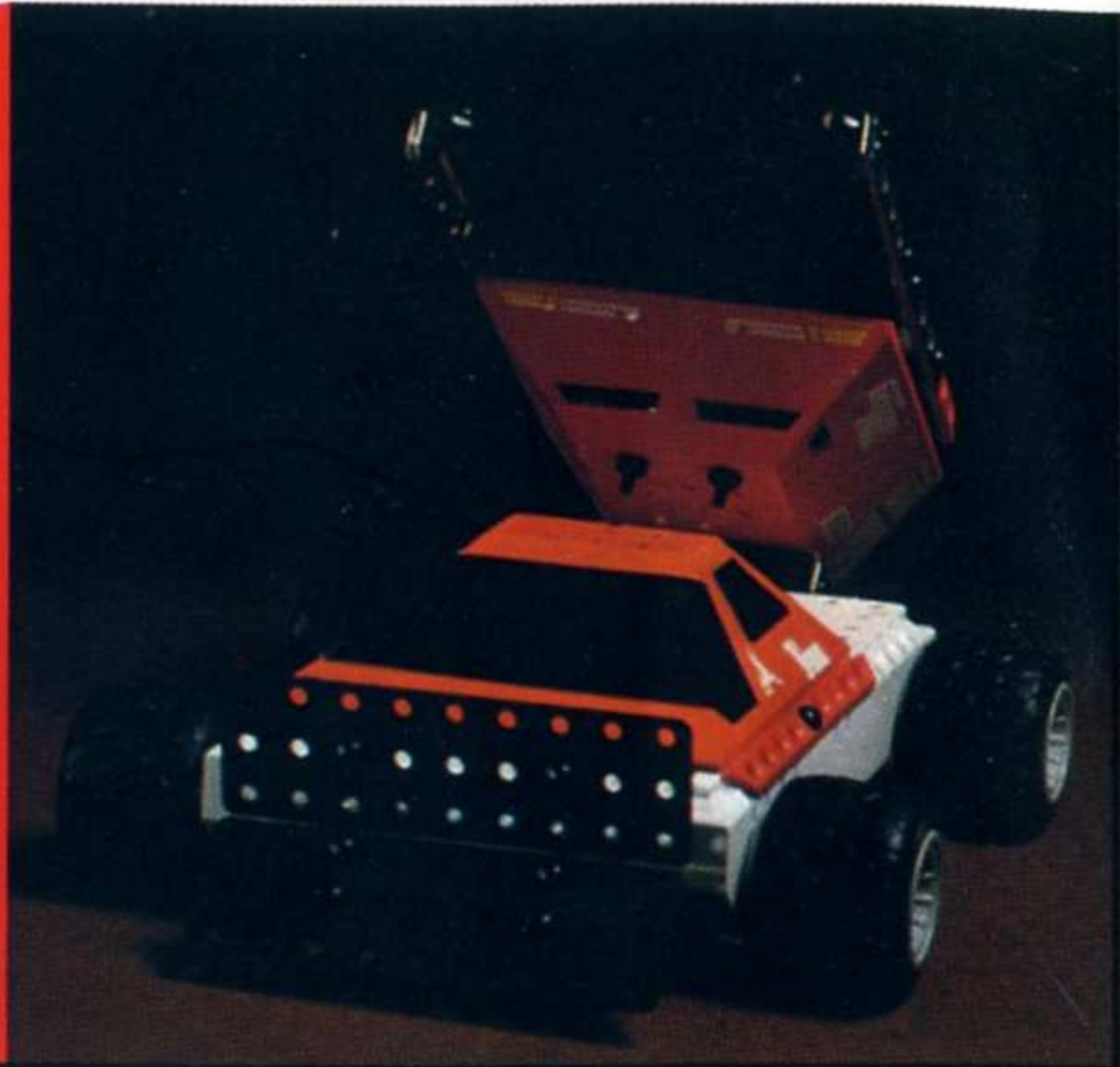



# WRECKER



1

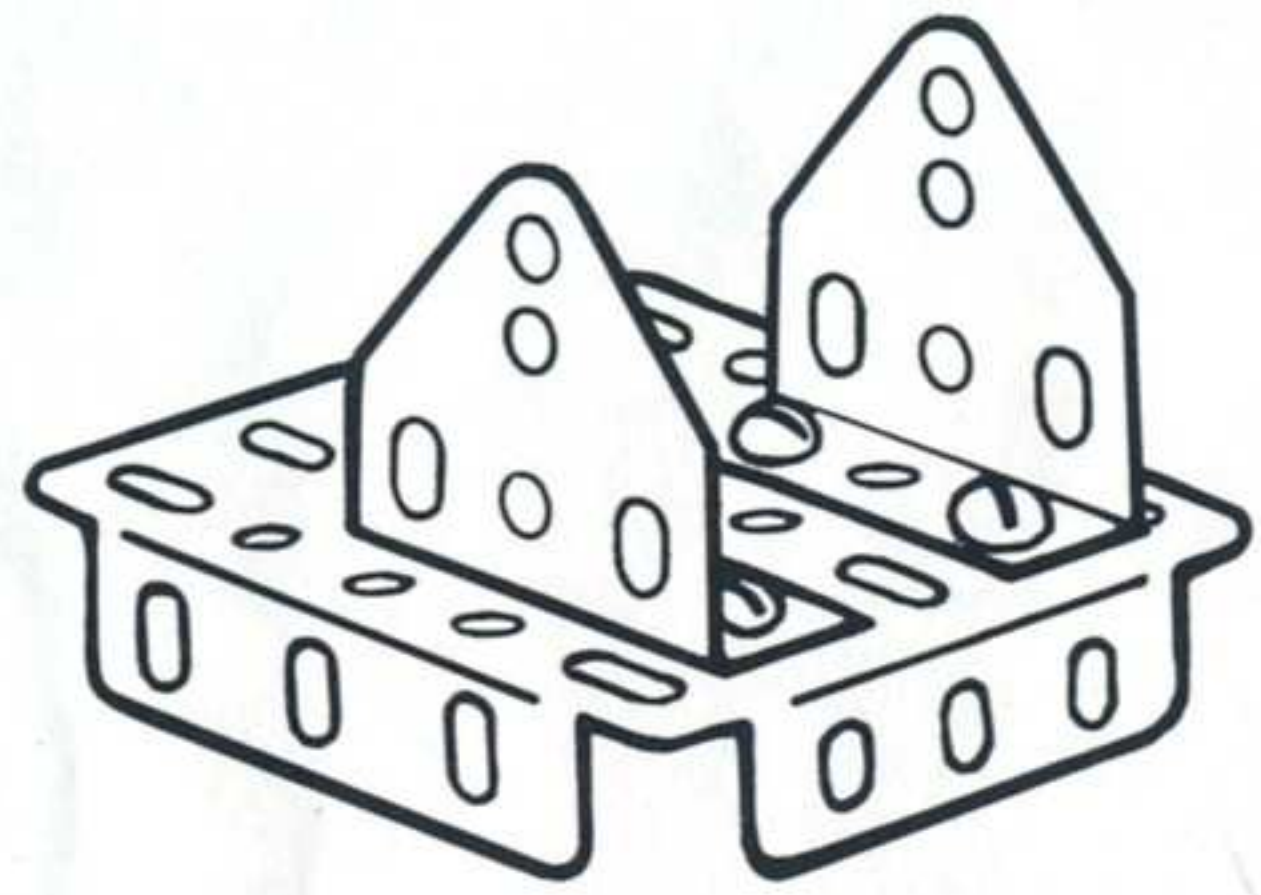

2

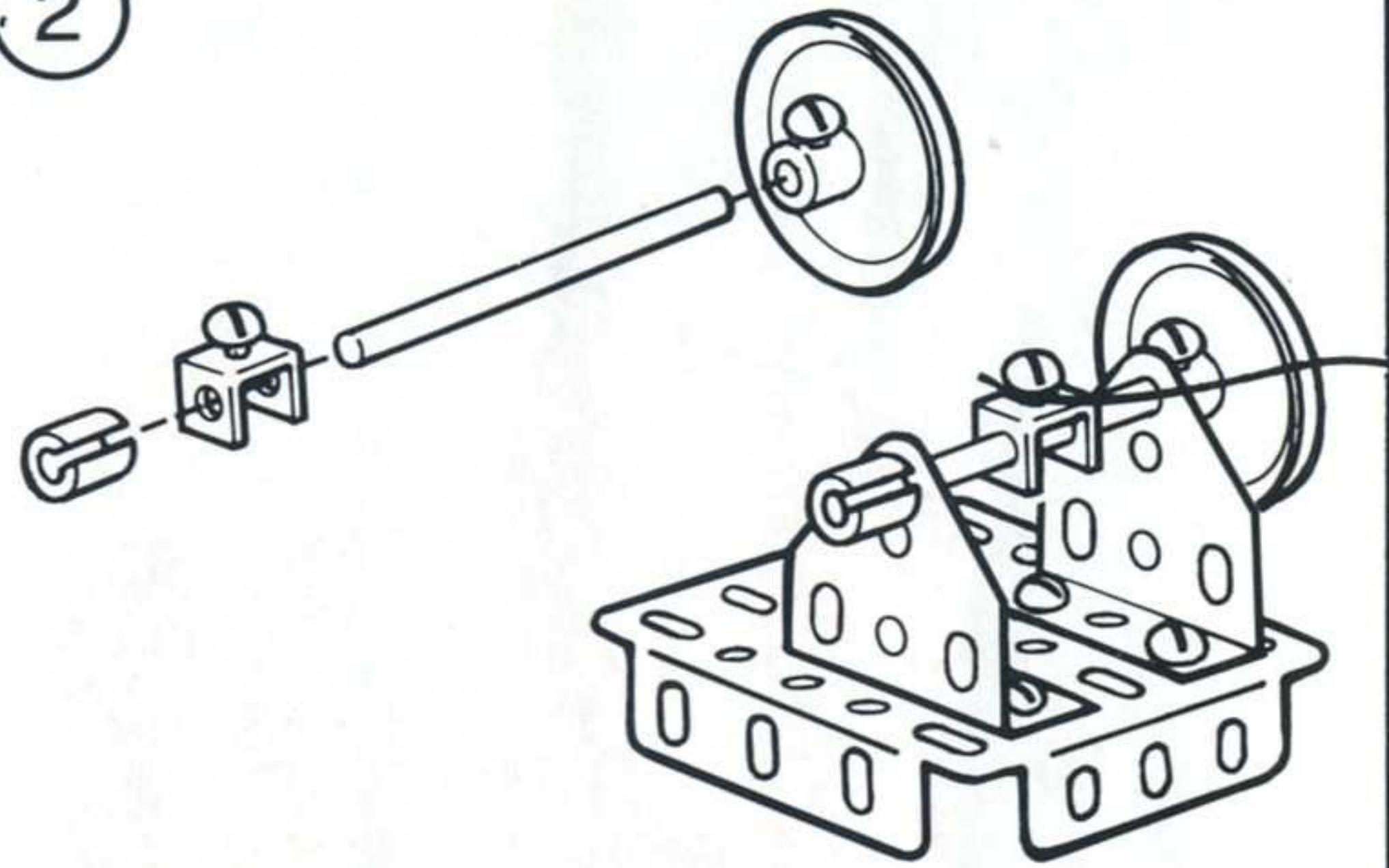

4

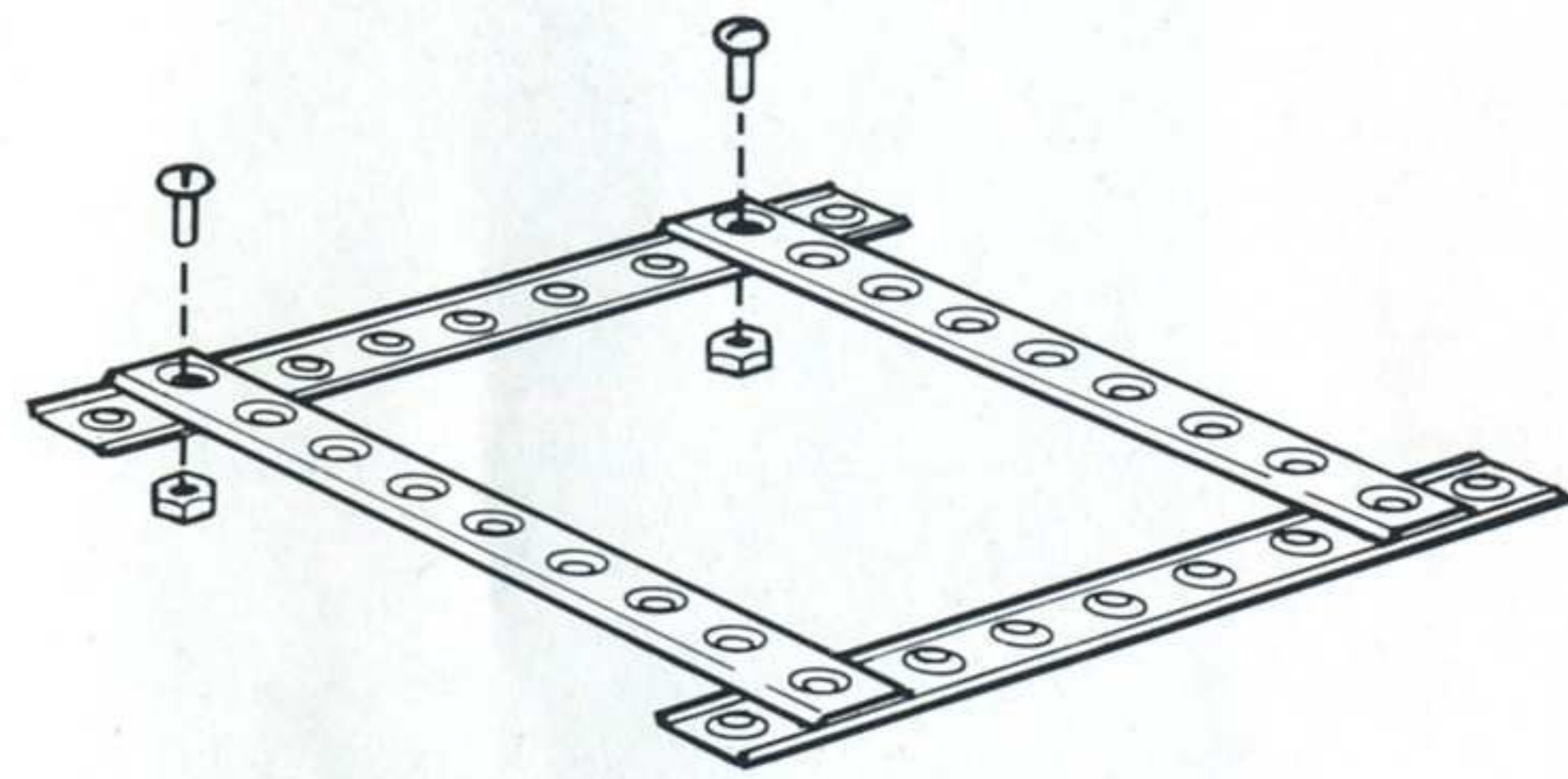

5

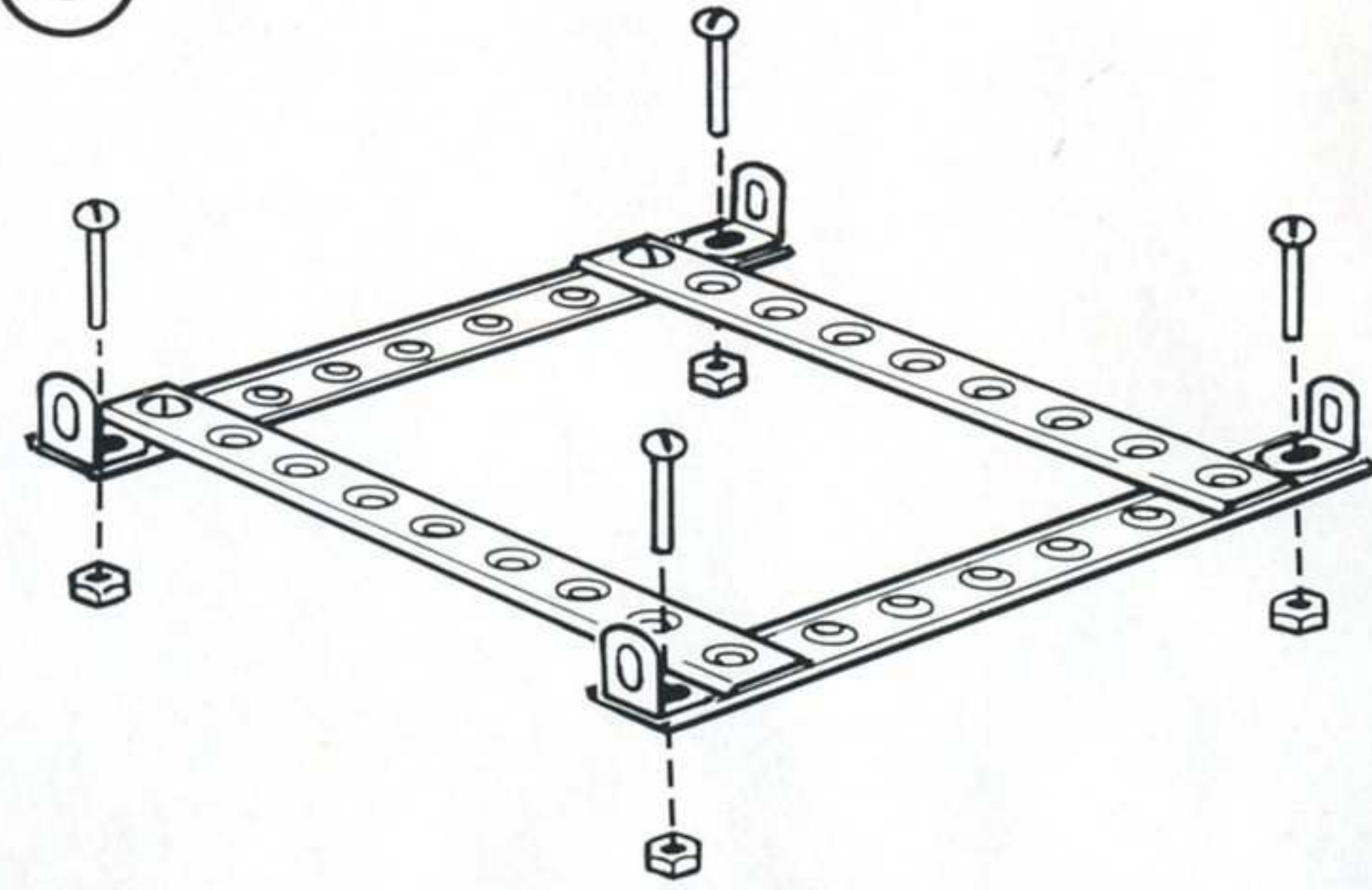

6

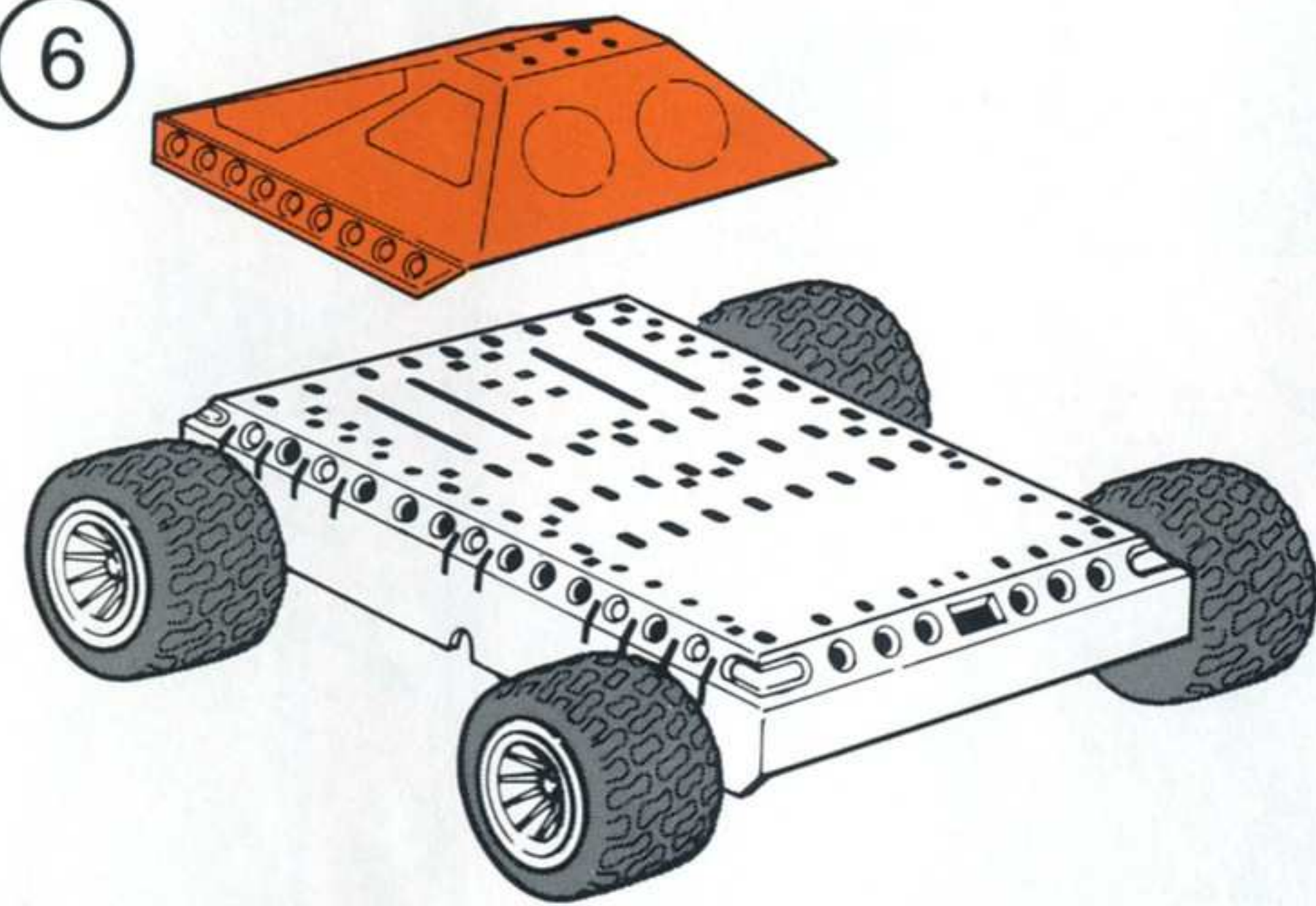

7

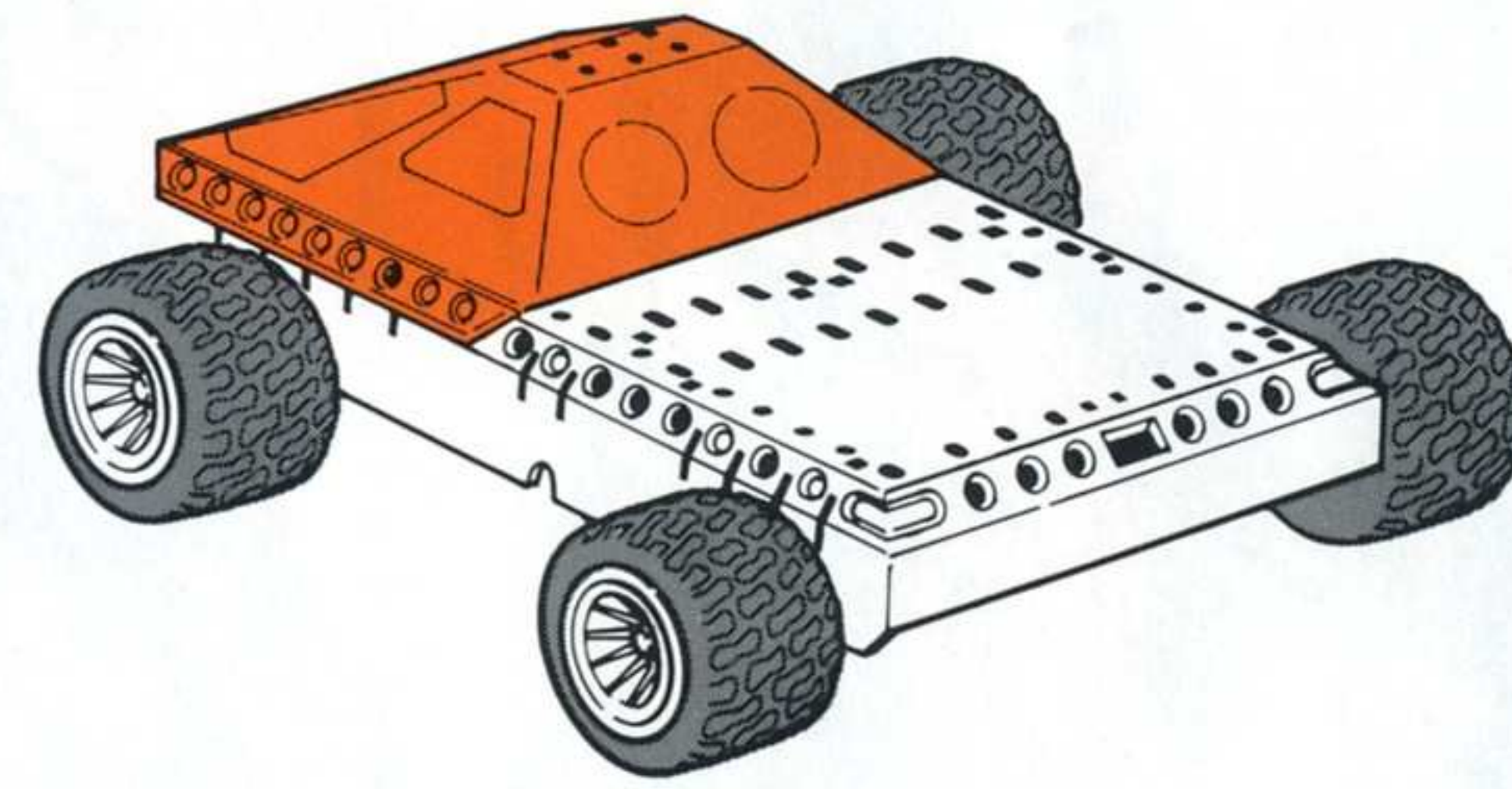

3

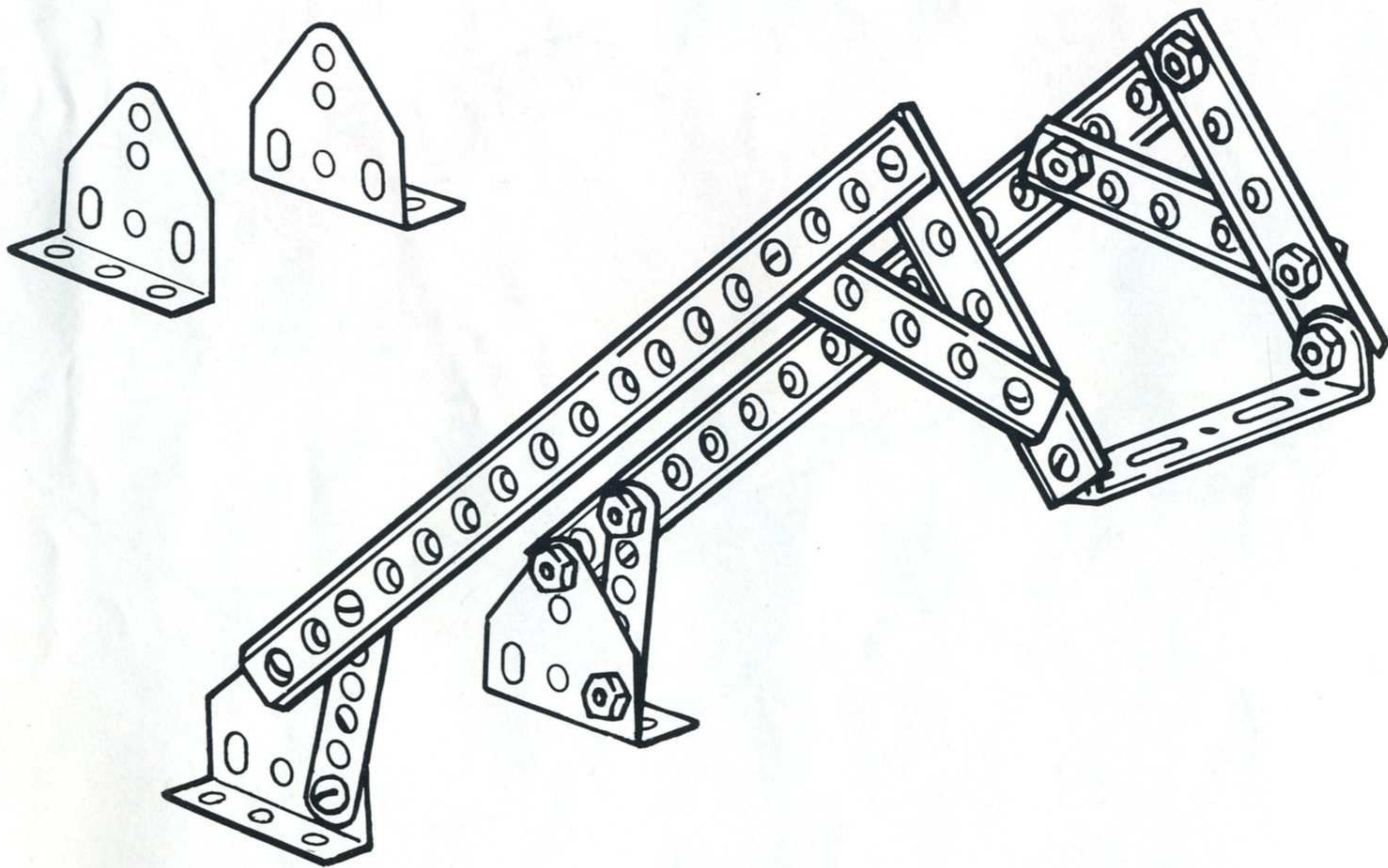

8

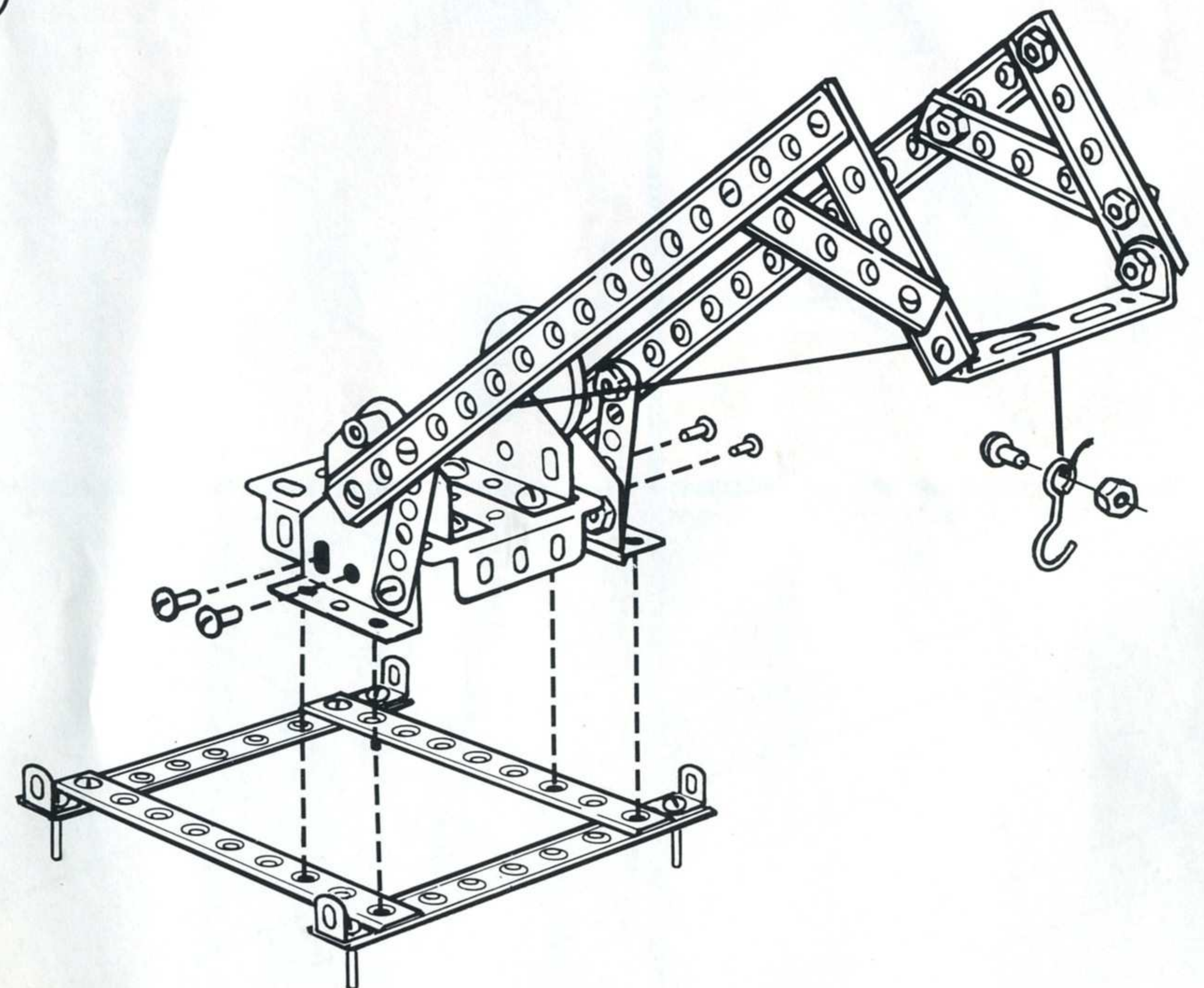



9

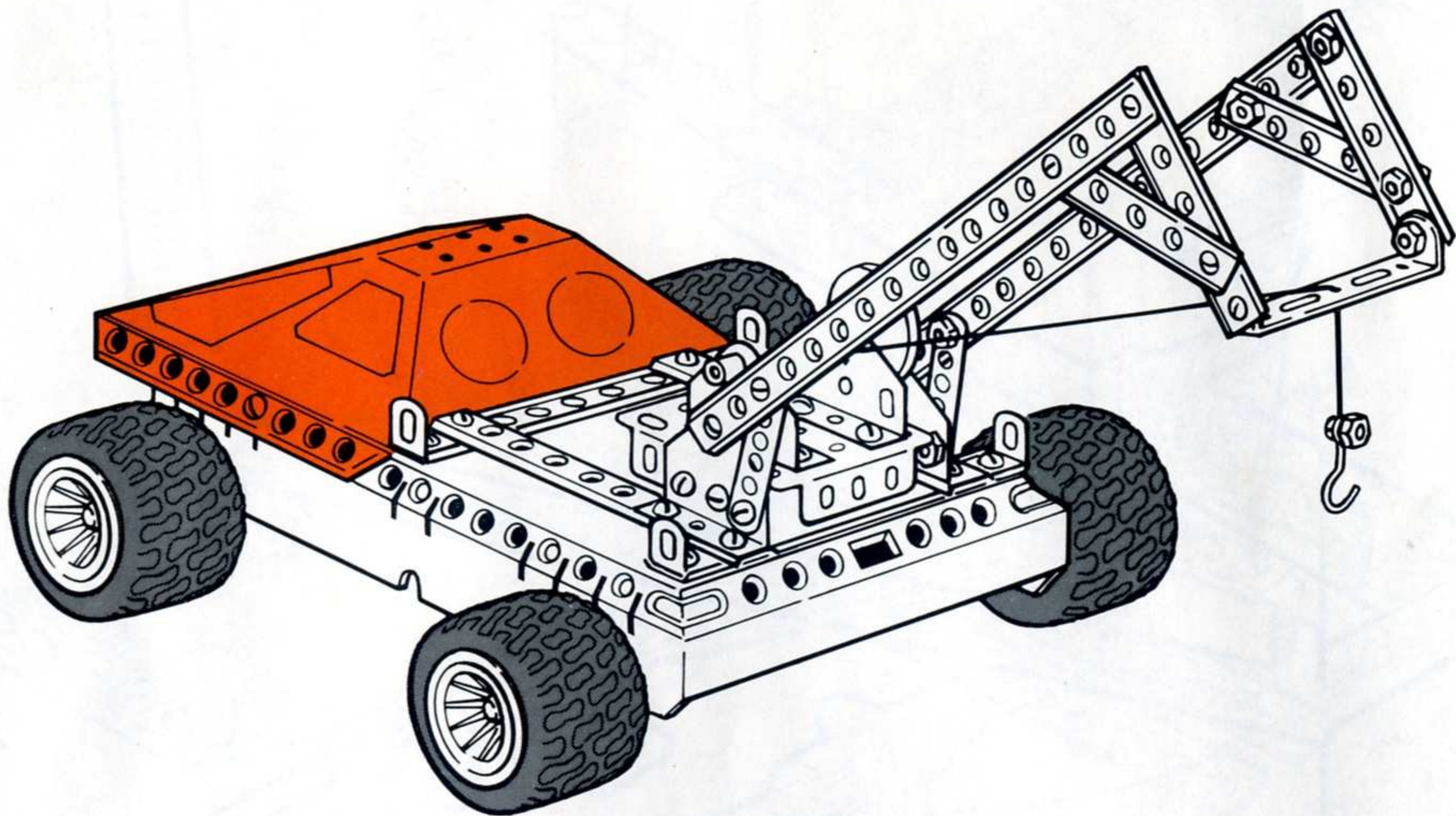

11

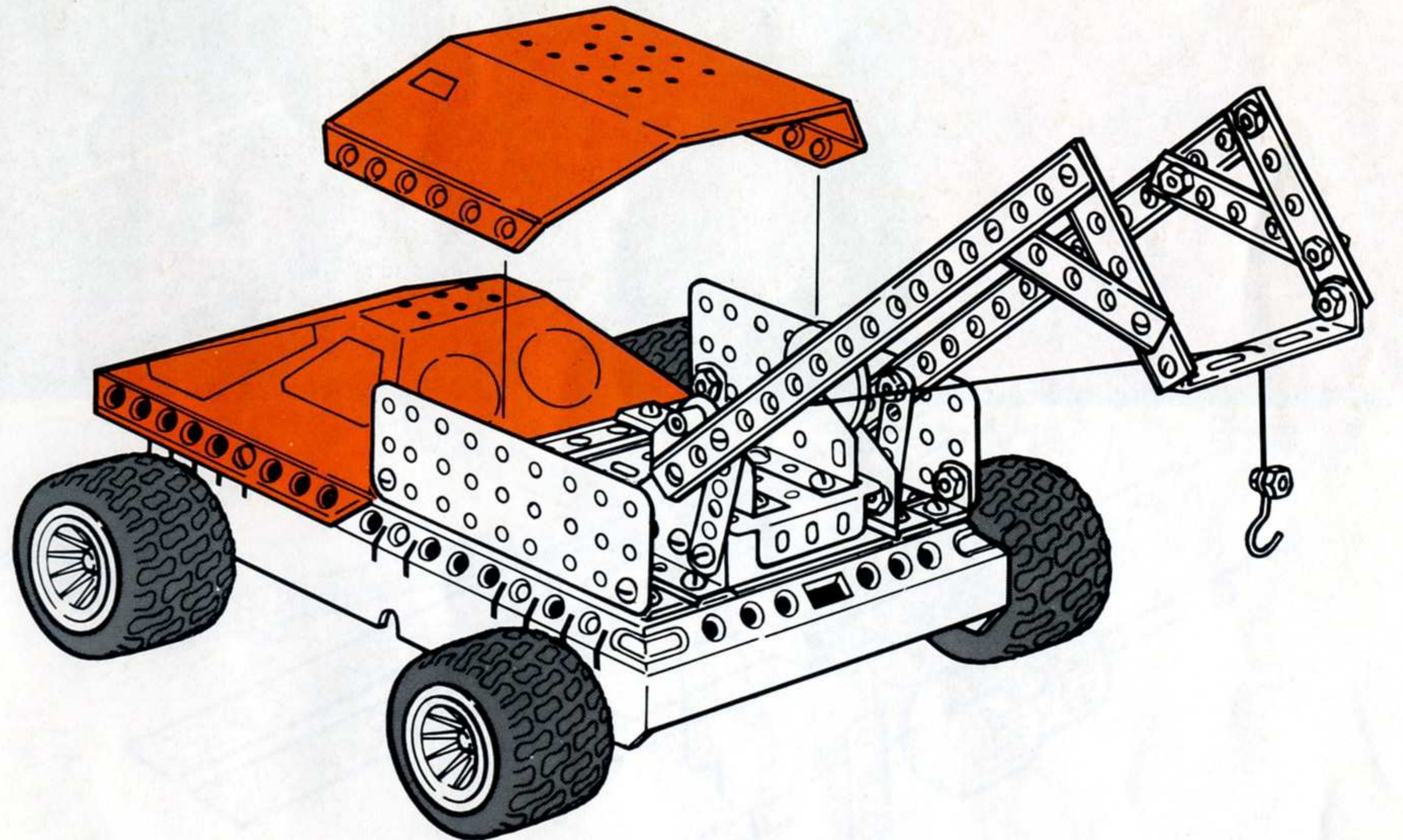

10

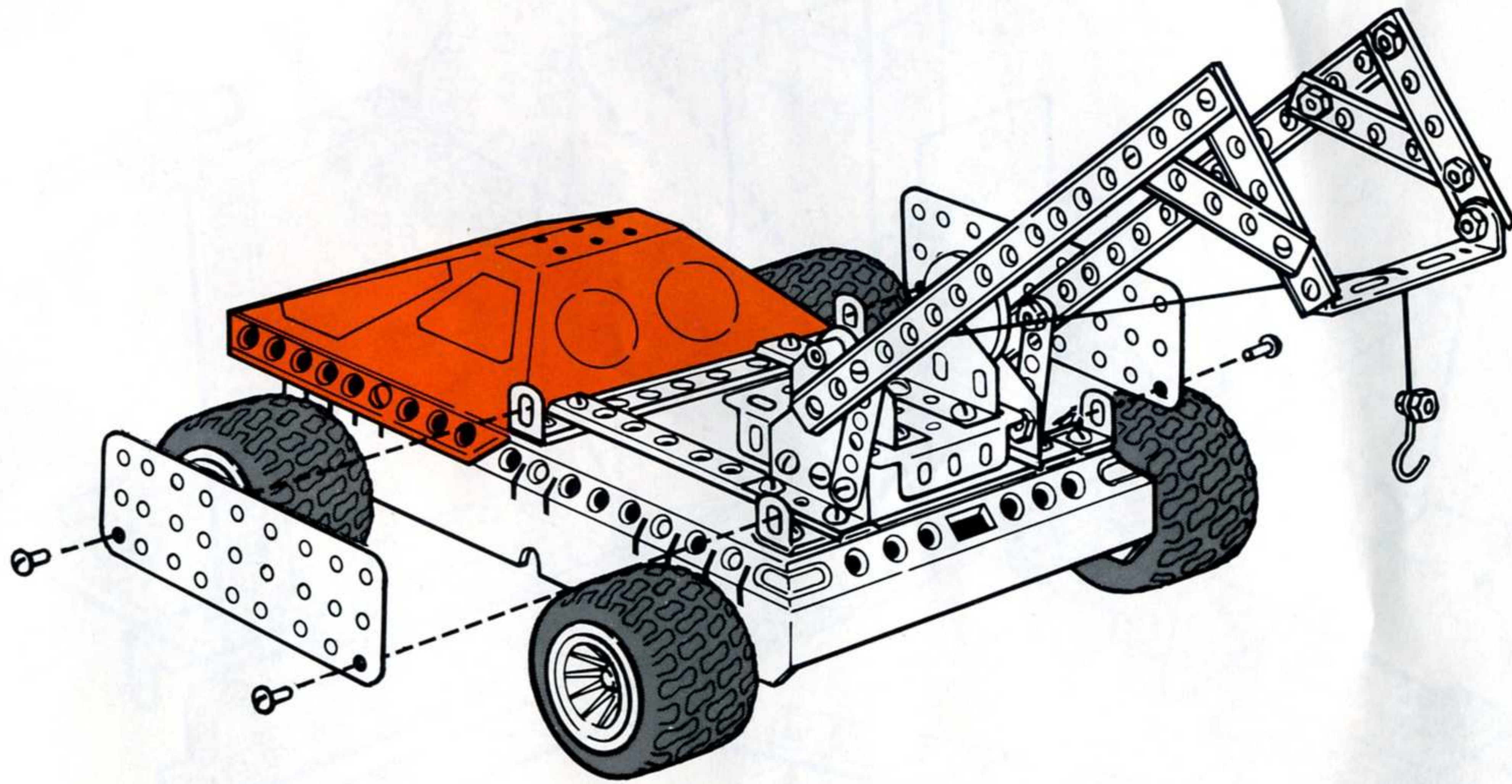

12

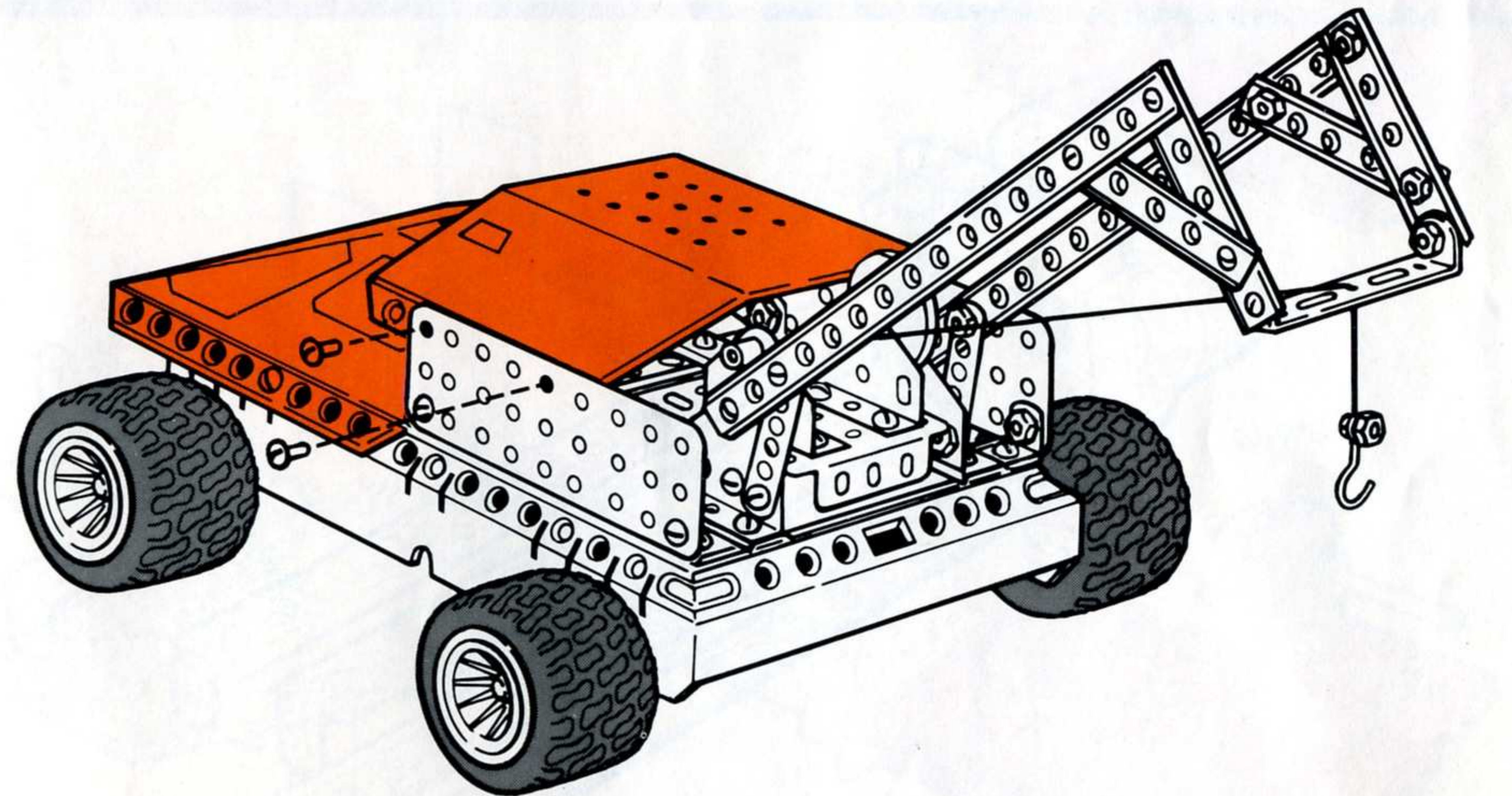



# ASTRO-SCOUT SHIP

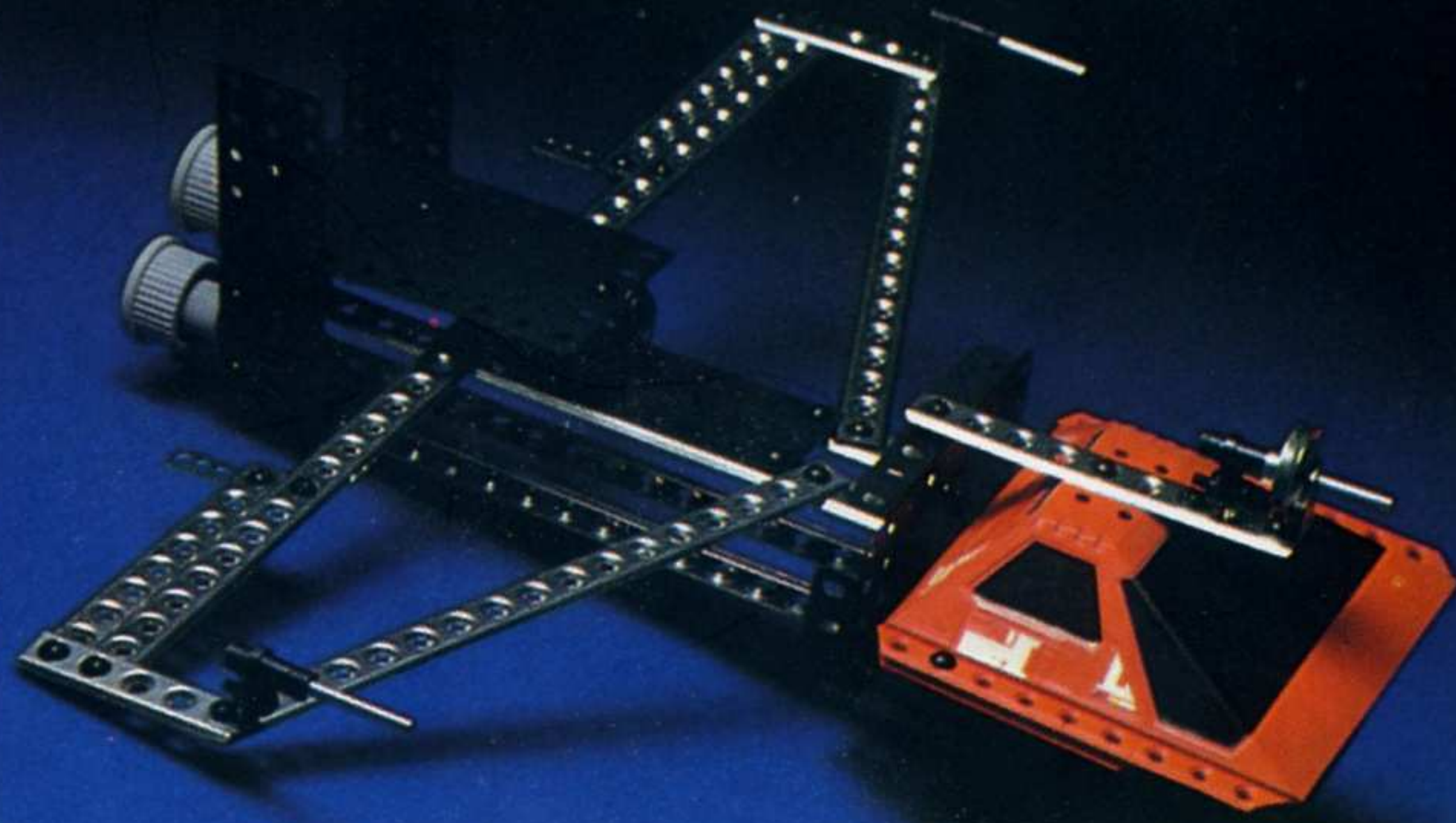

1

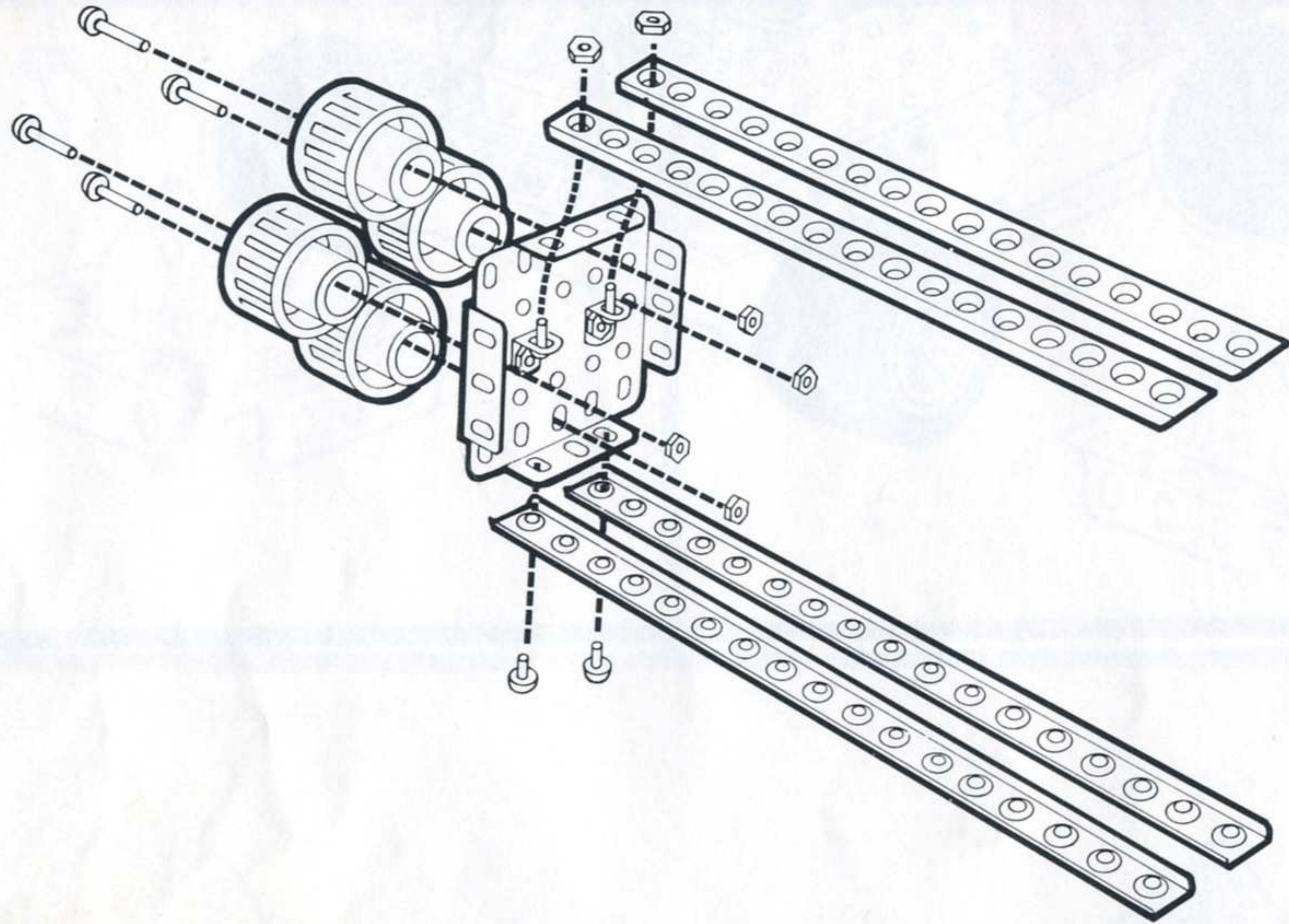

2

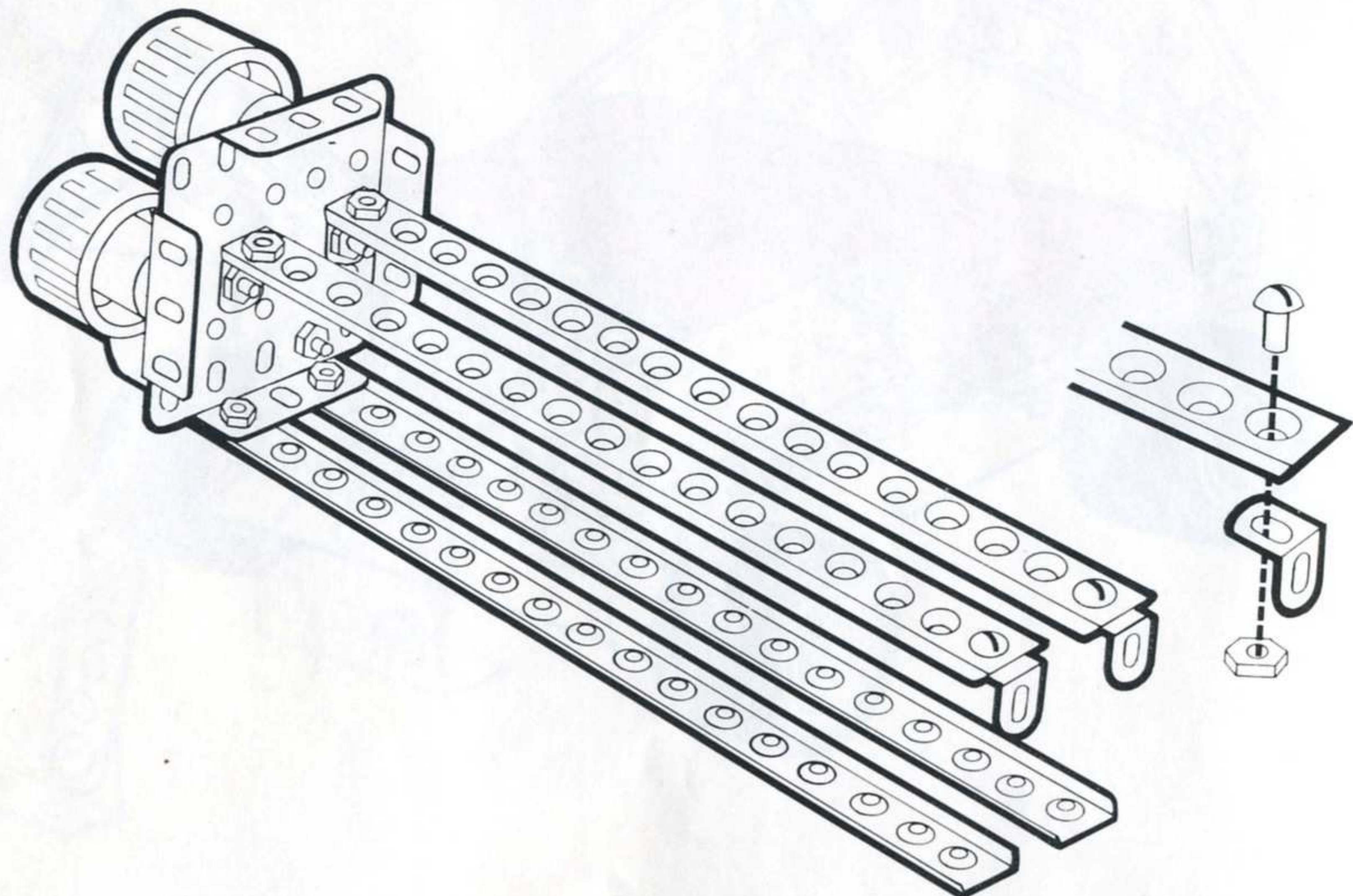

3

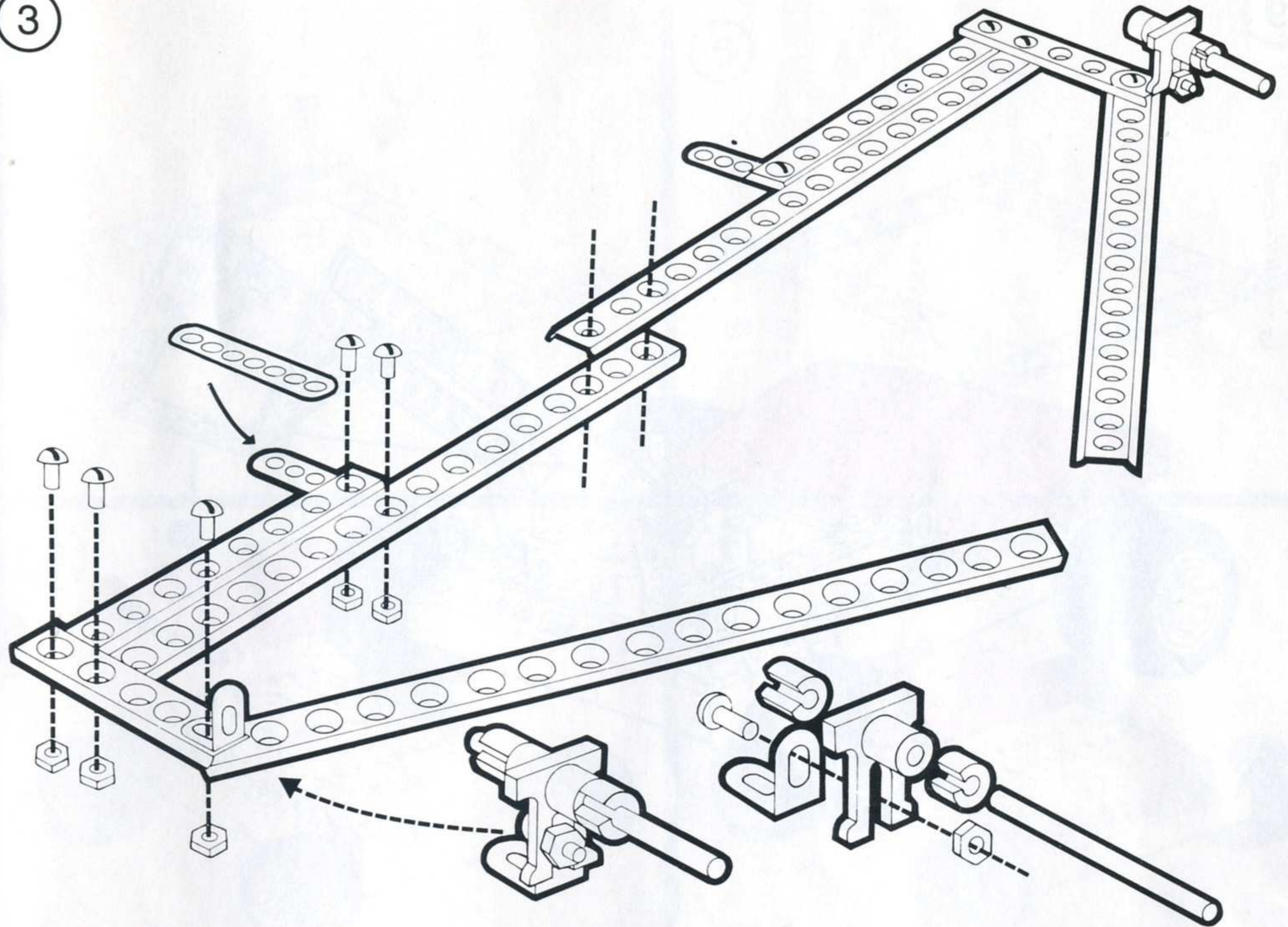

4

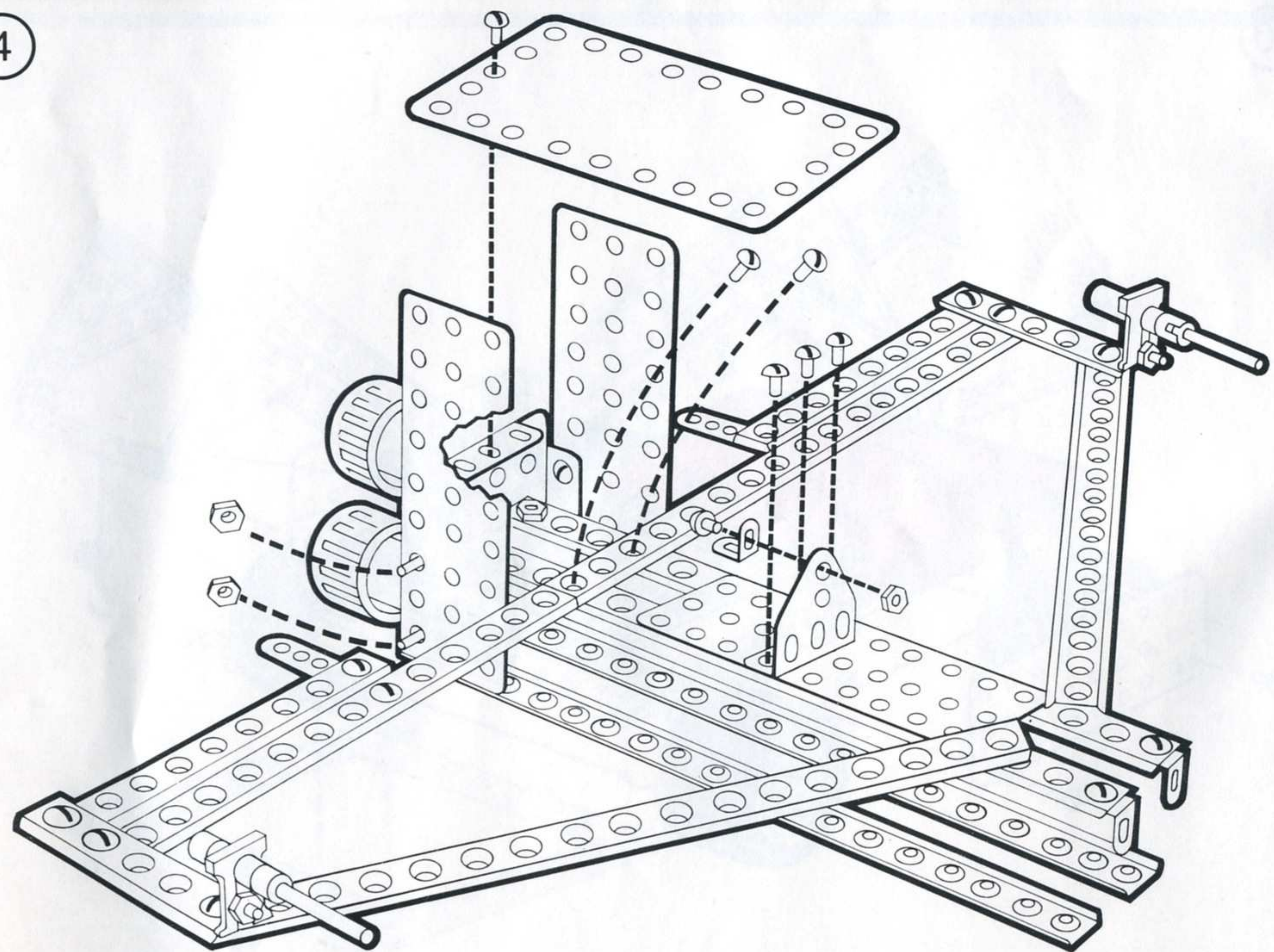



5

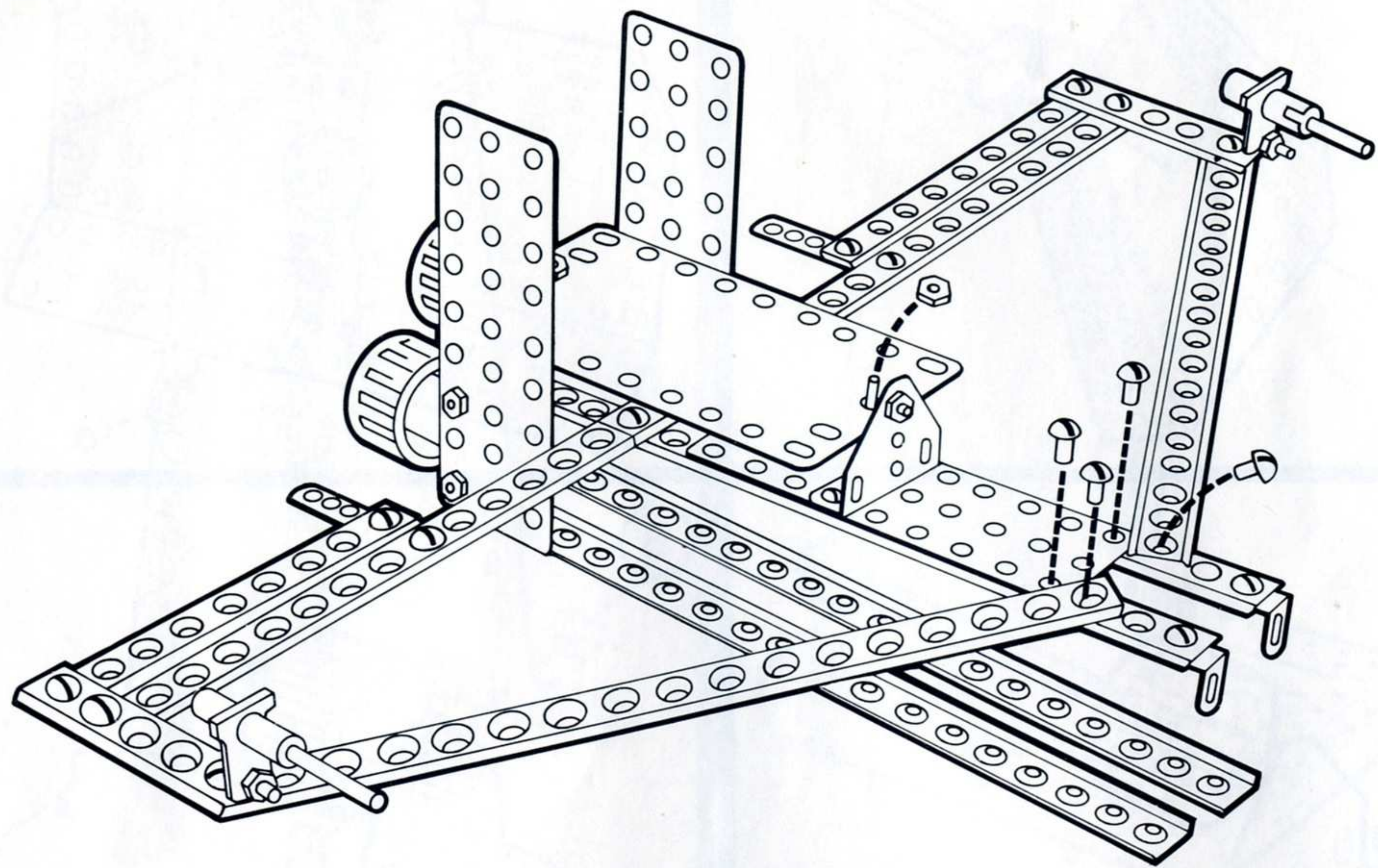

7

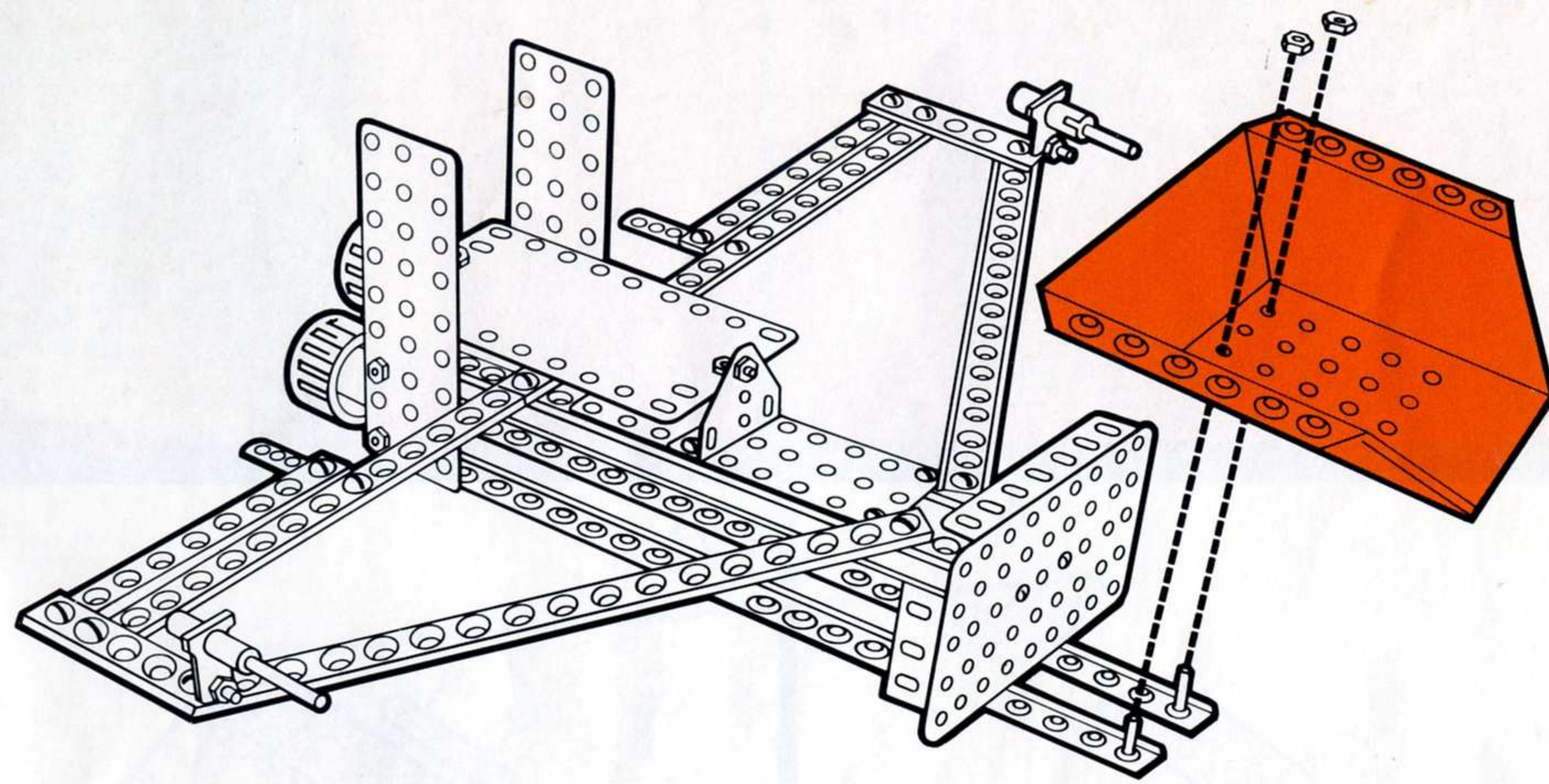

6

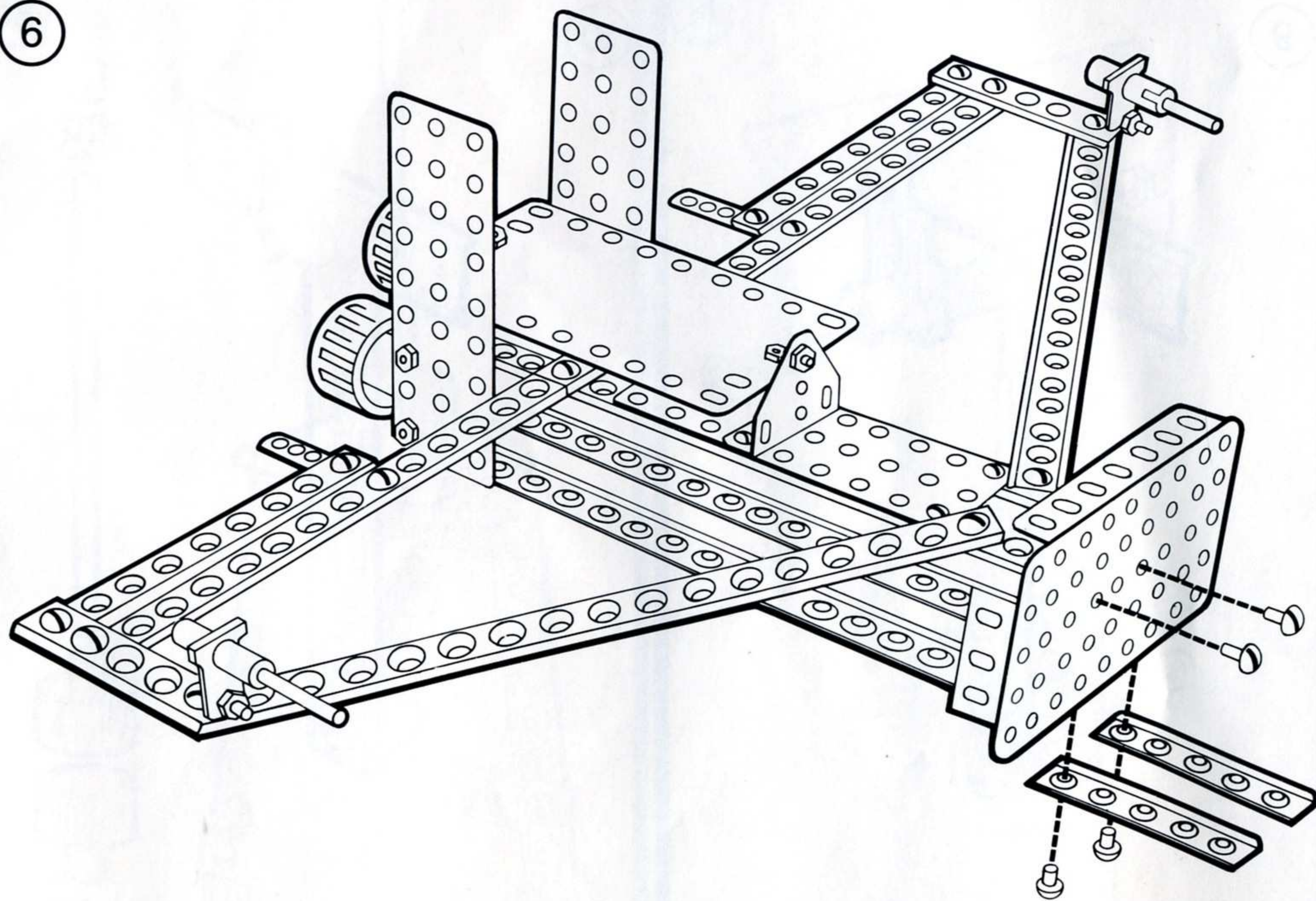

8

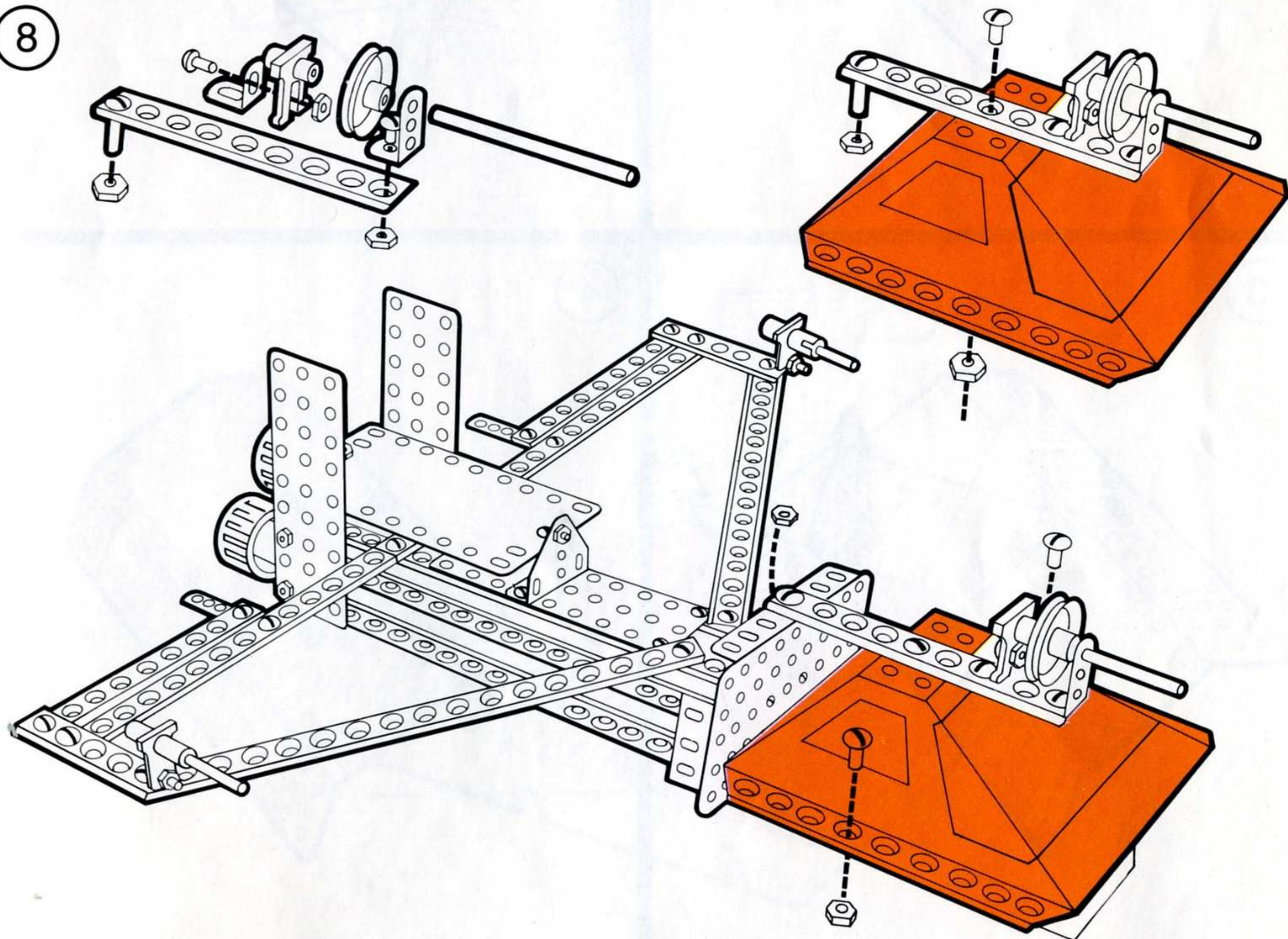



# DEEP SPACE RADAR STATION

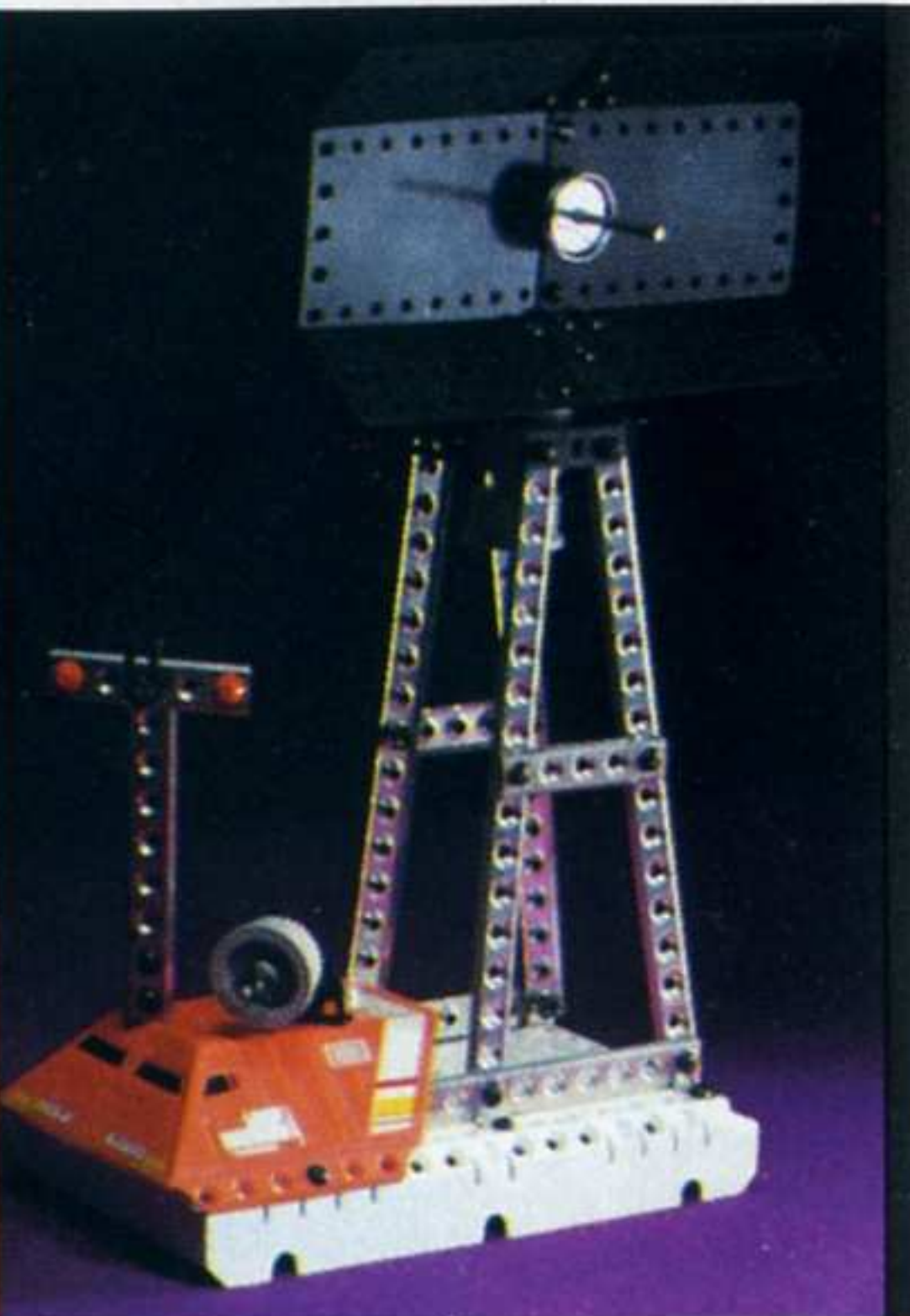

1

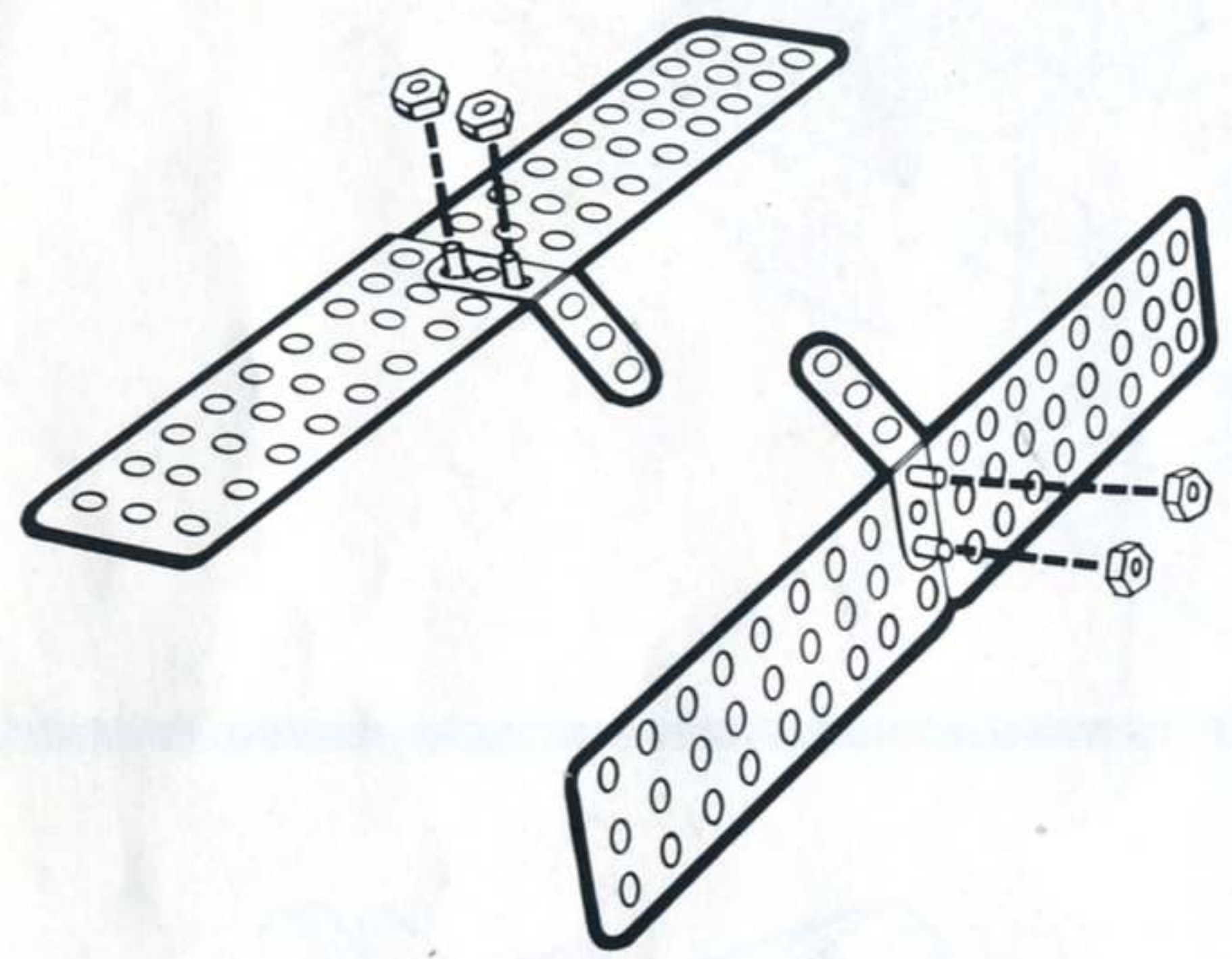

2

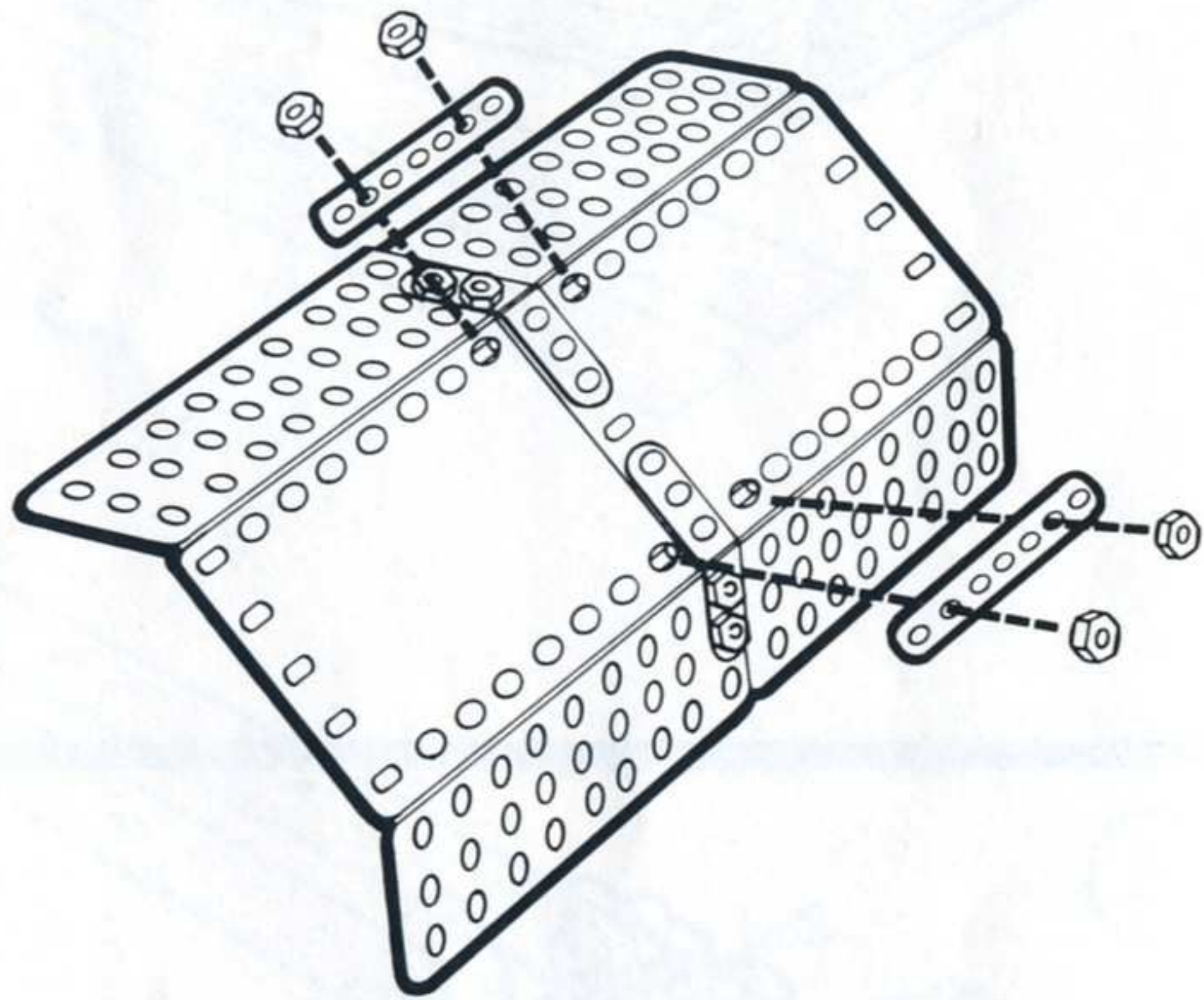

3

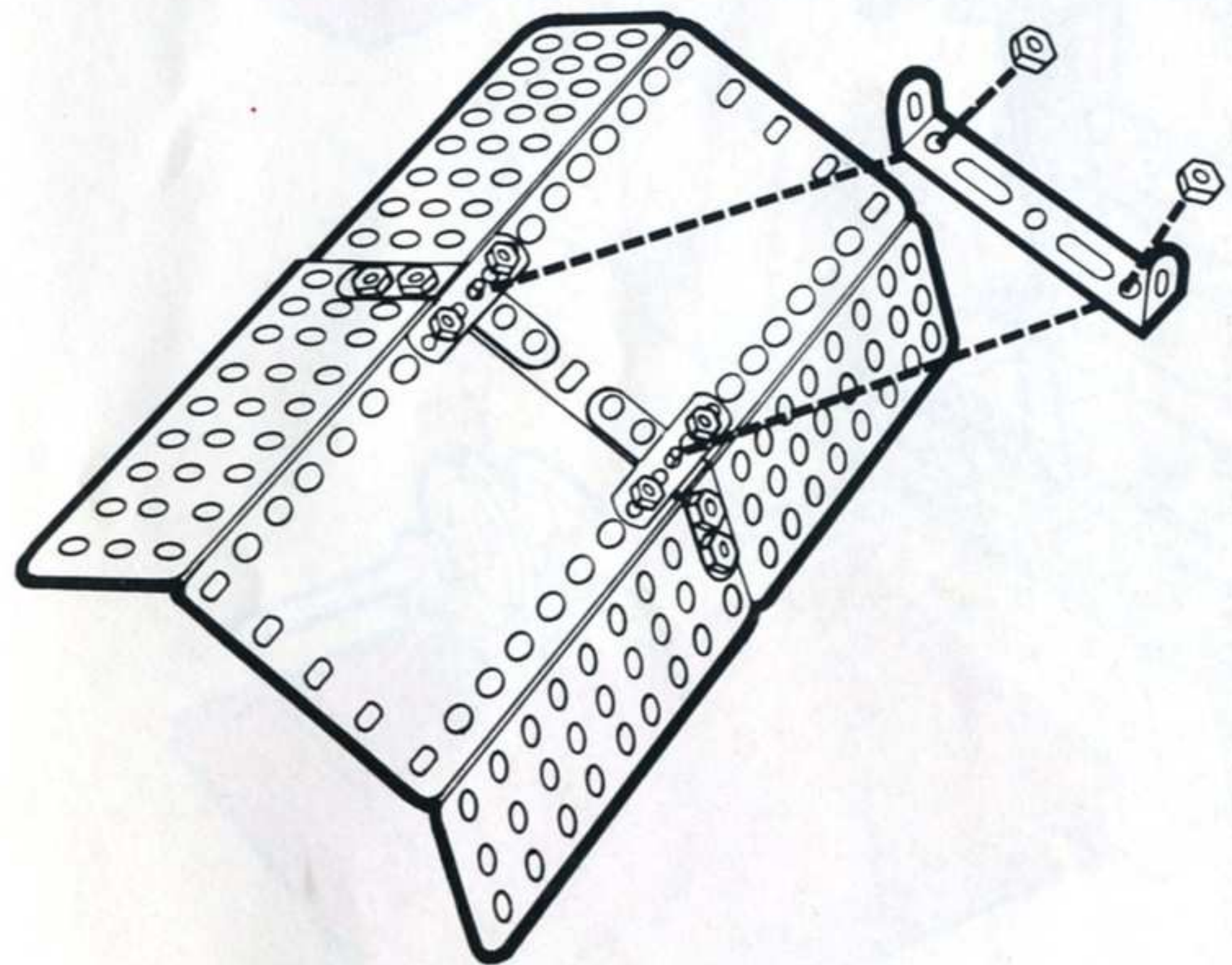

4

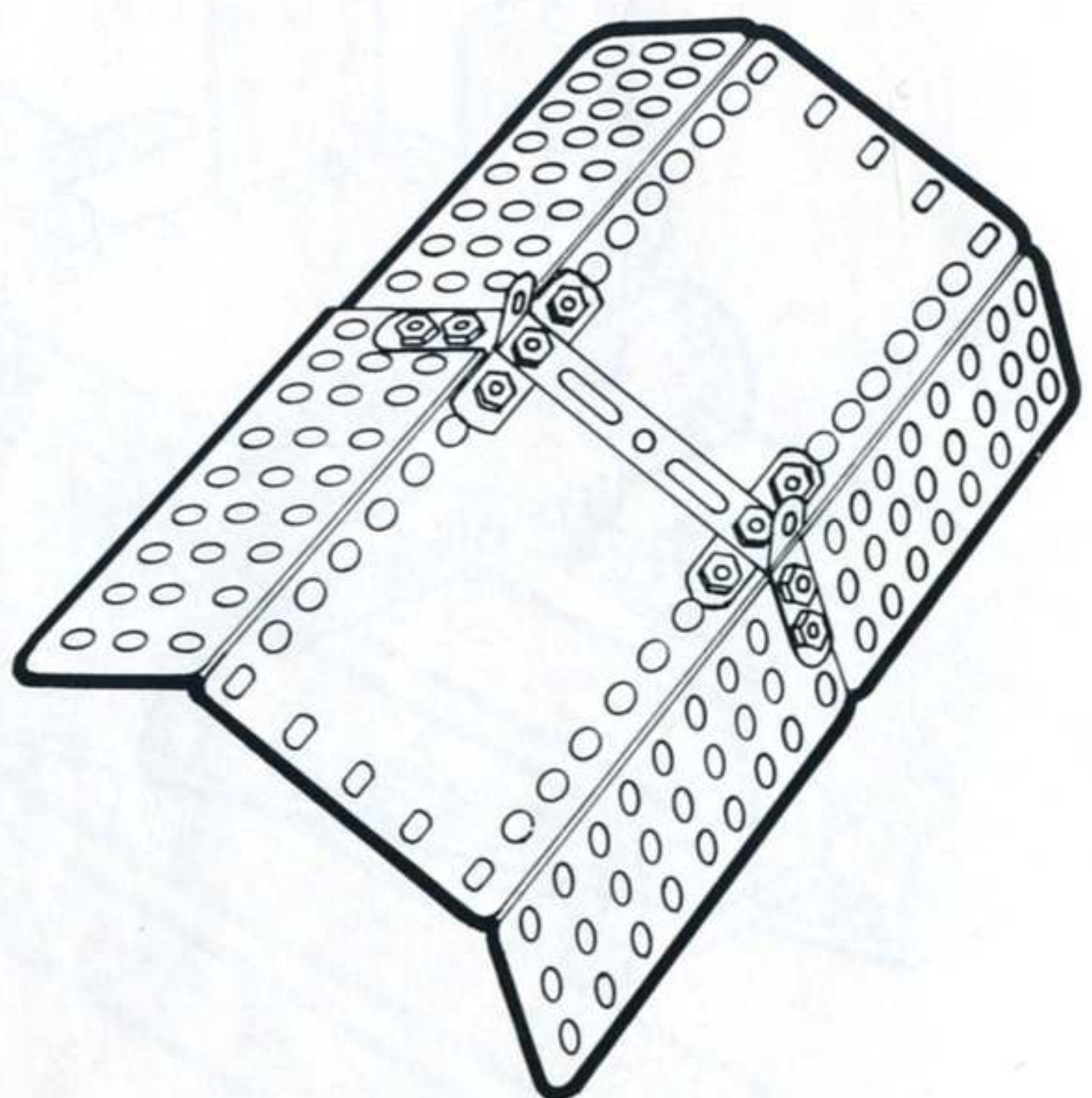

5

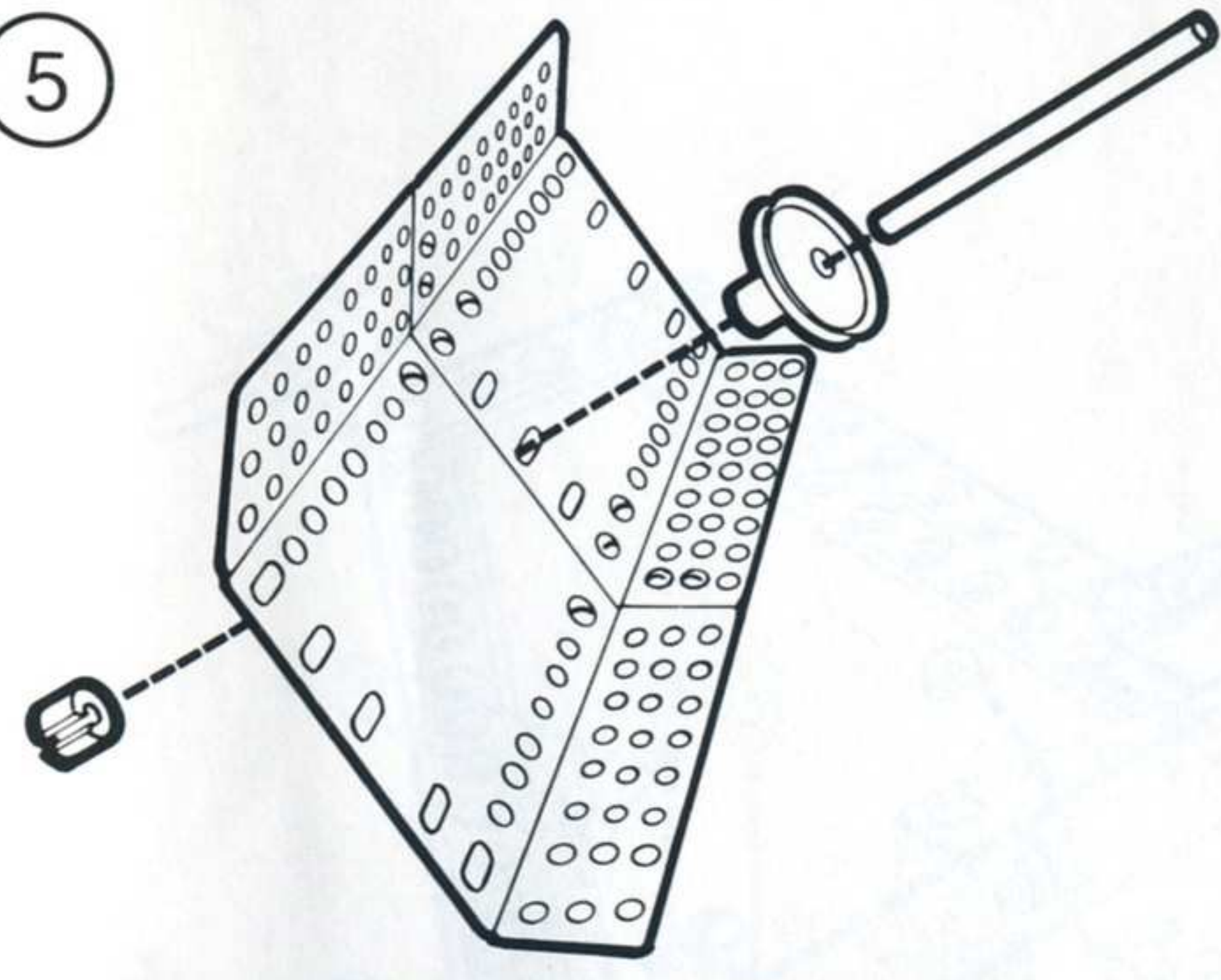

6

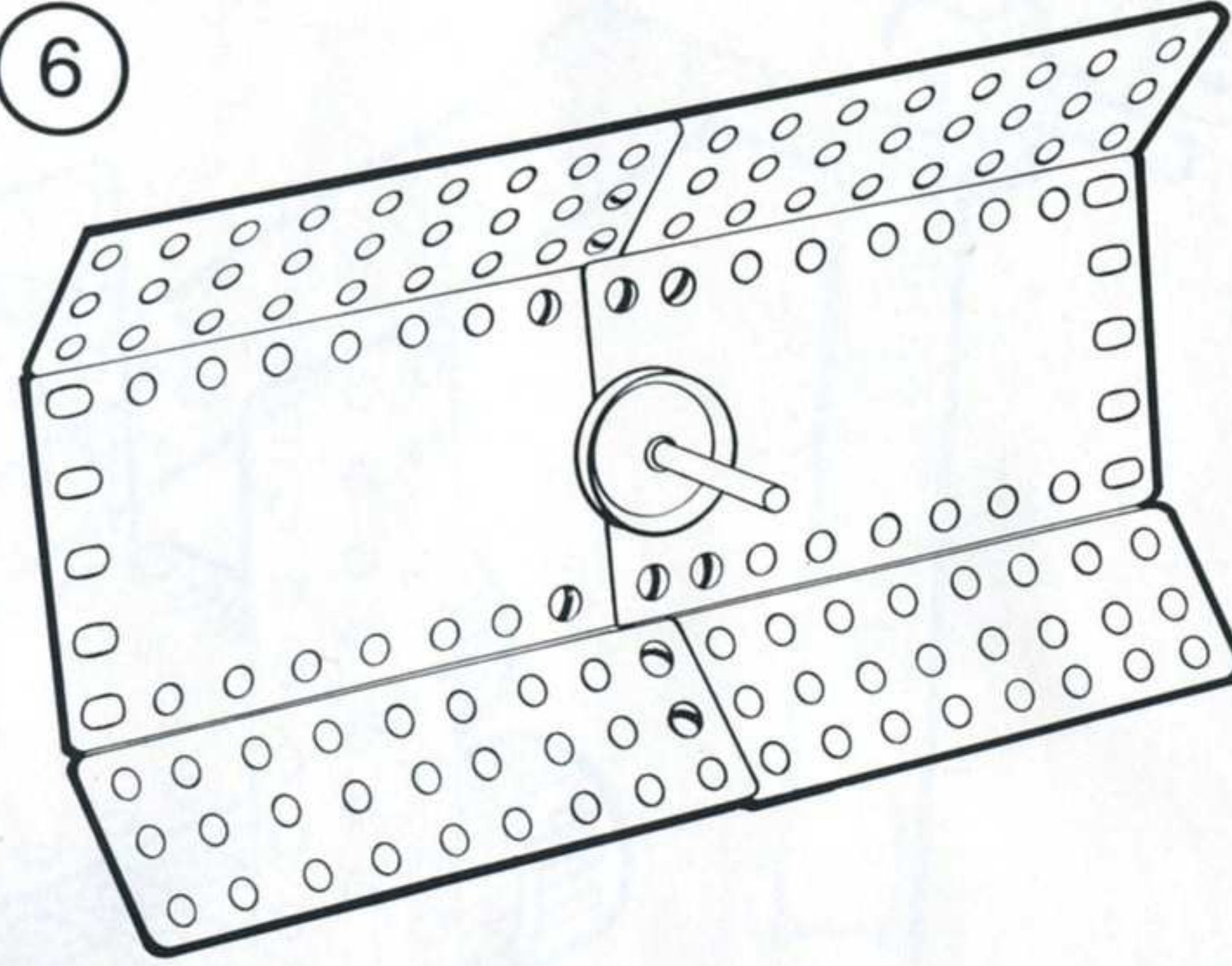

7

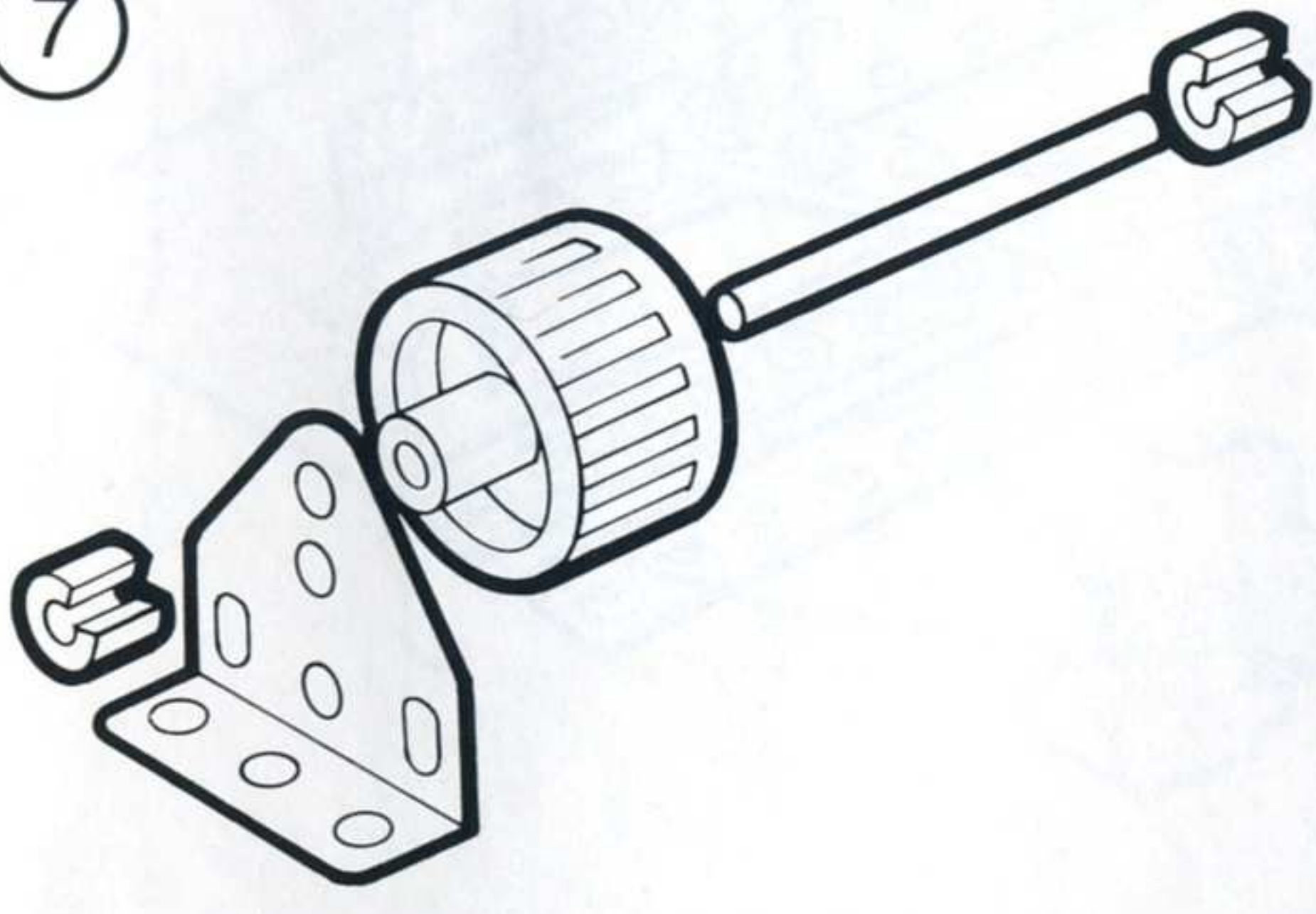

8

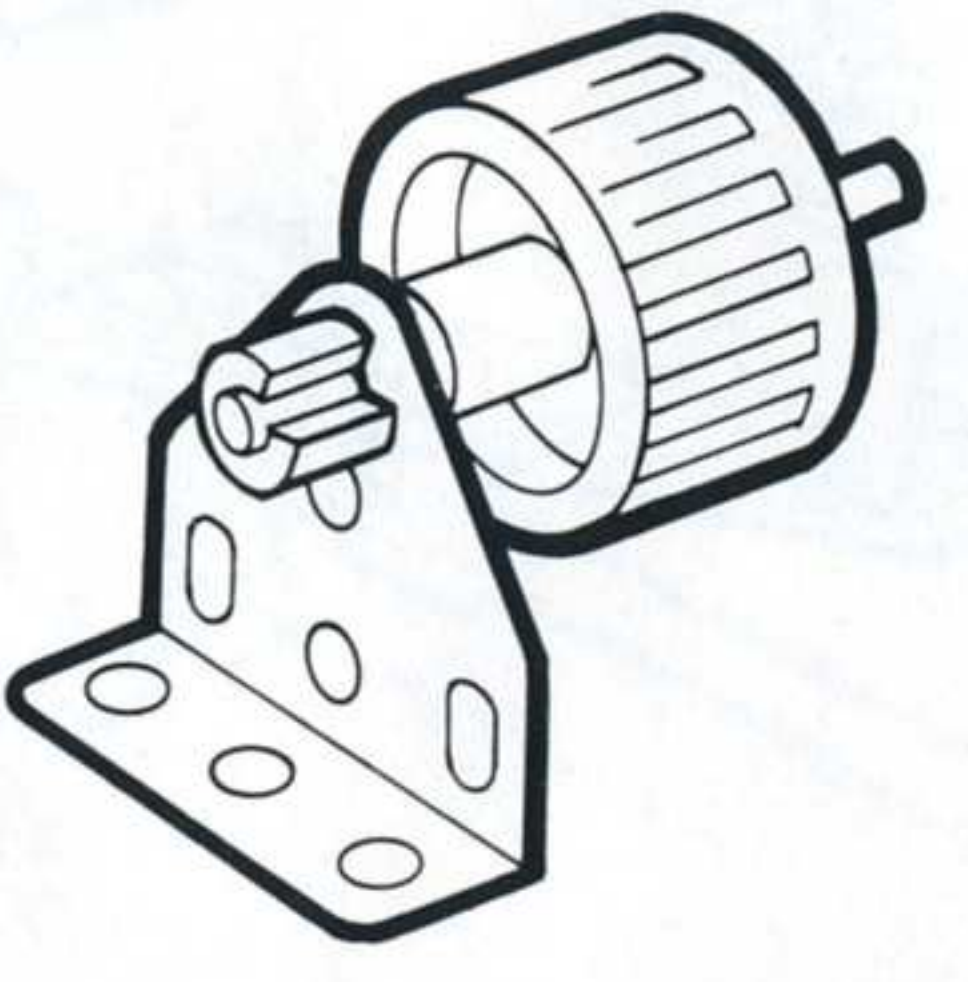

9

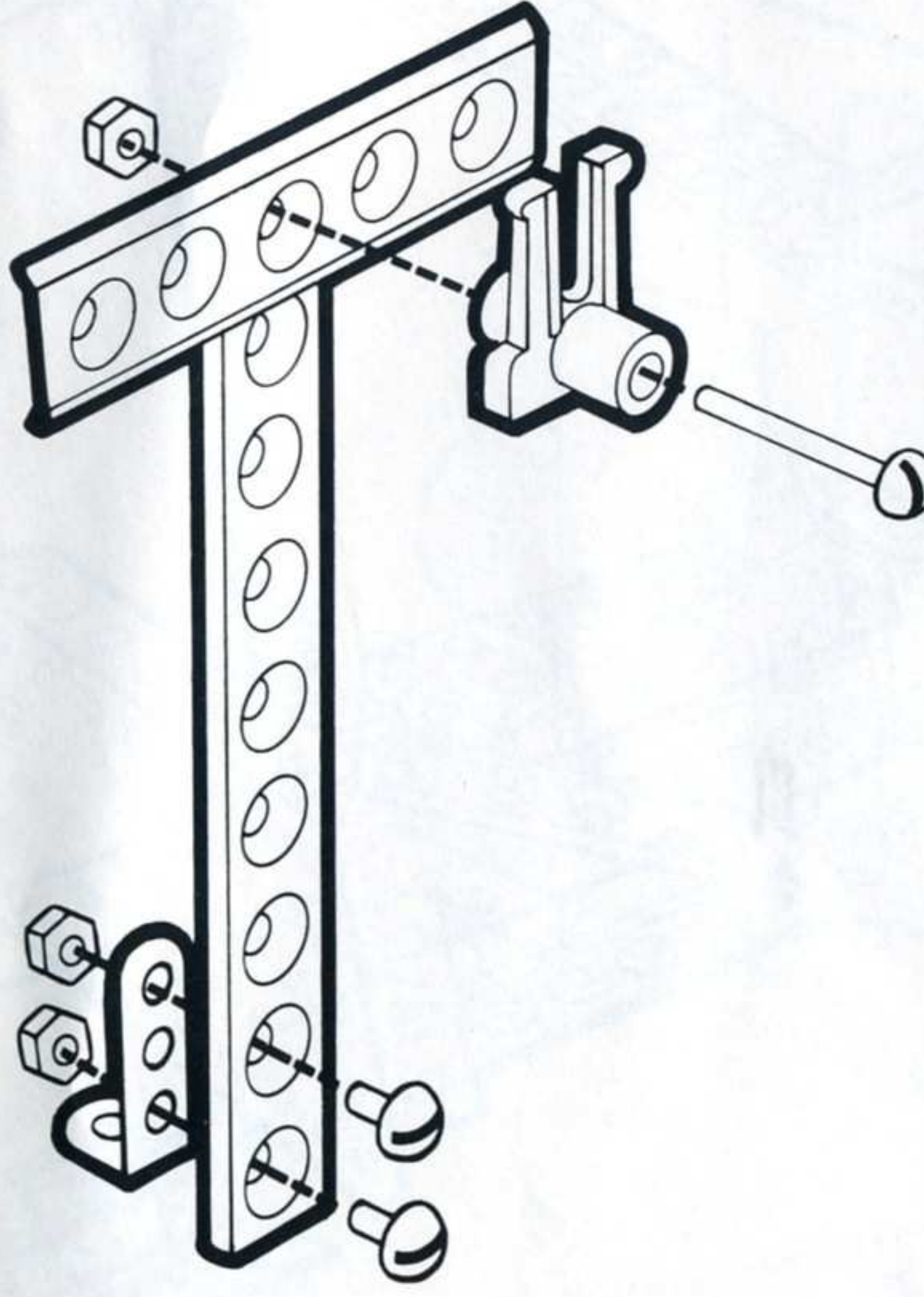

10

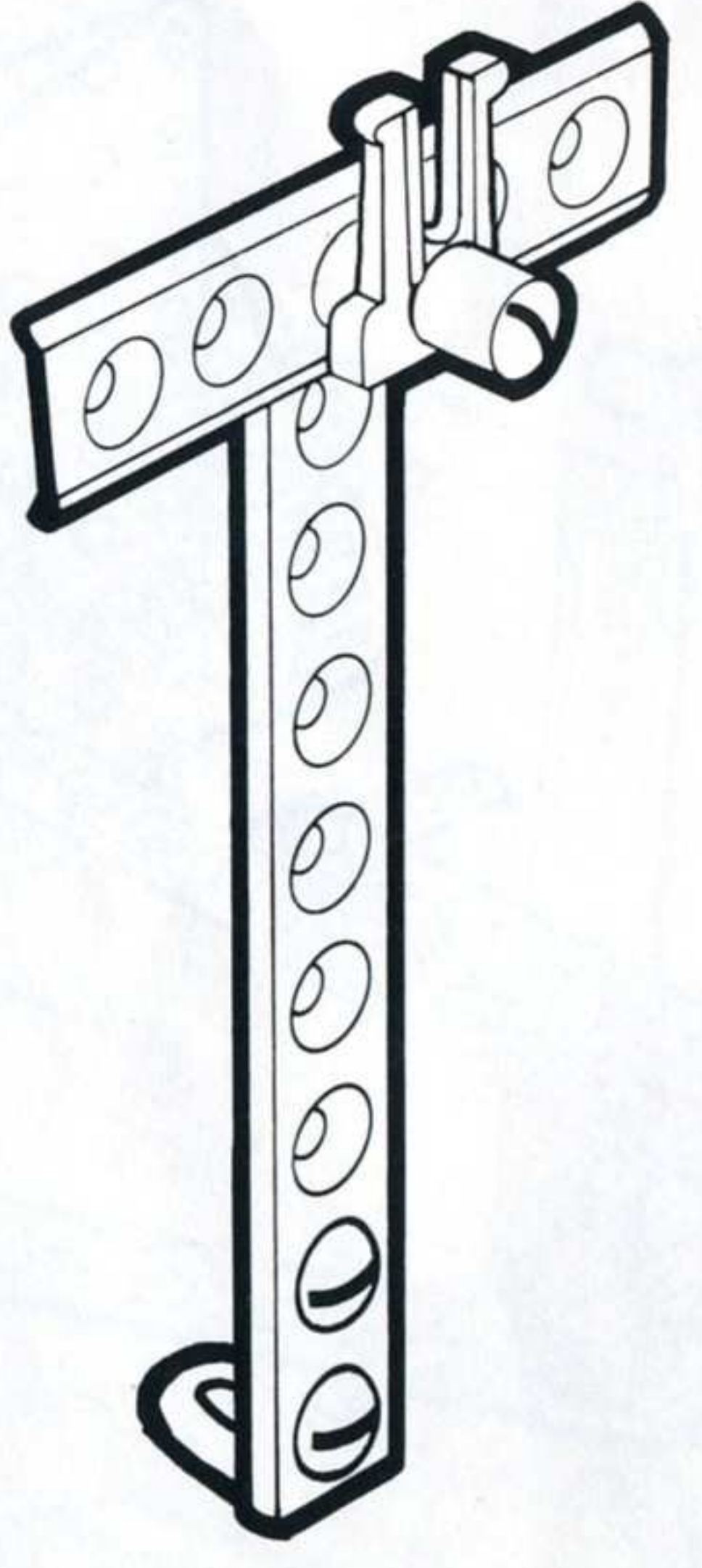



11

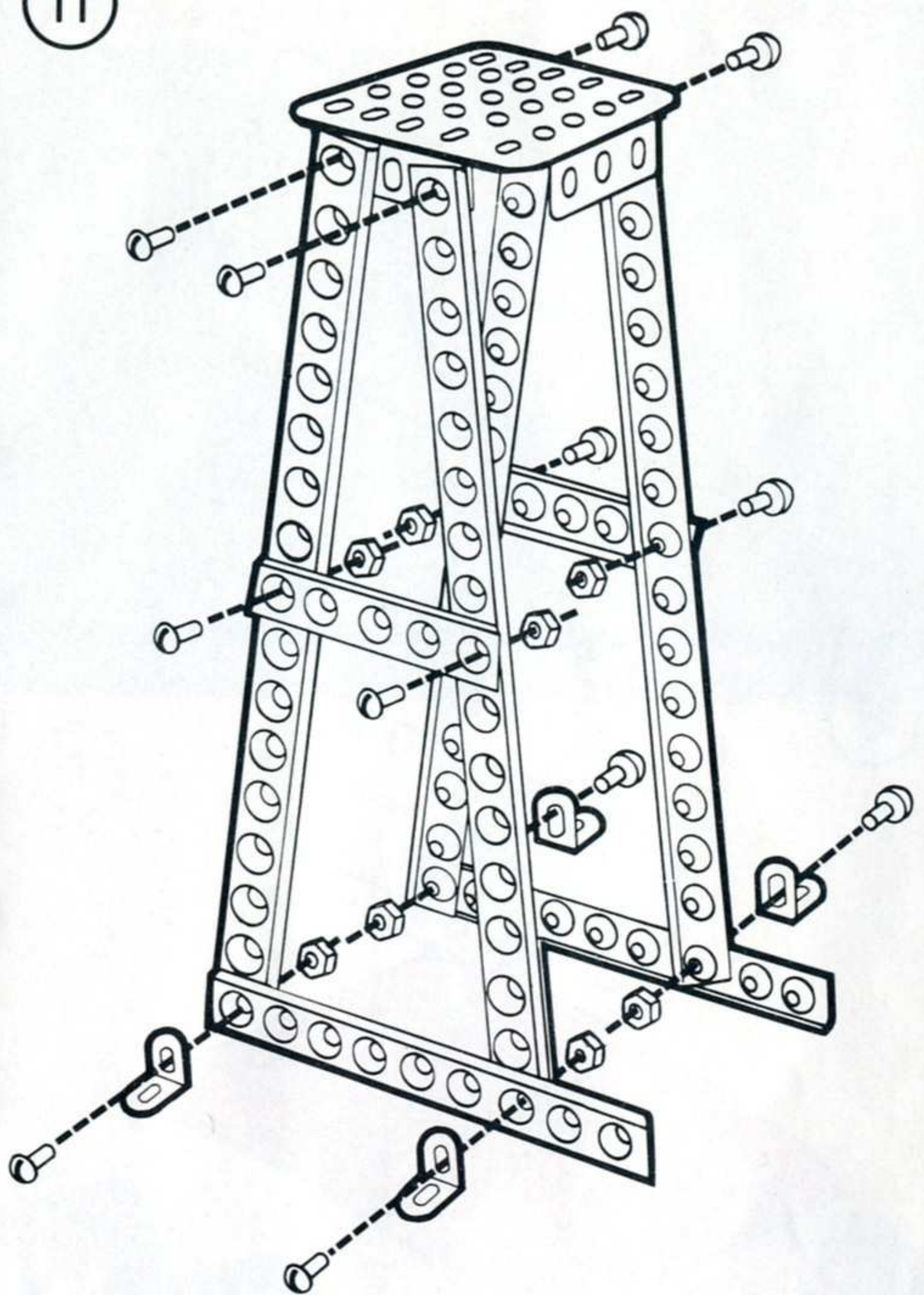

12

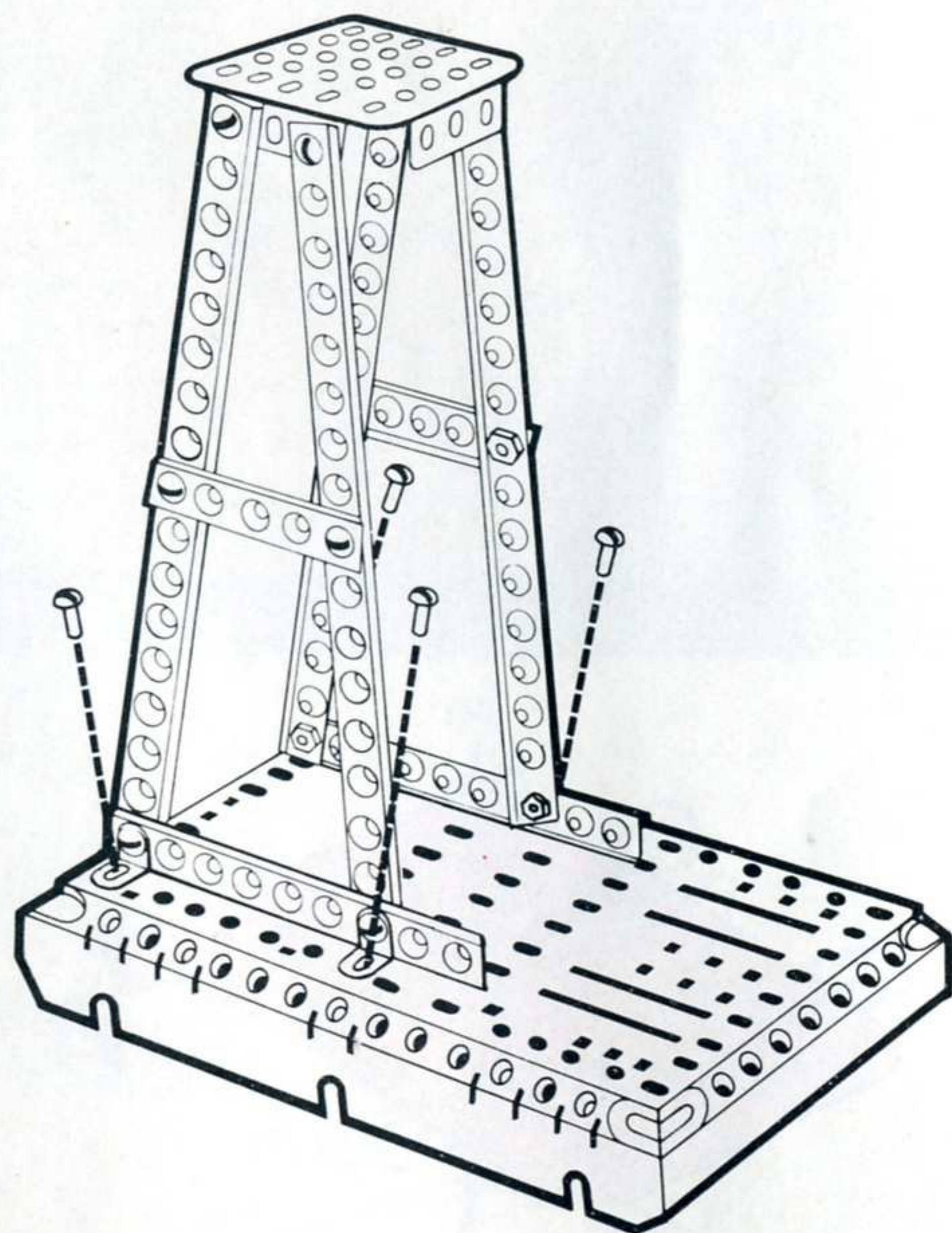

13

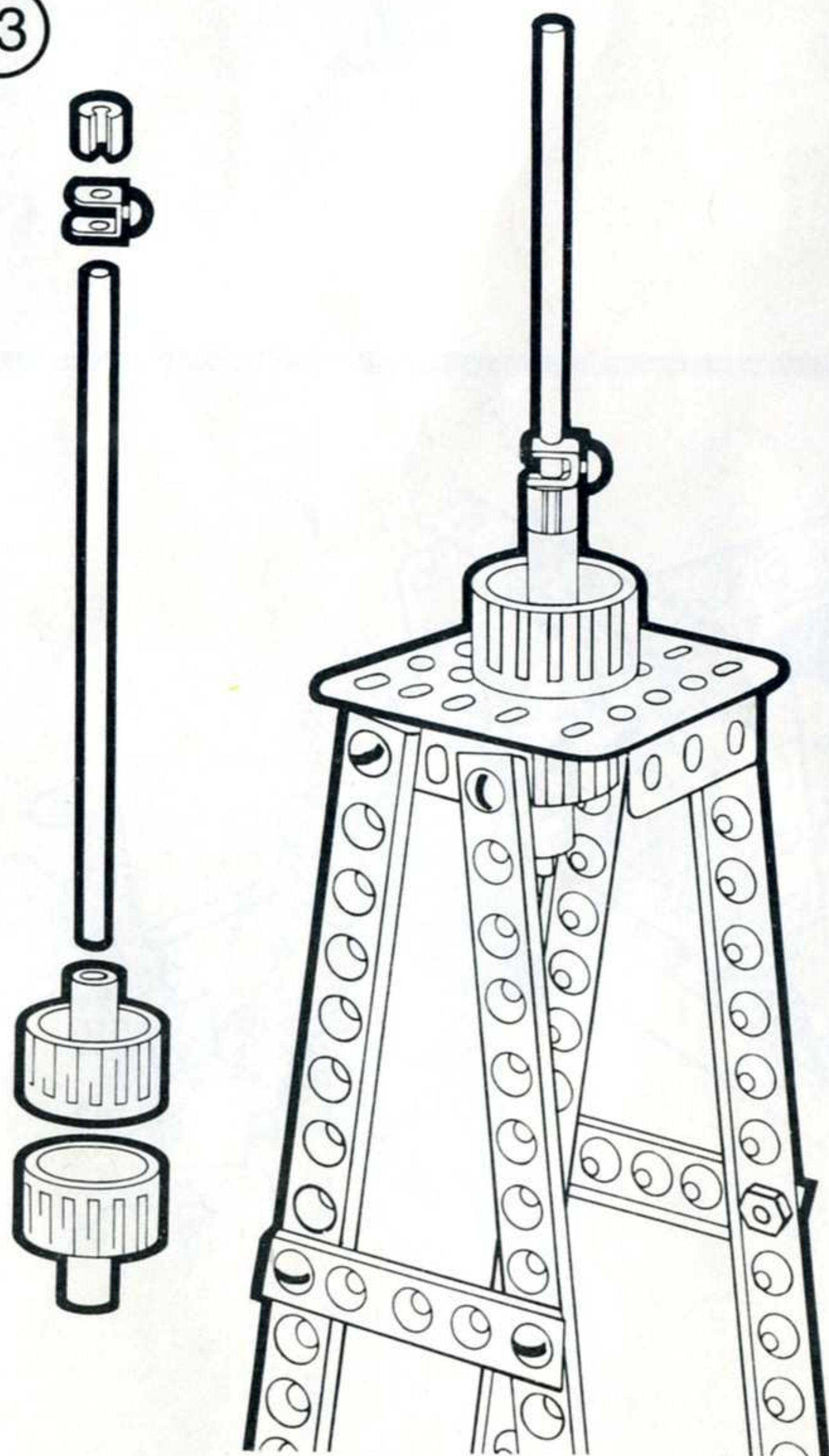

14

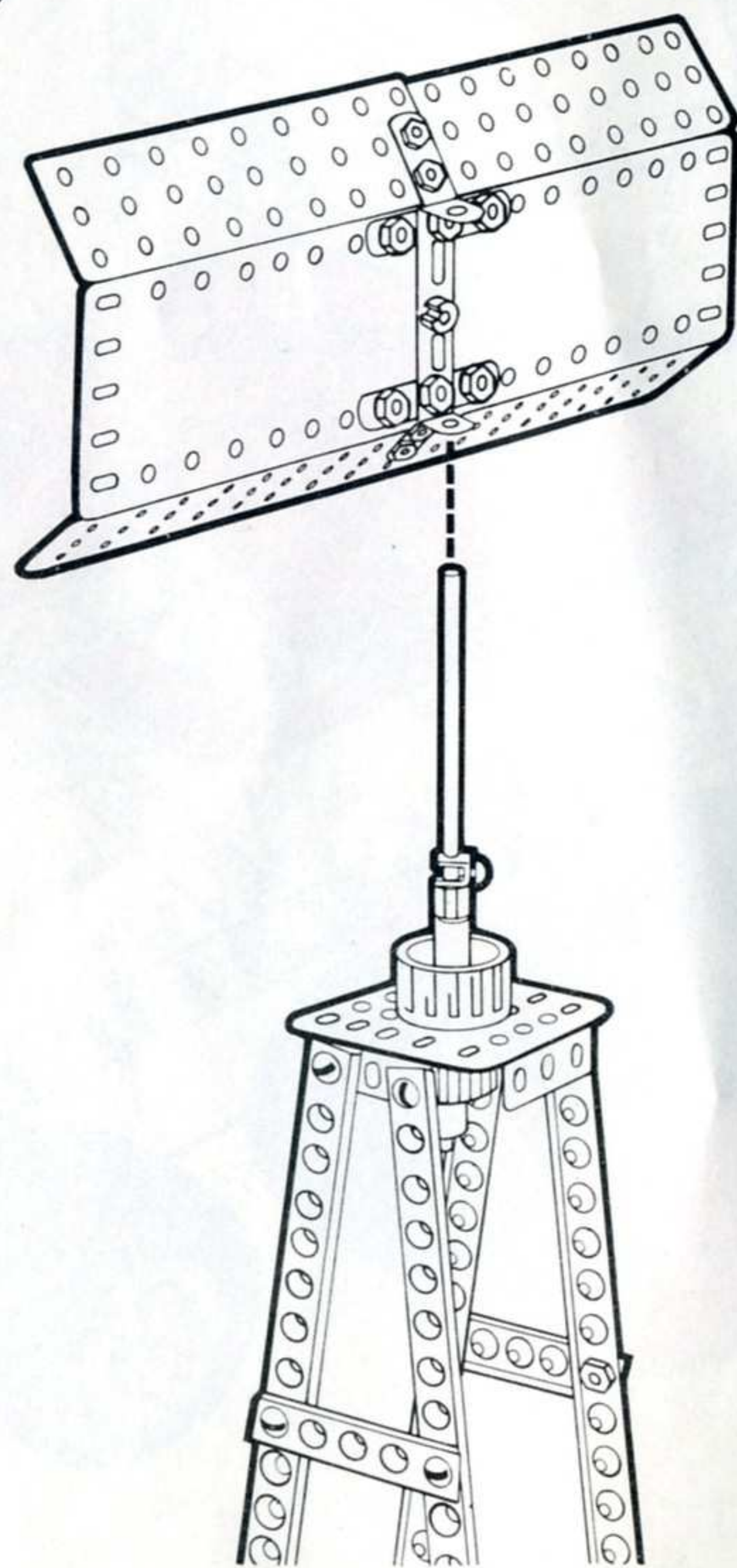

15

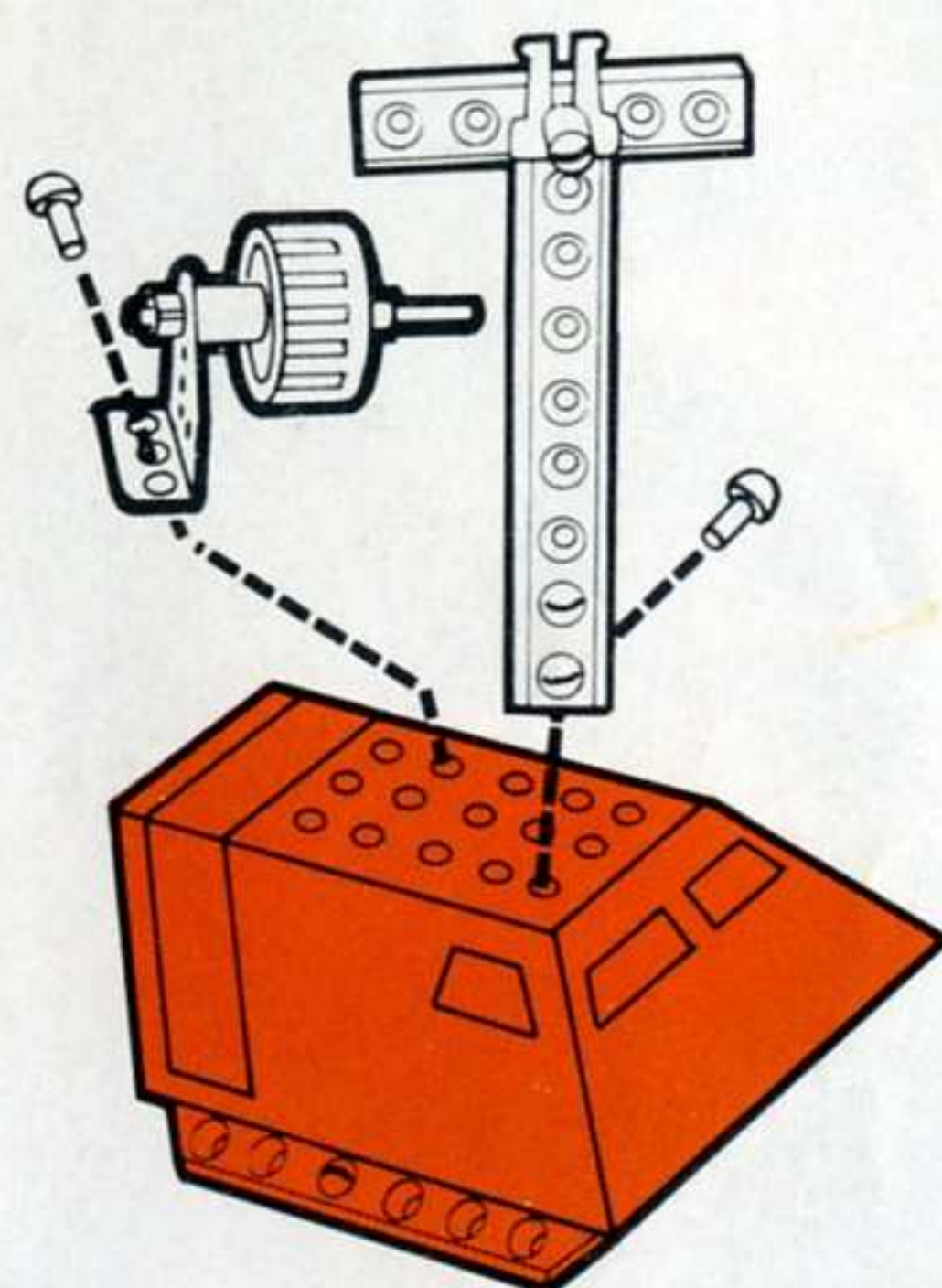

16

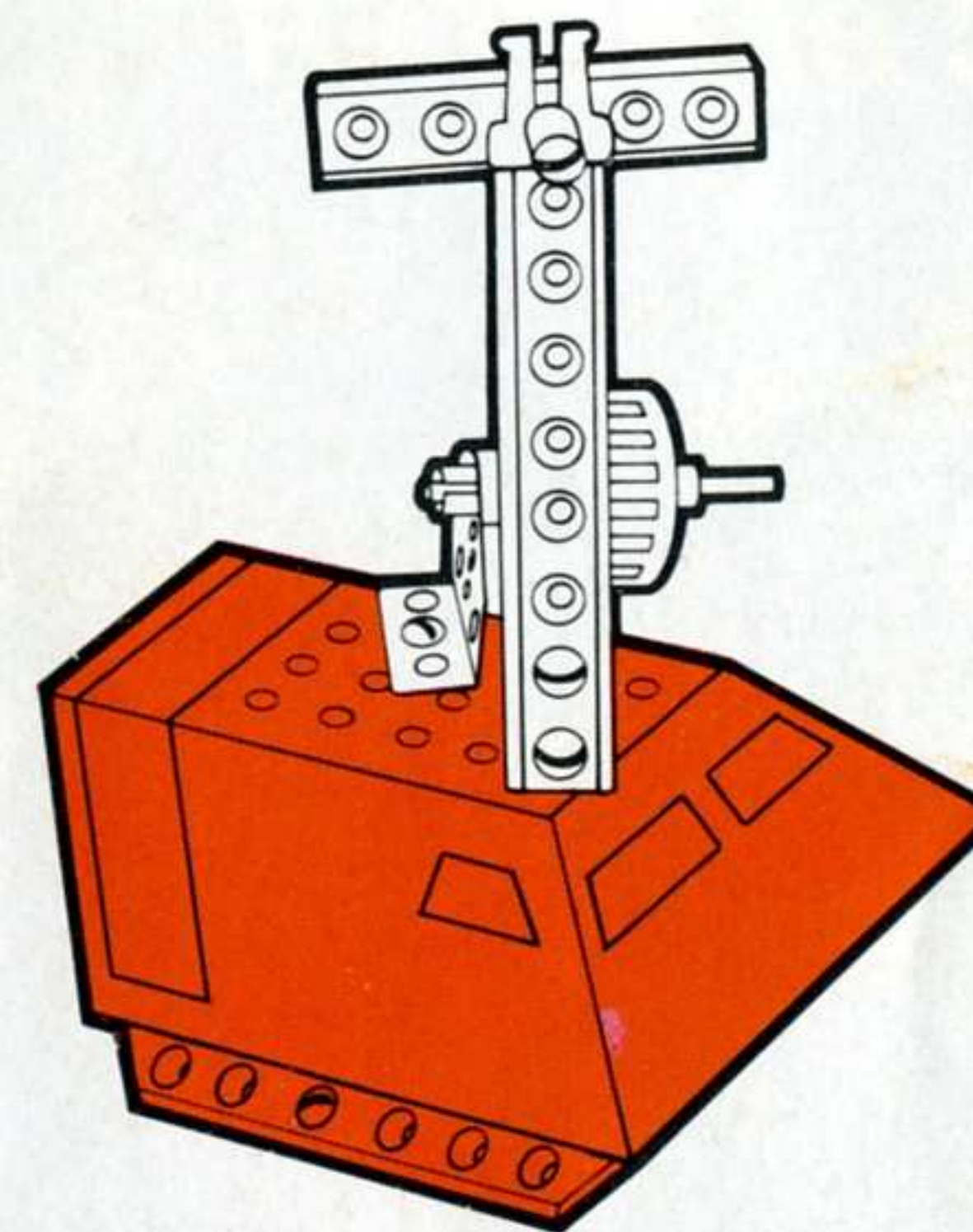

17

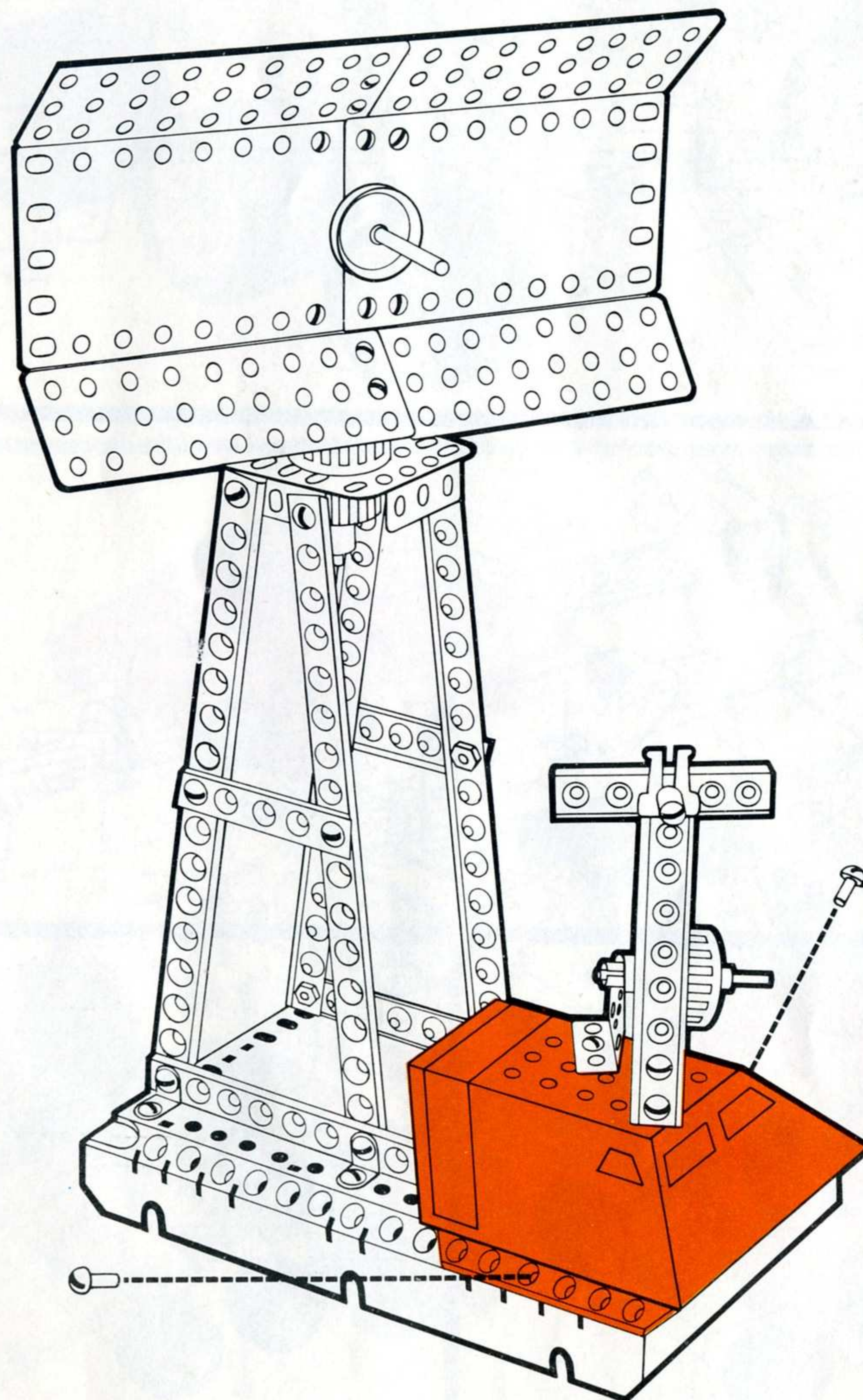



# SONIC BLASTER

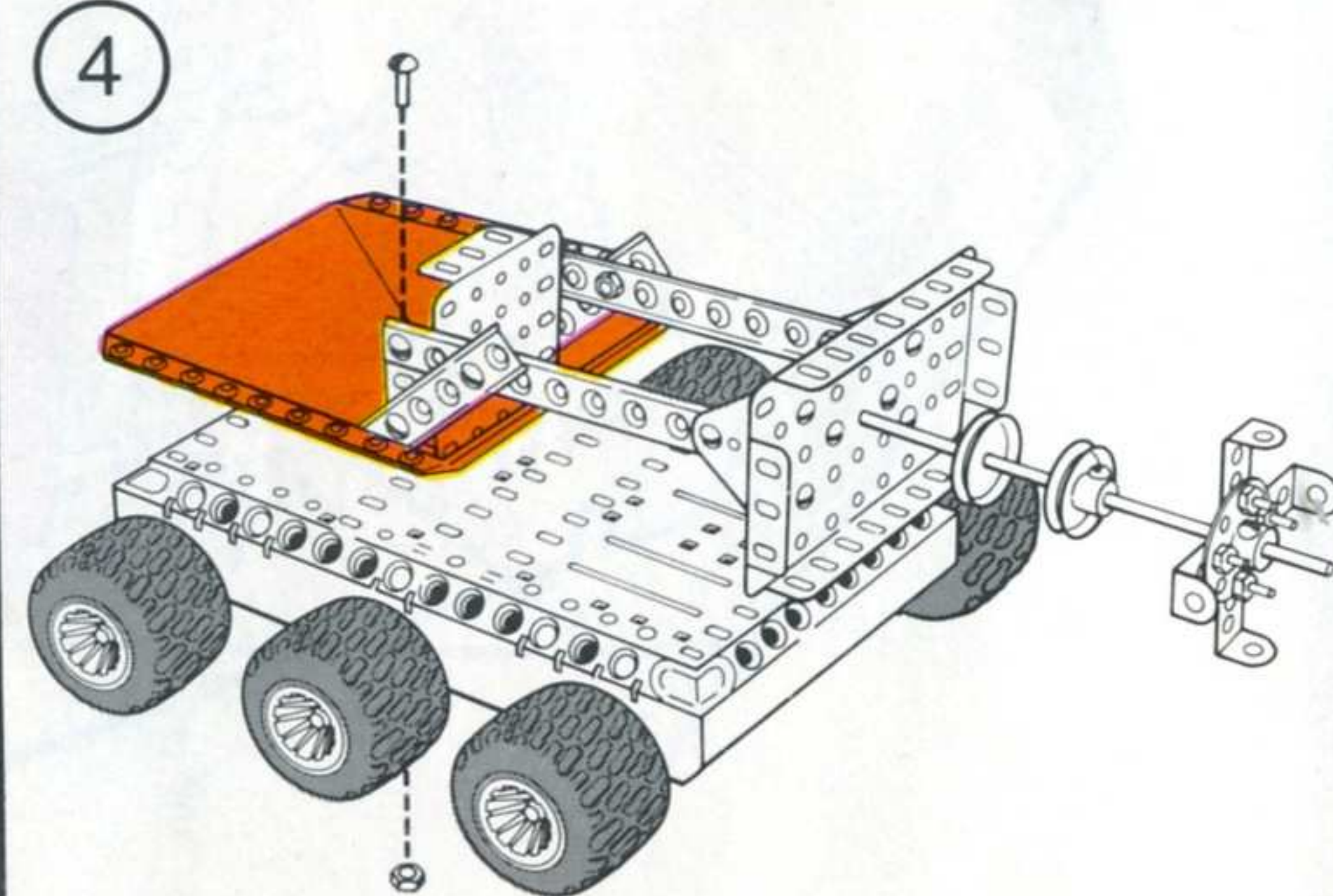
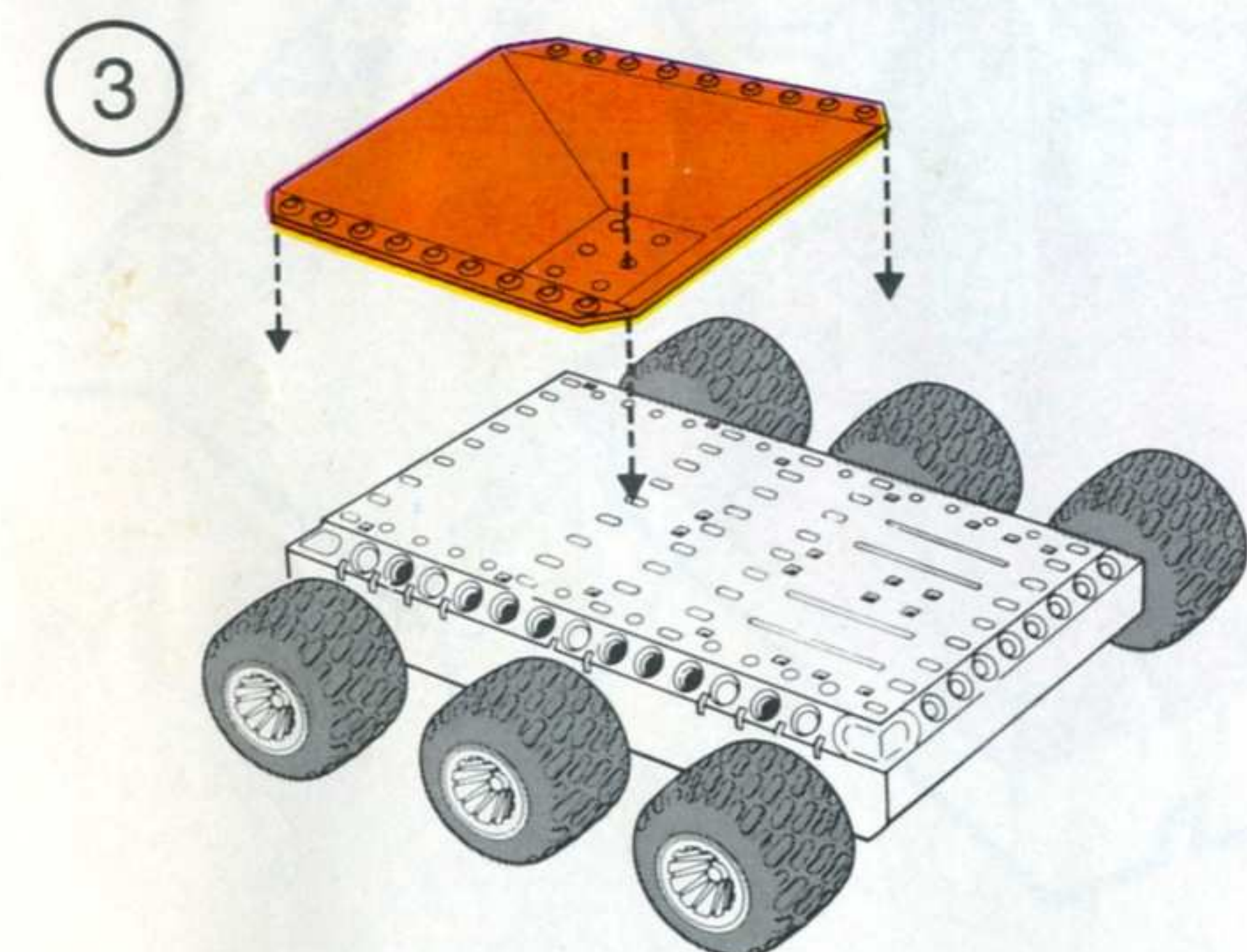
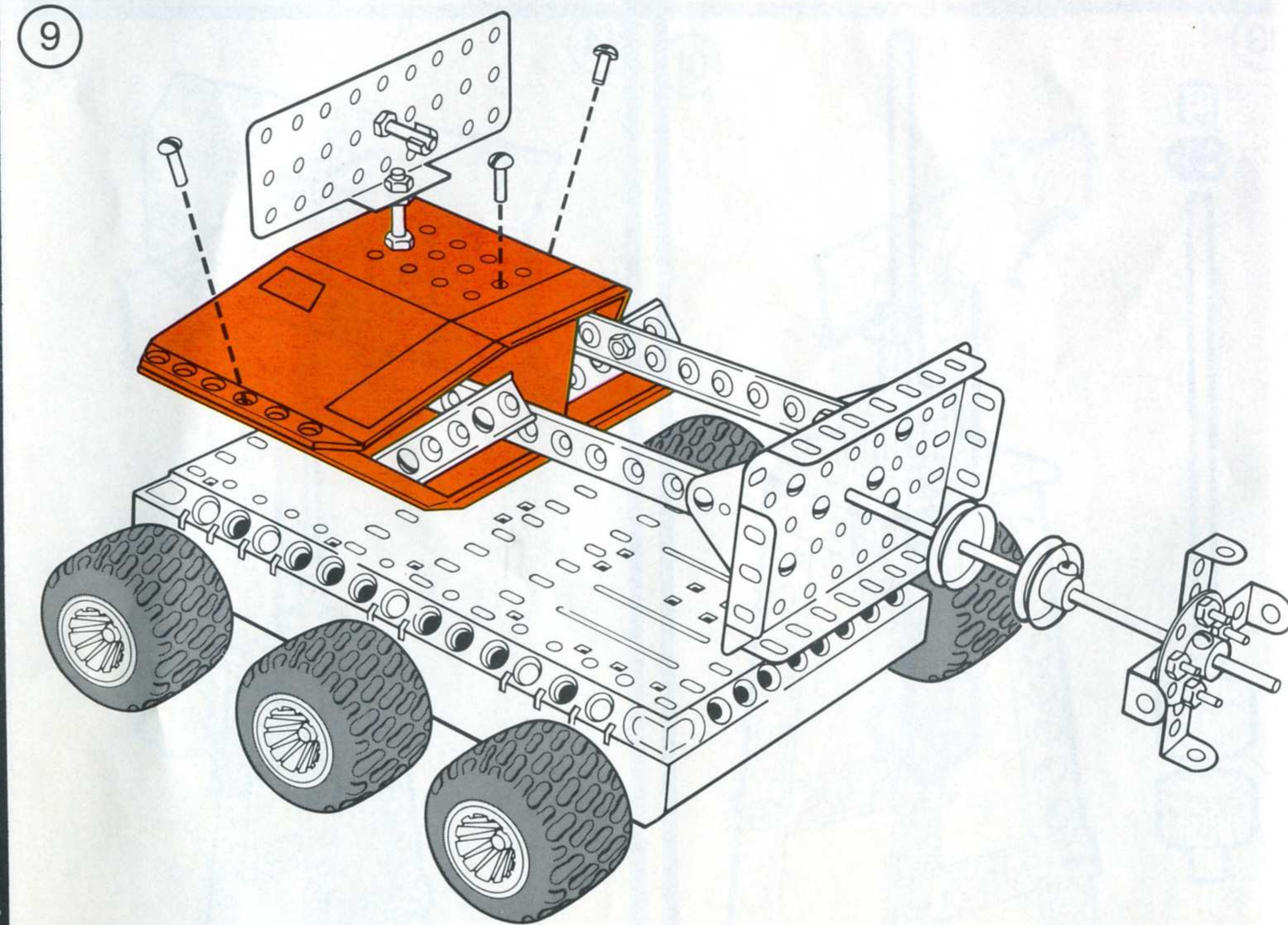
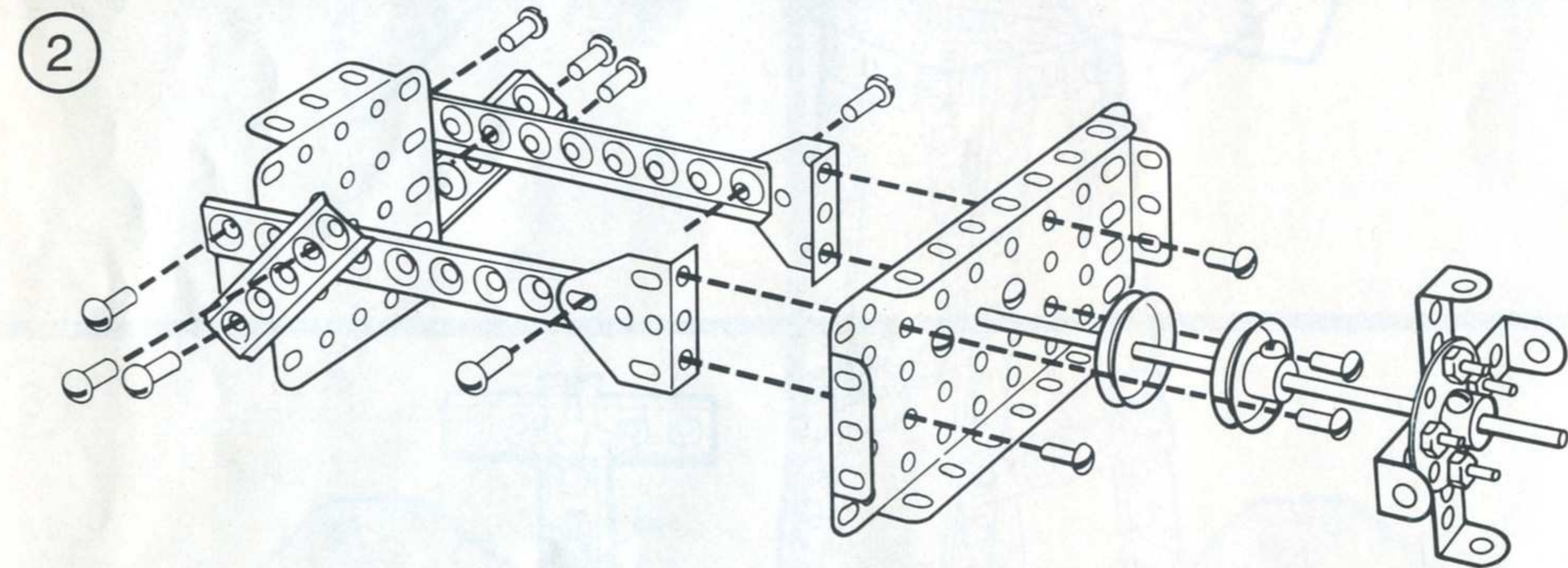
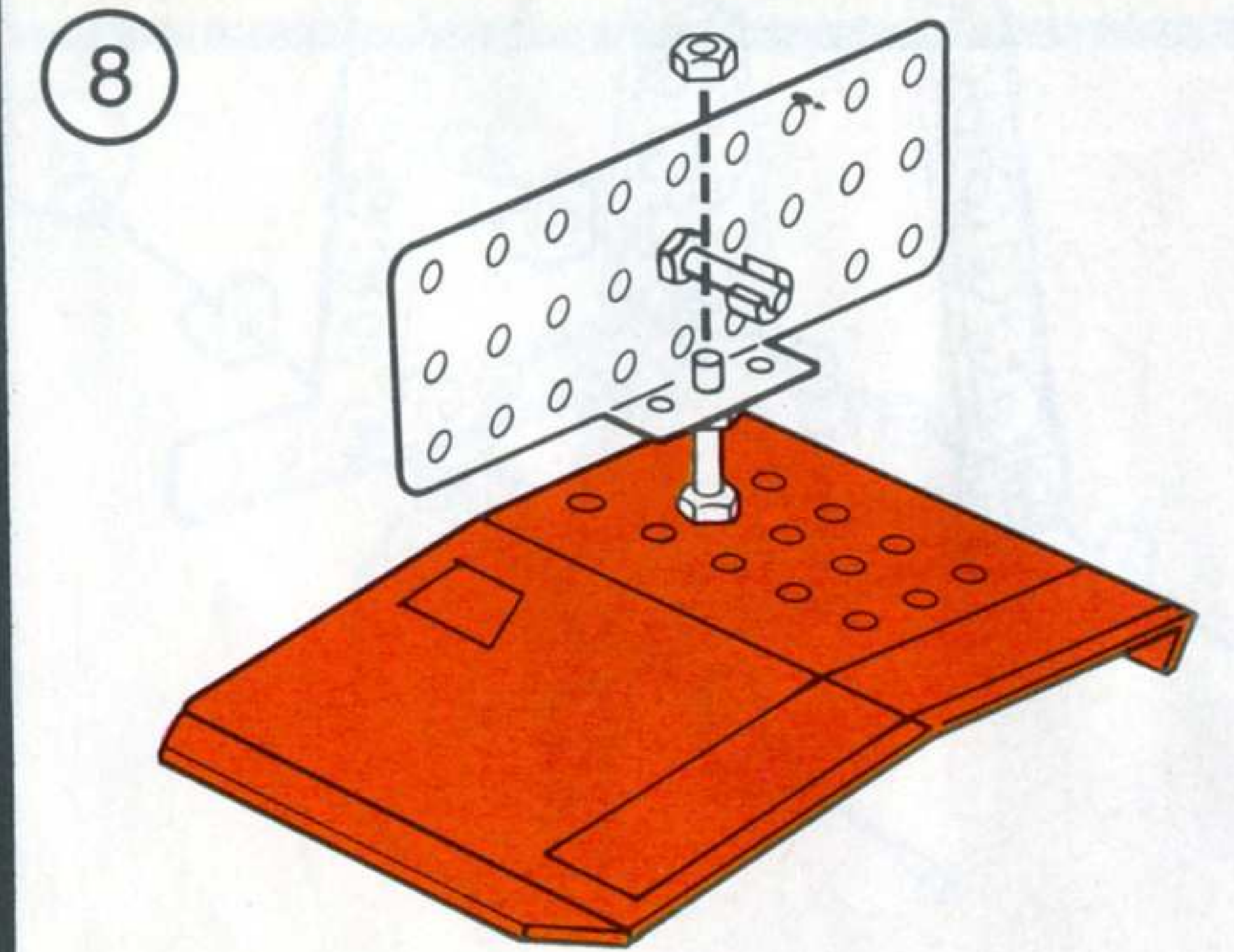
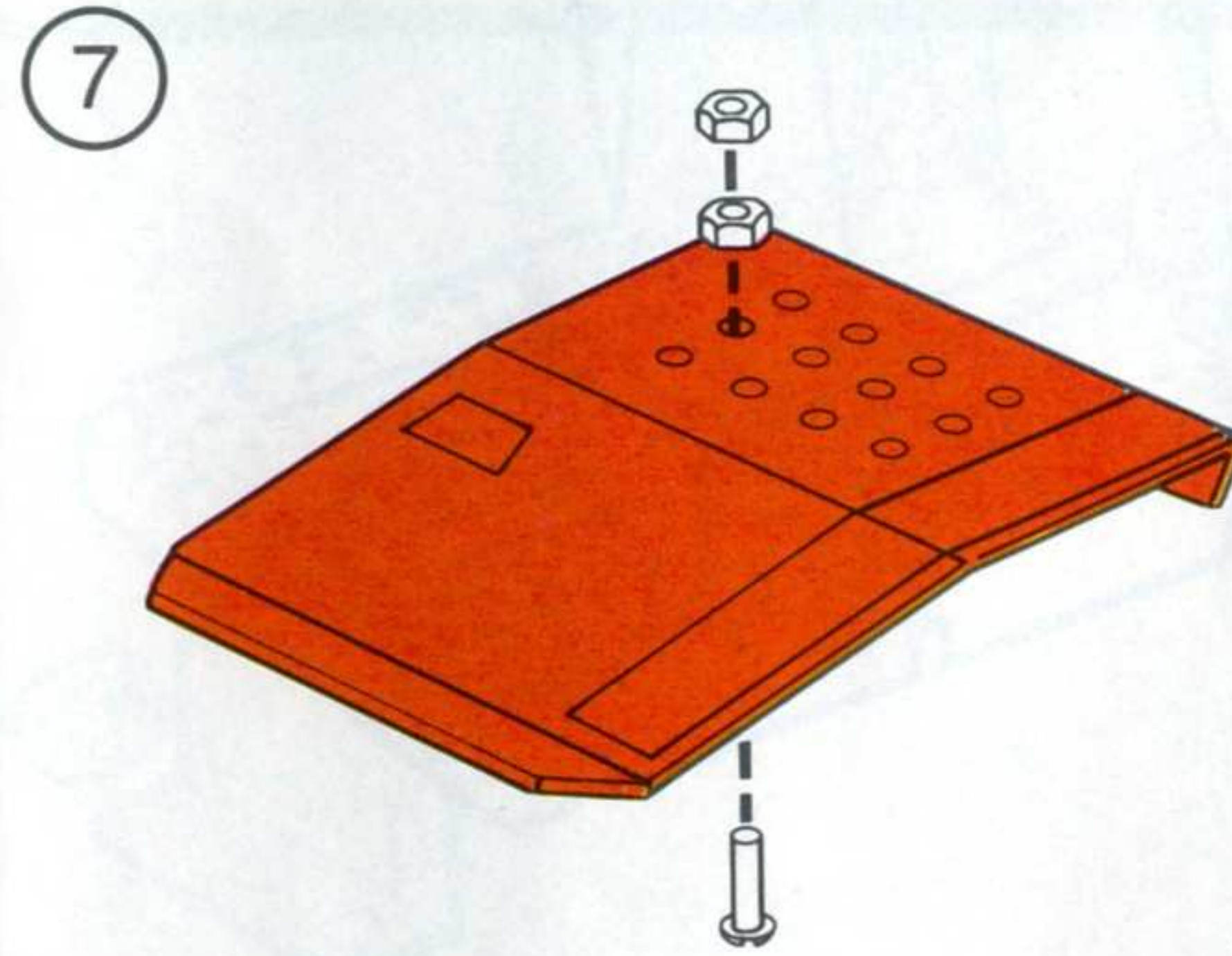
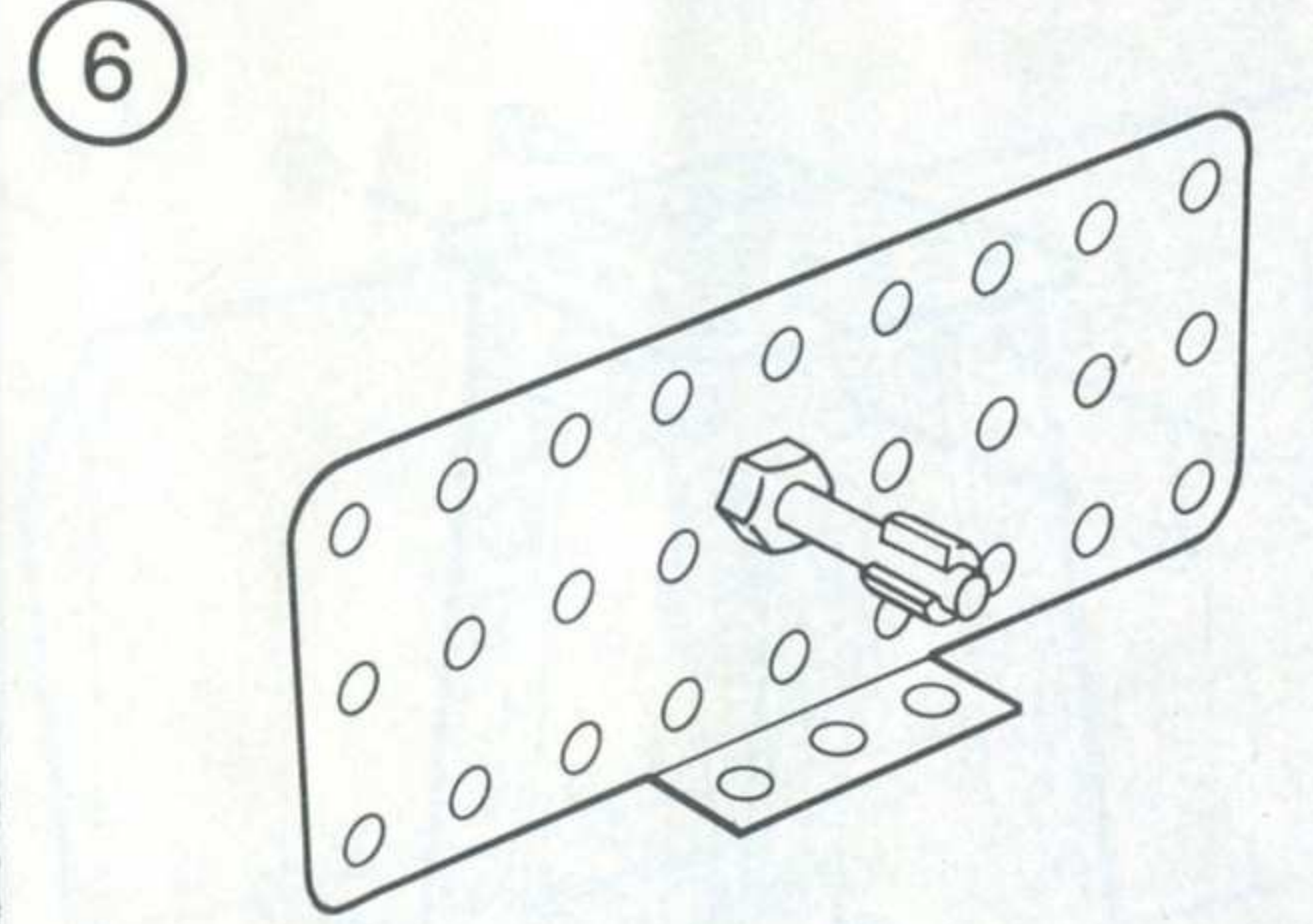
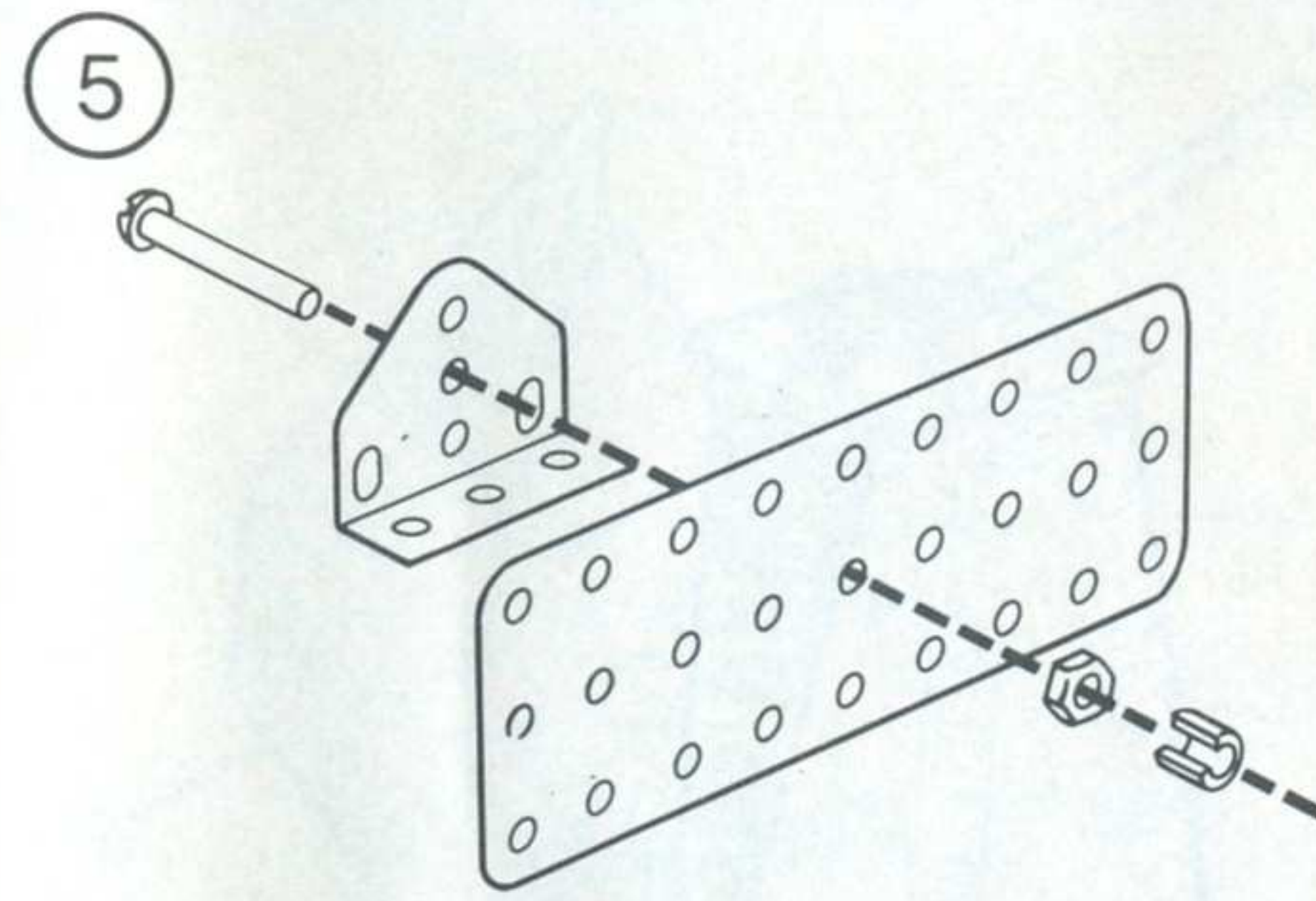
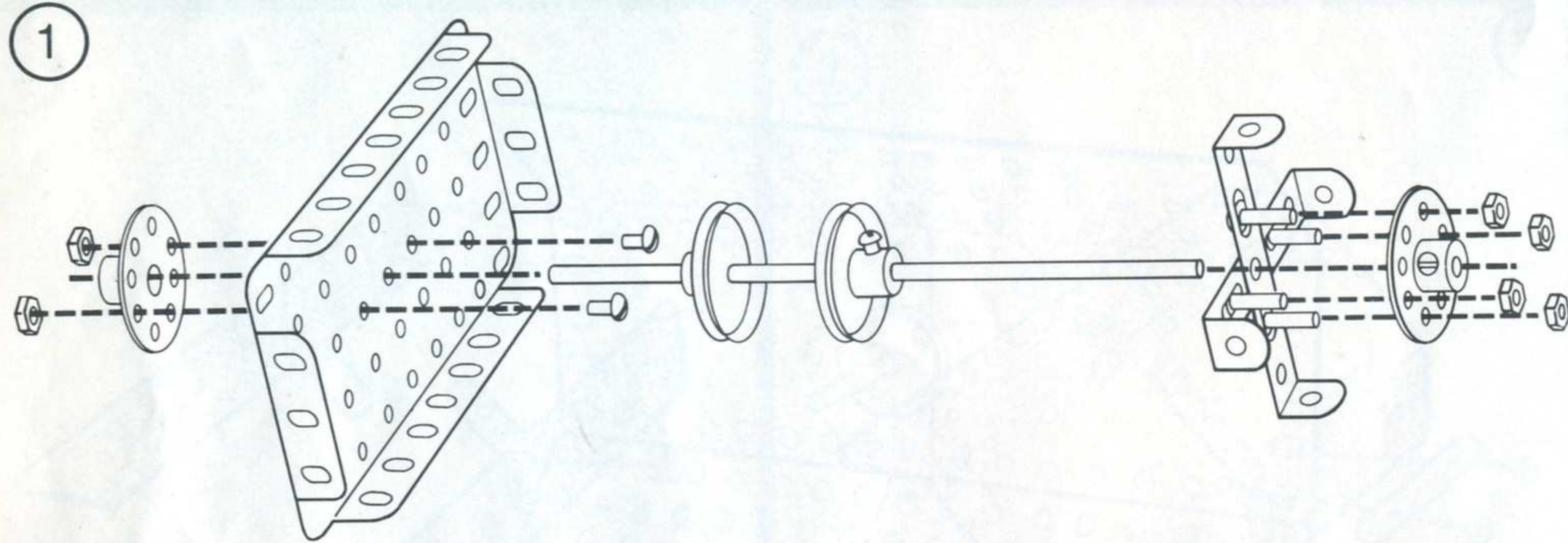
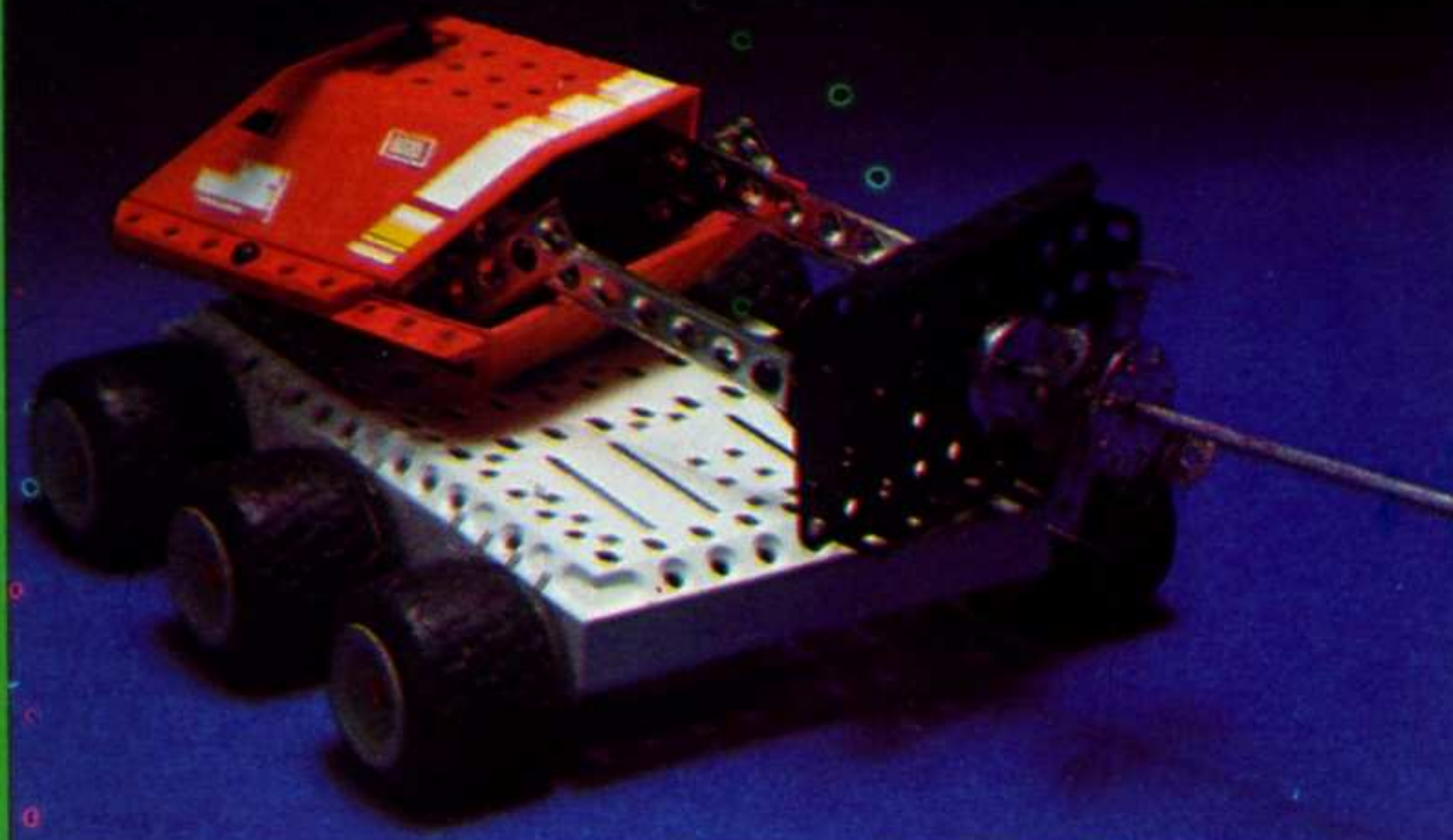



# ASTRODOZER



1

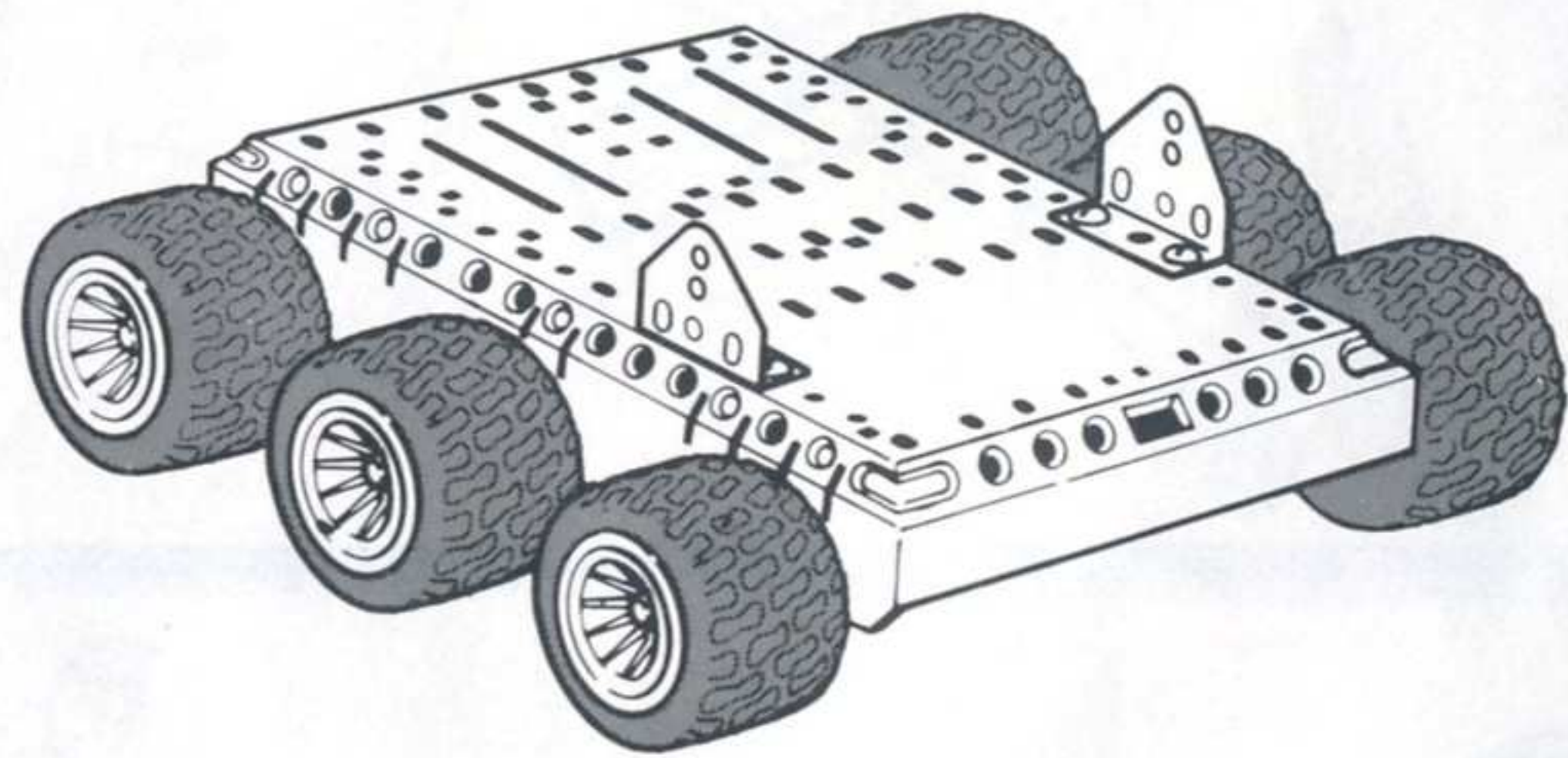

2

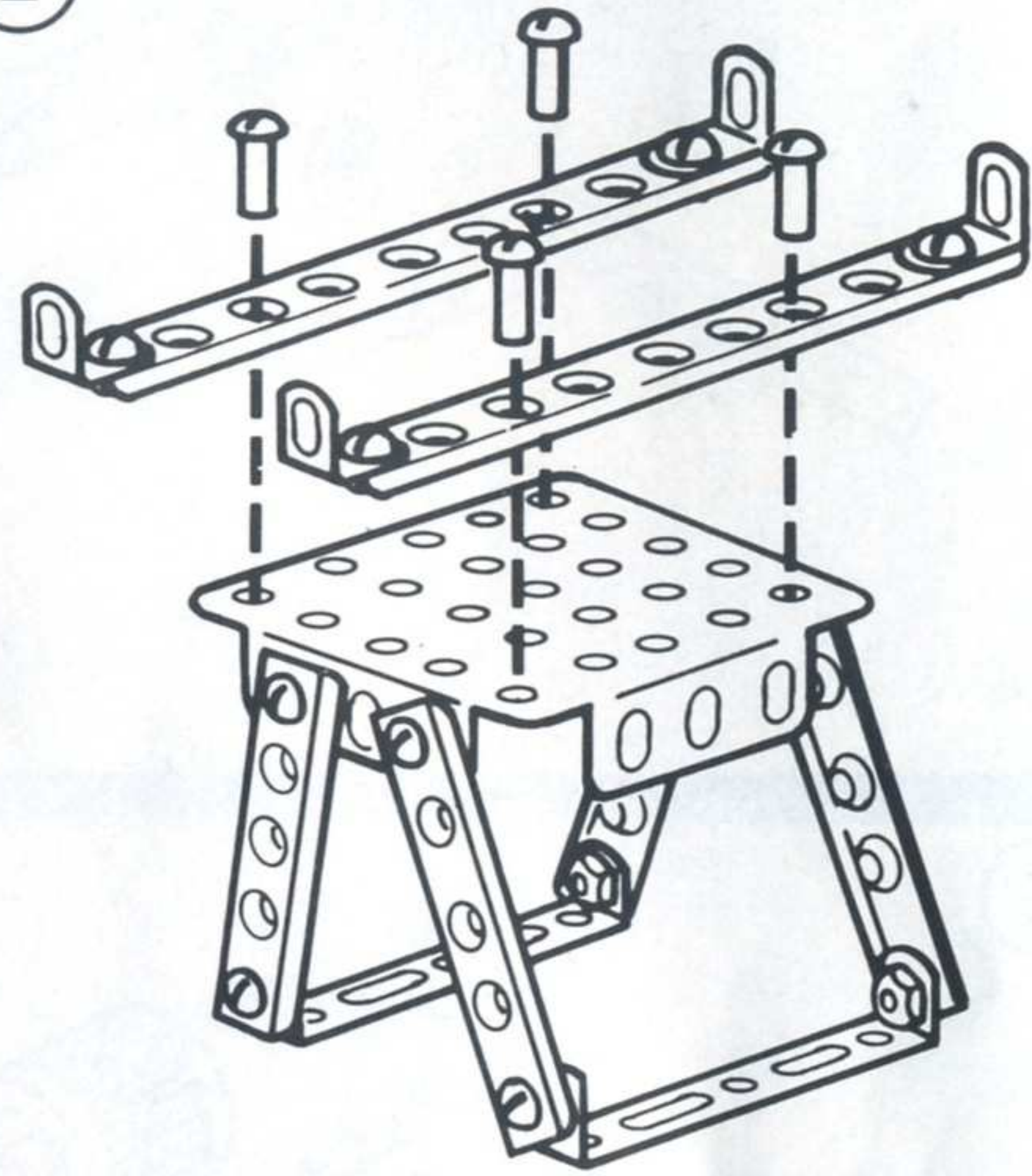

3

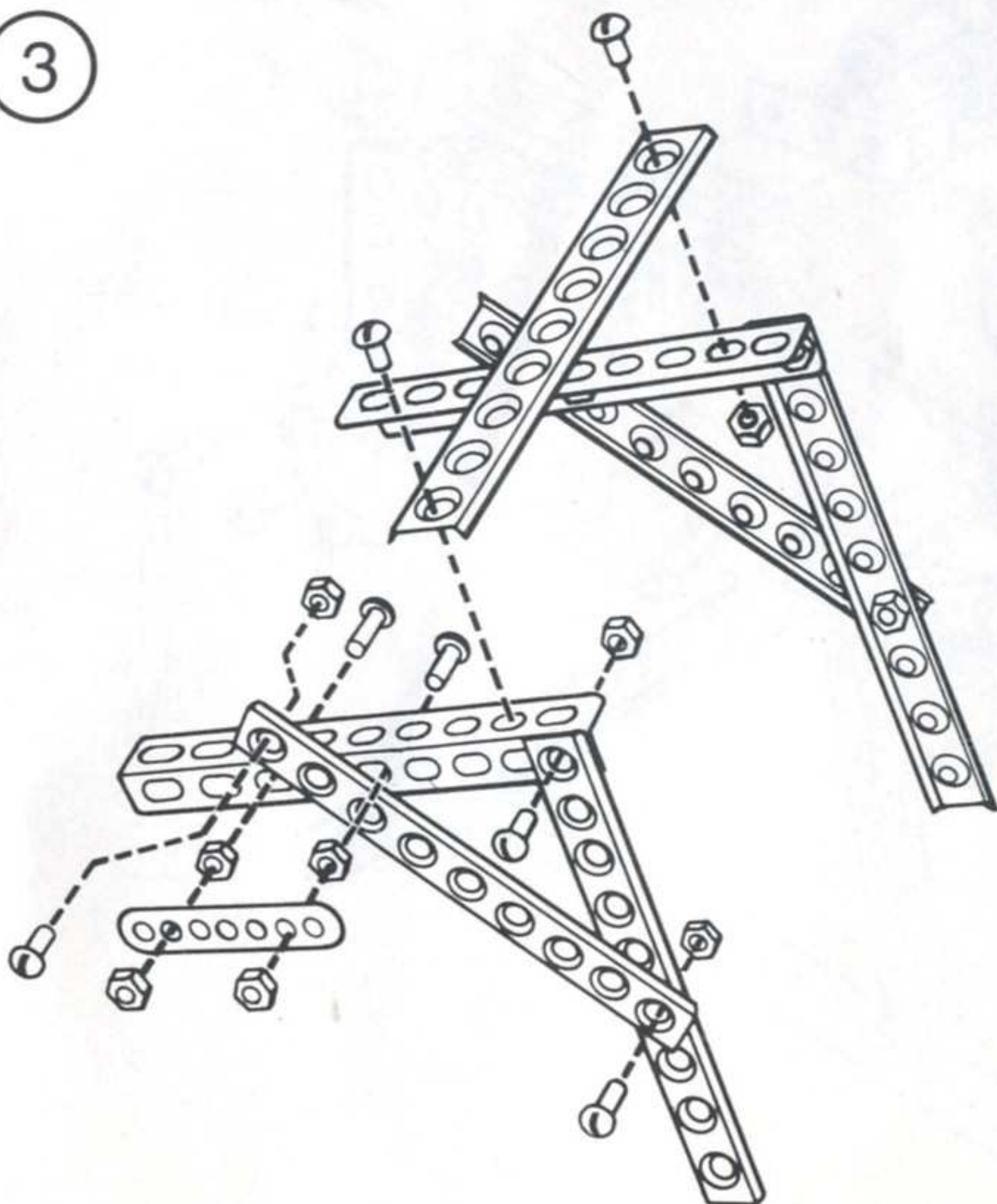

4

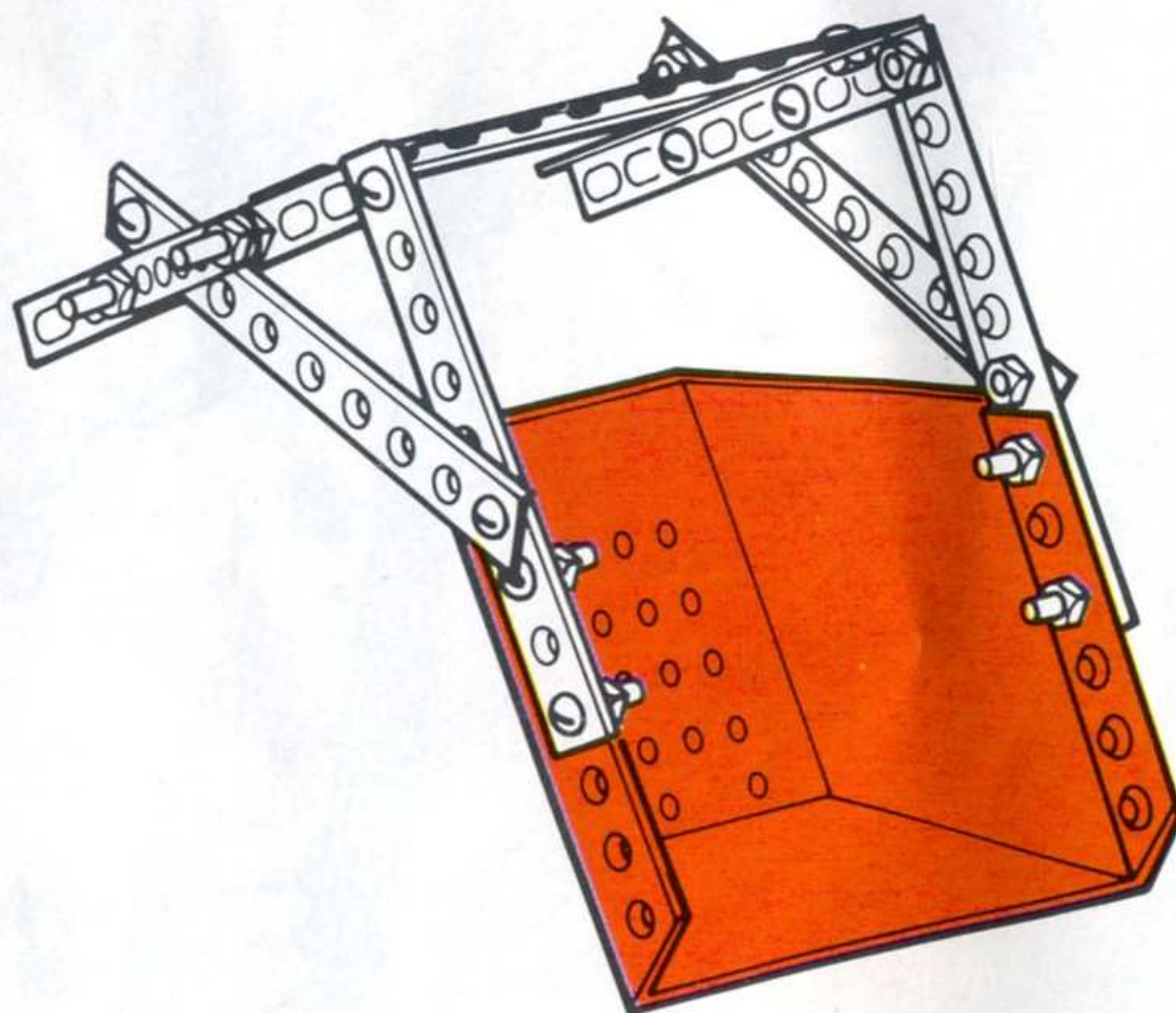

5

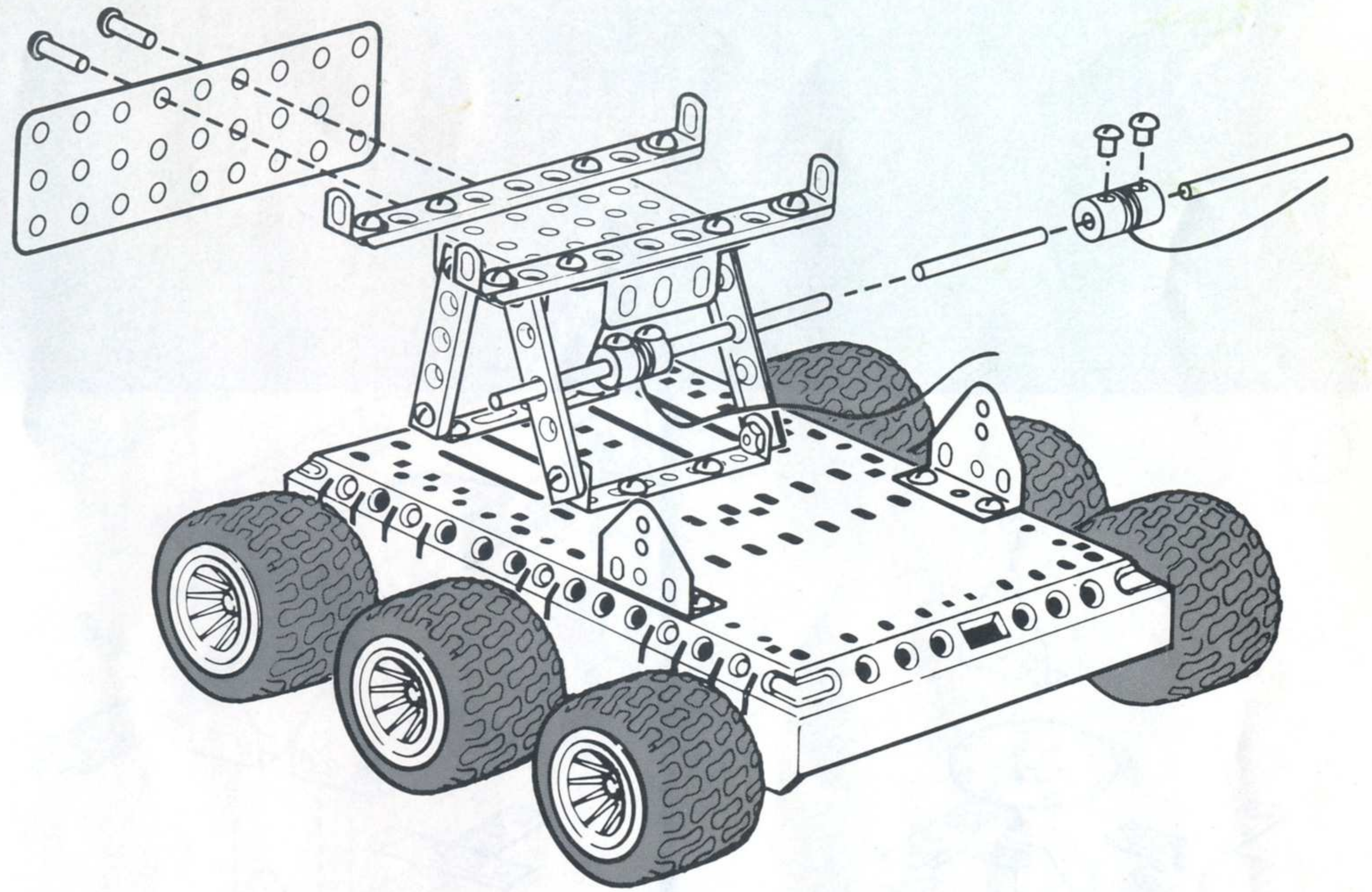

6

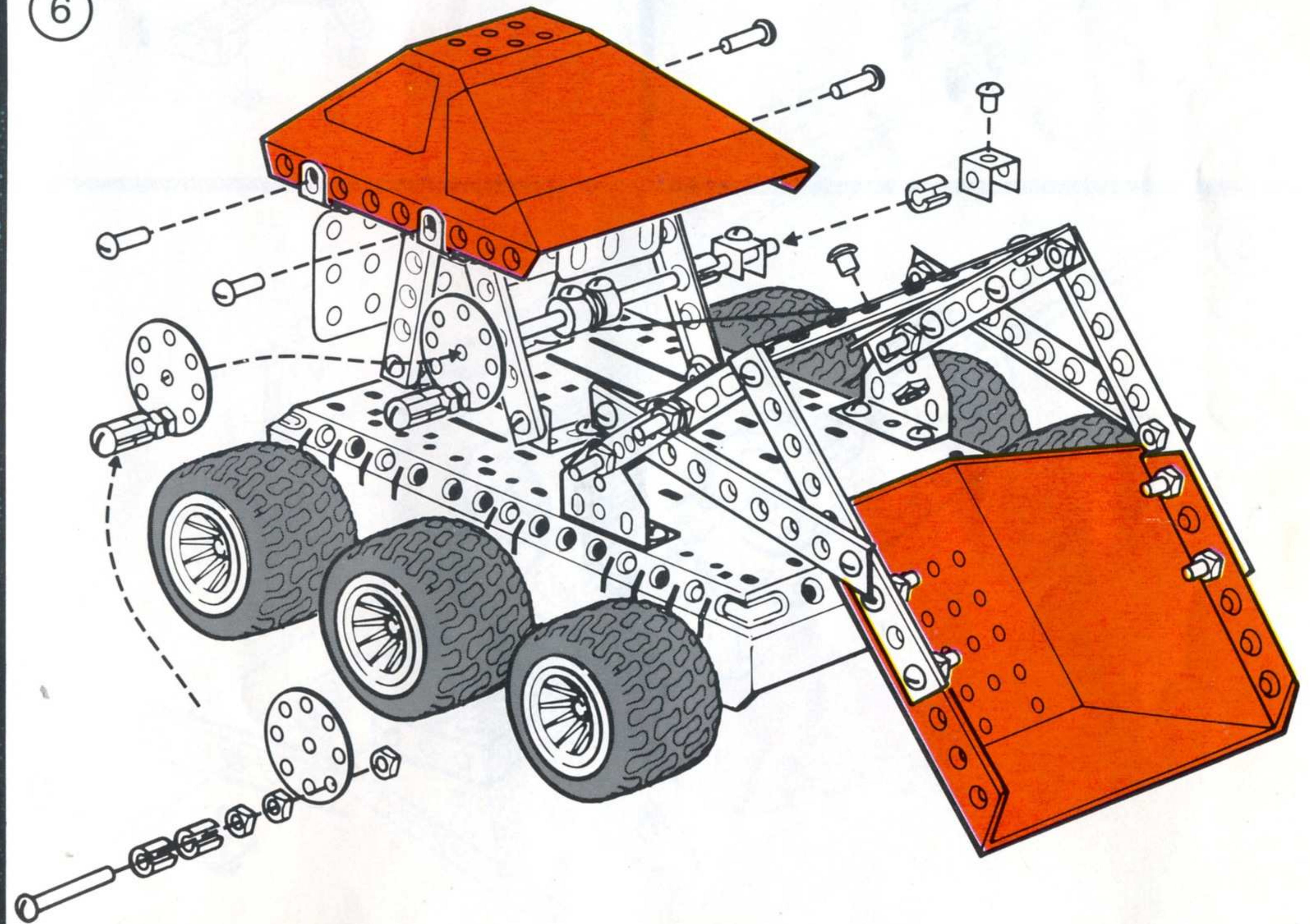



# HELICOPTER

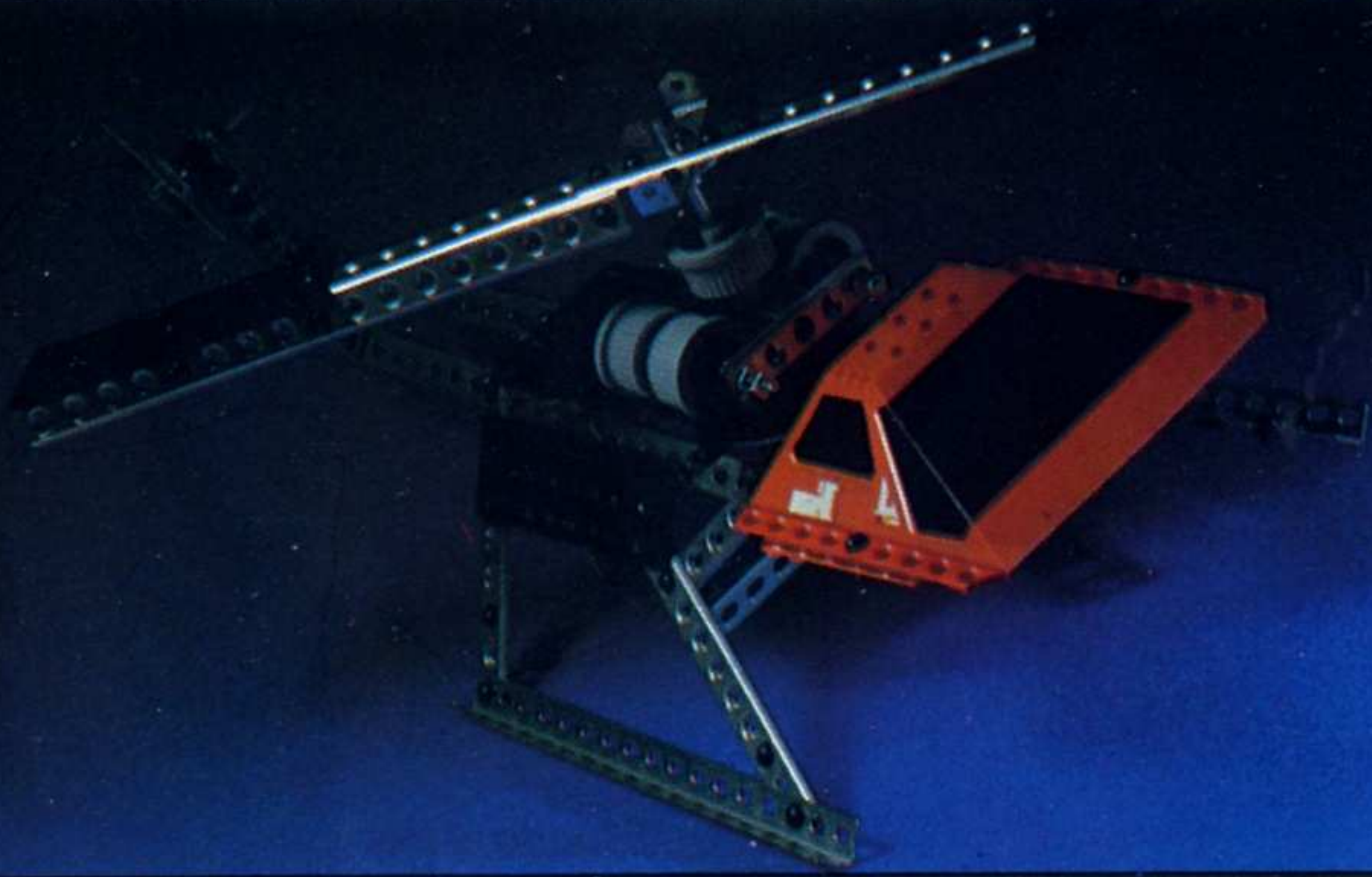

1

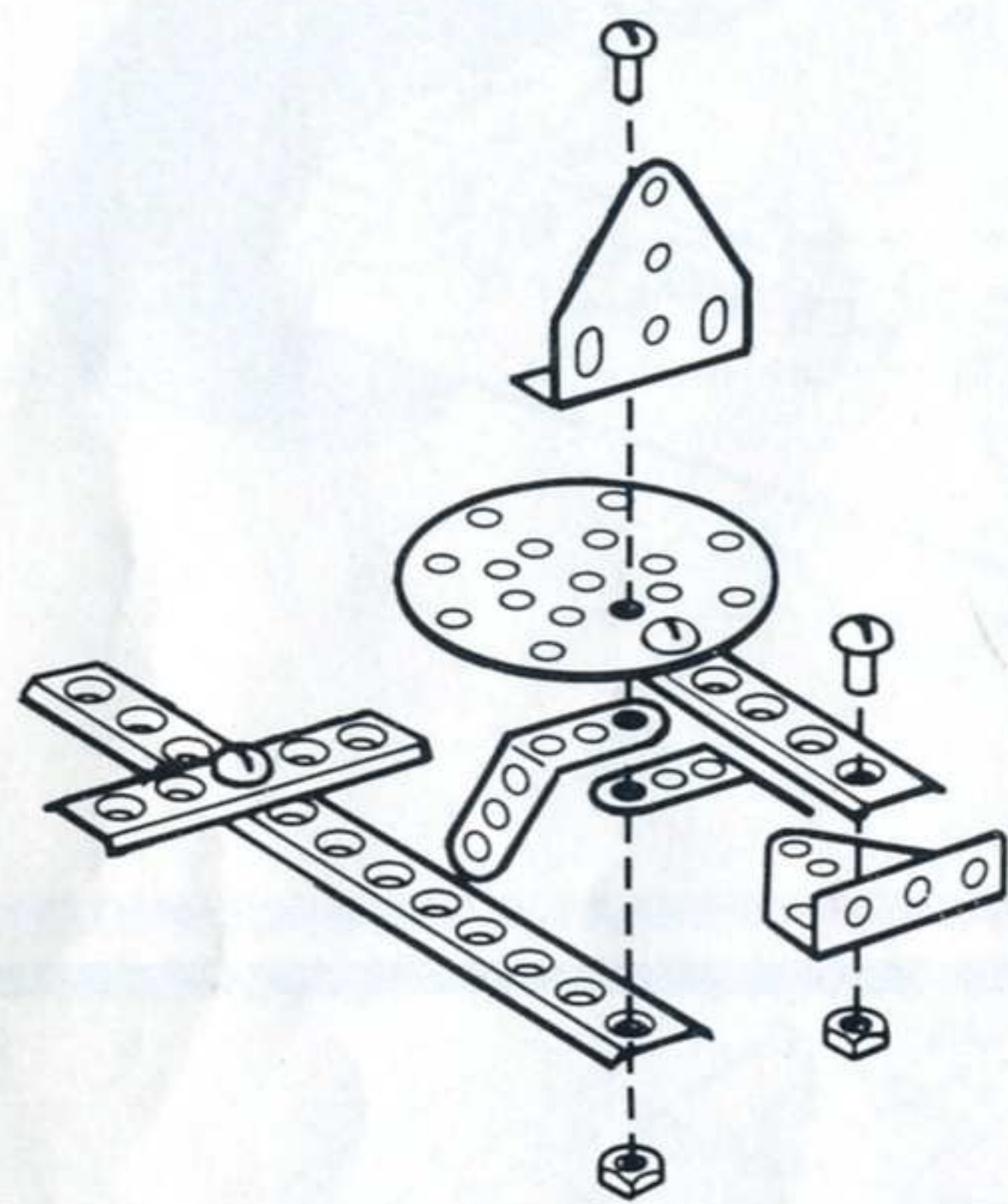

2

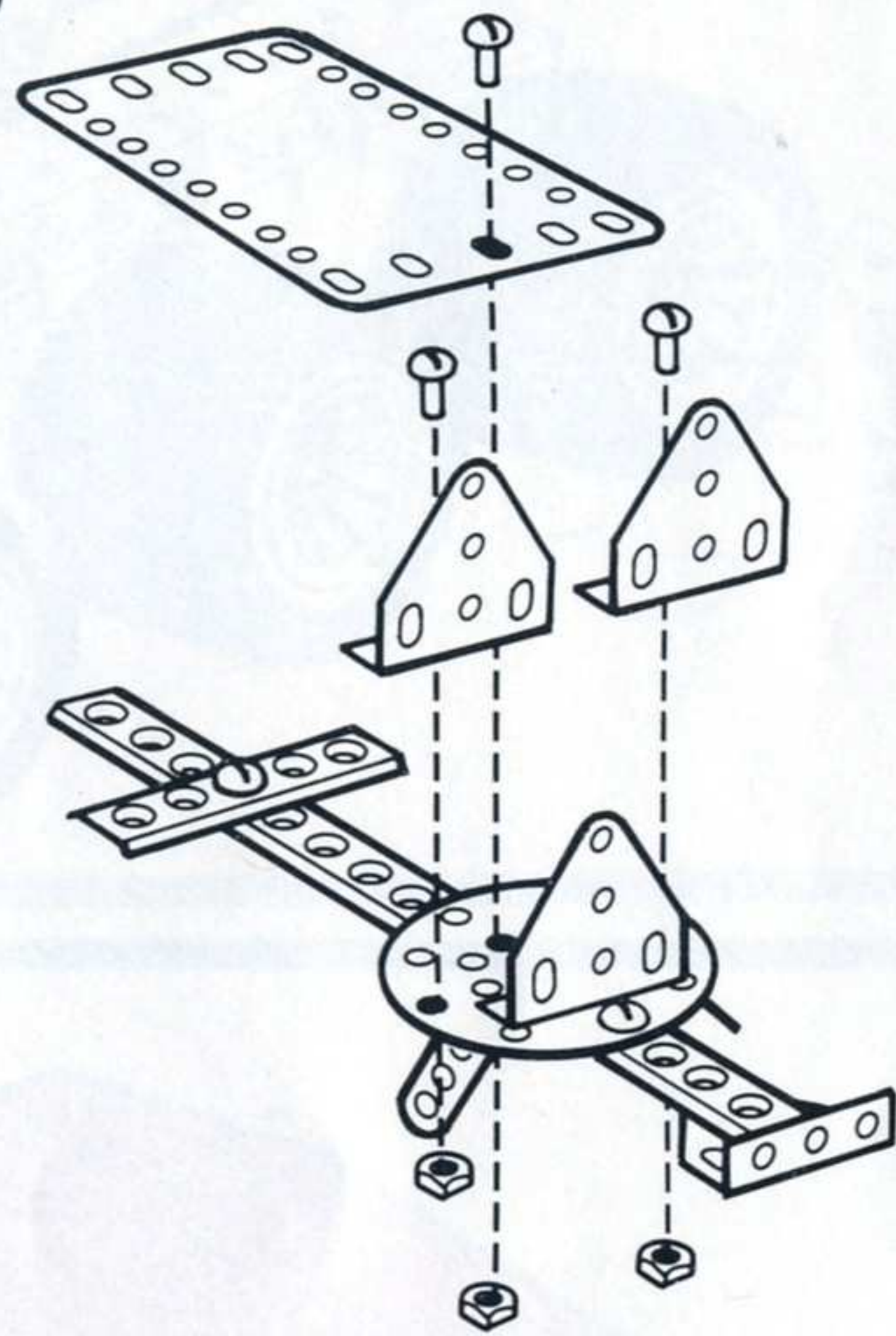

3

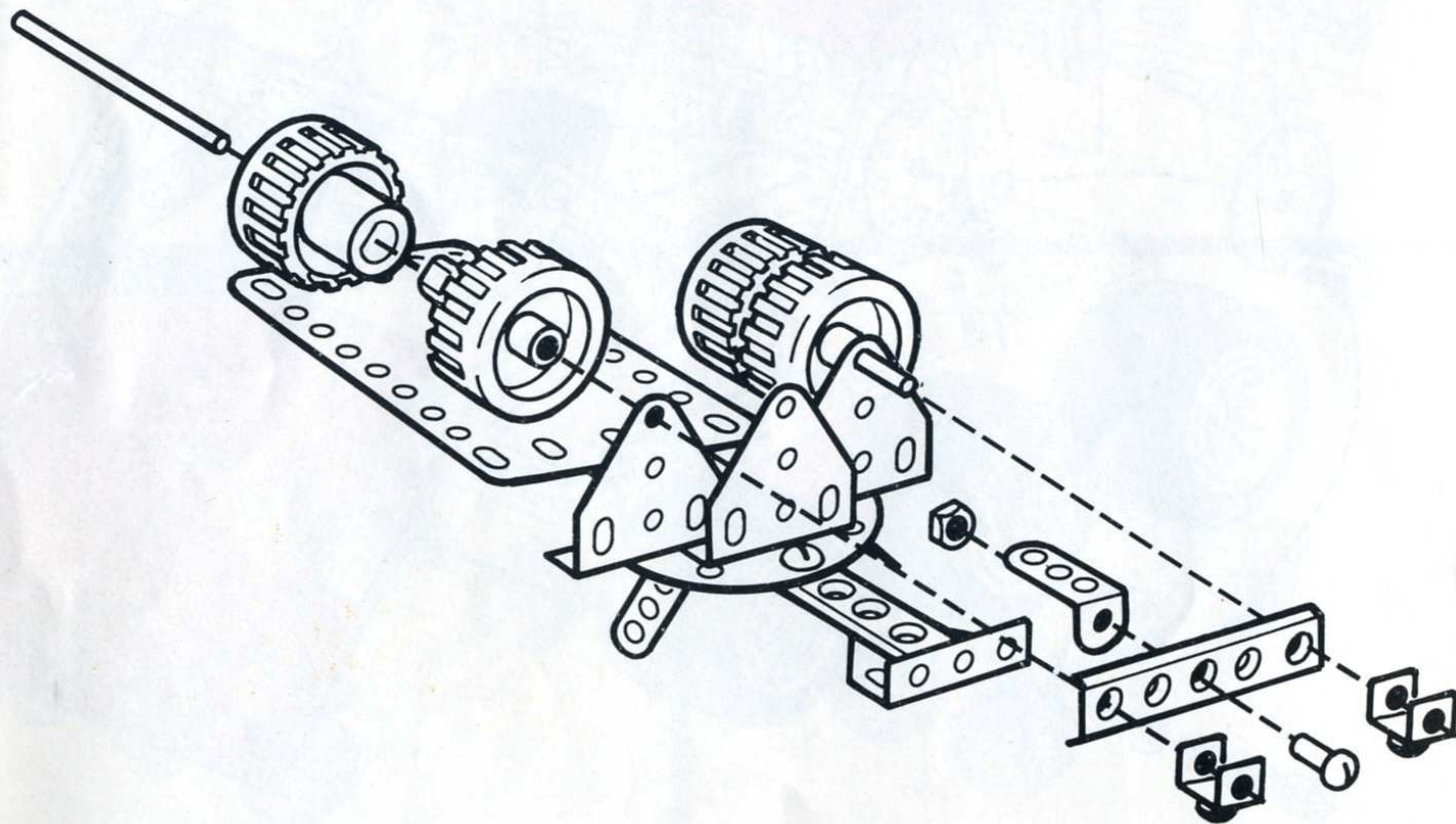

4

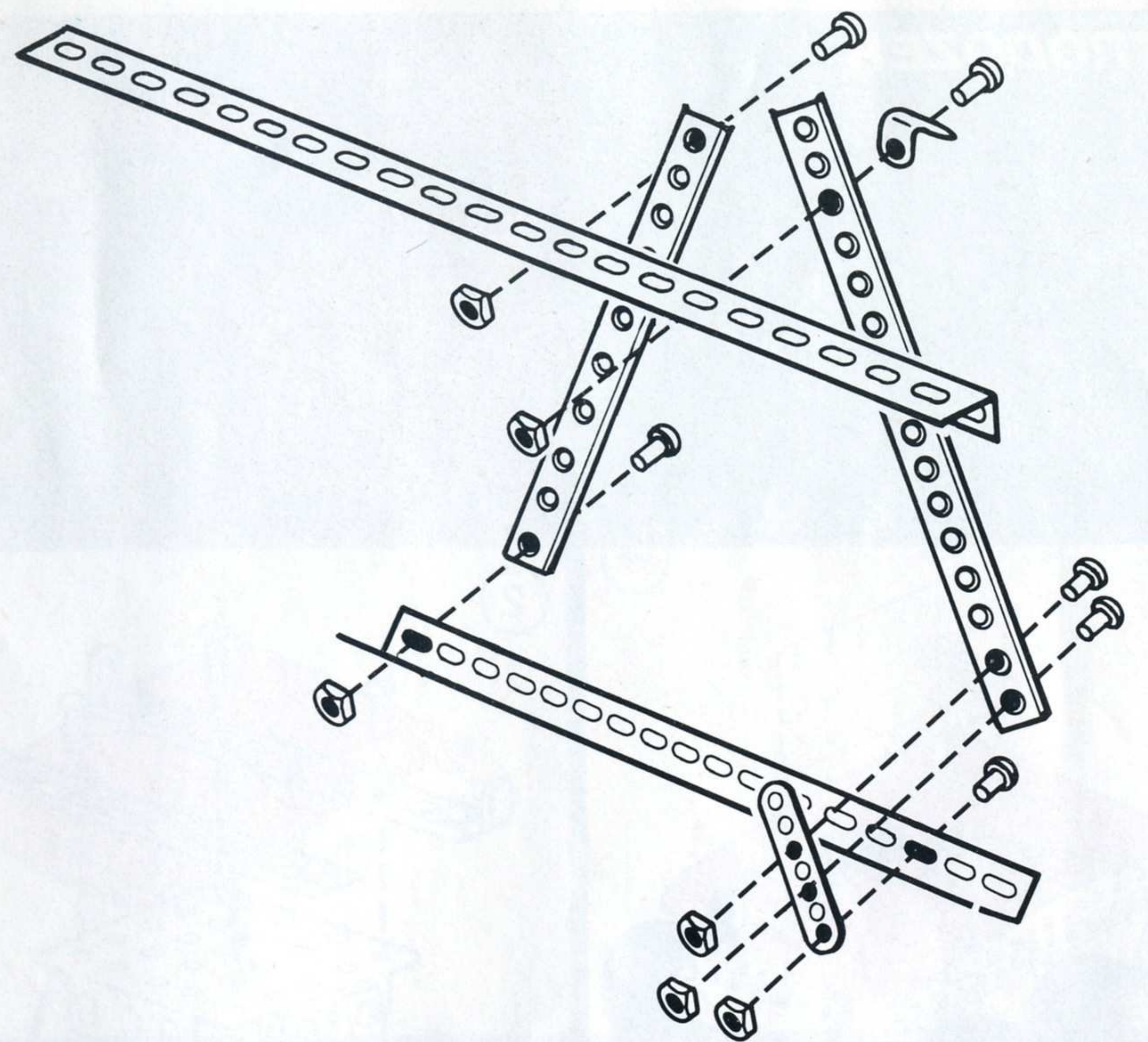

5

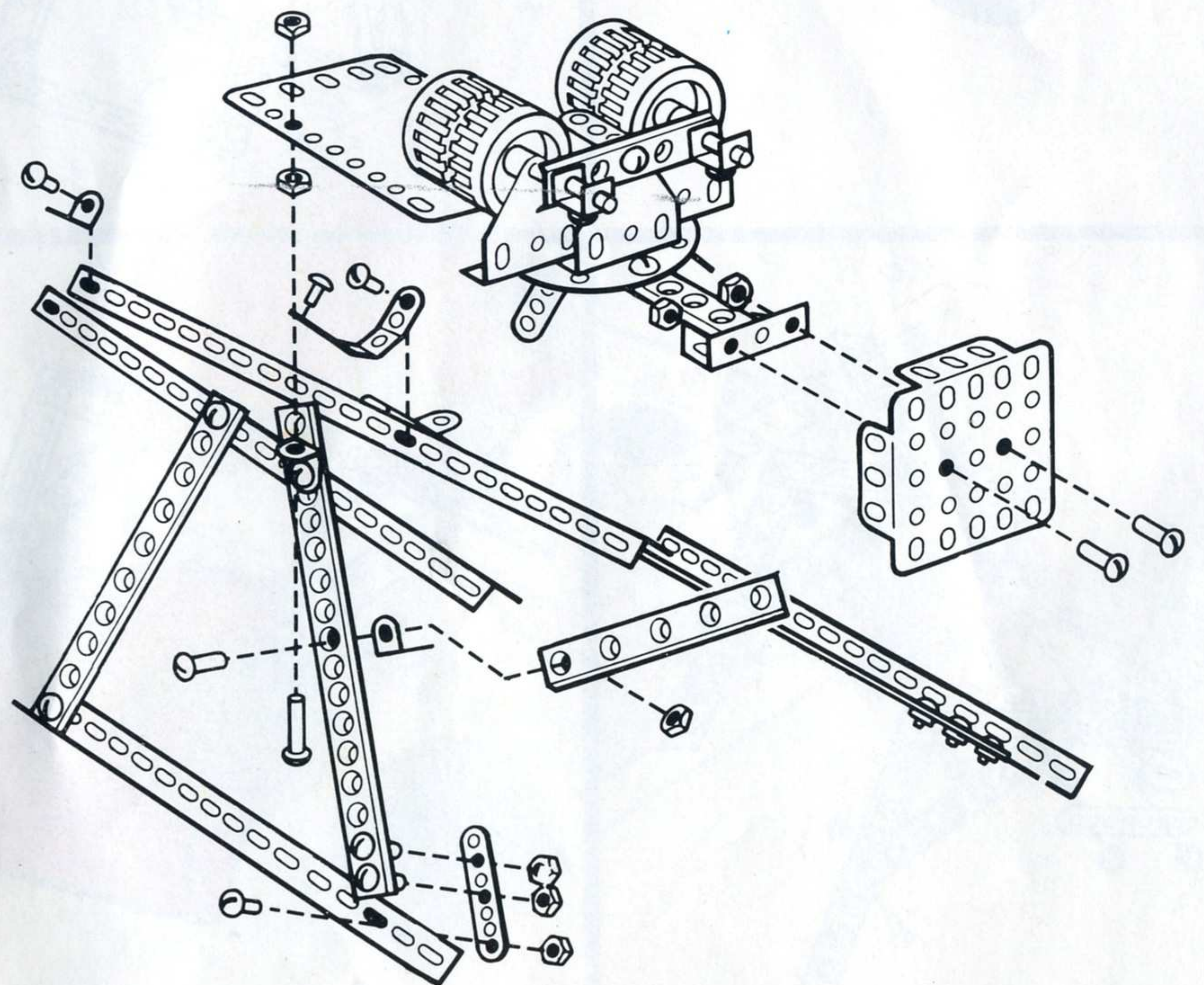



6

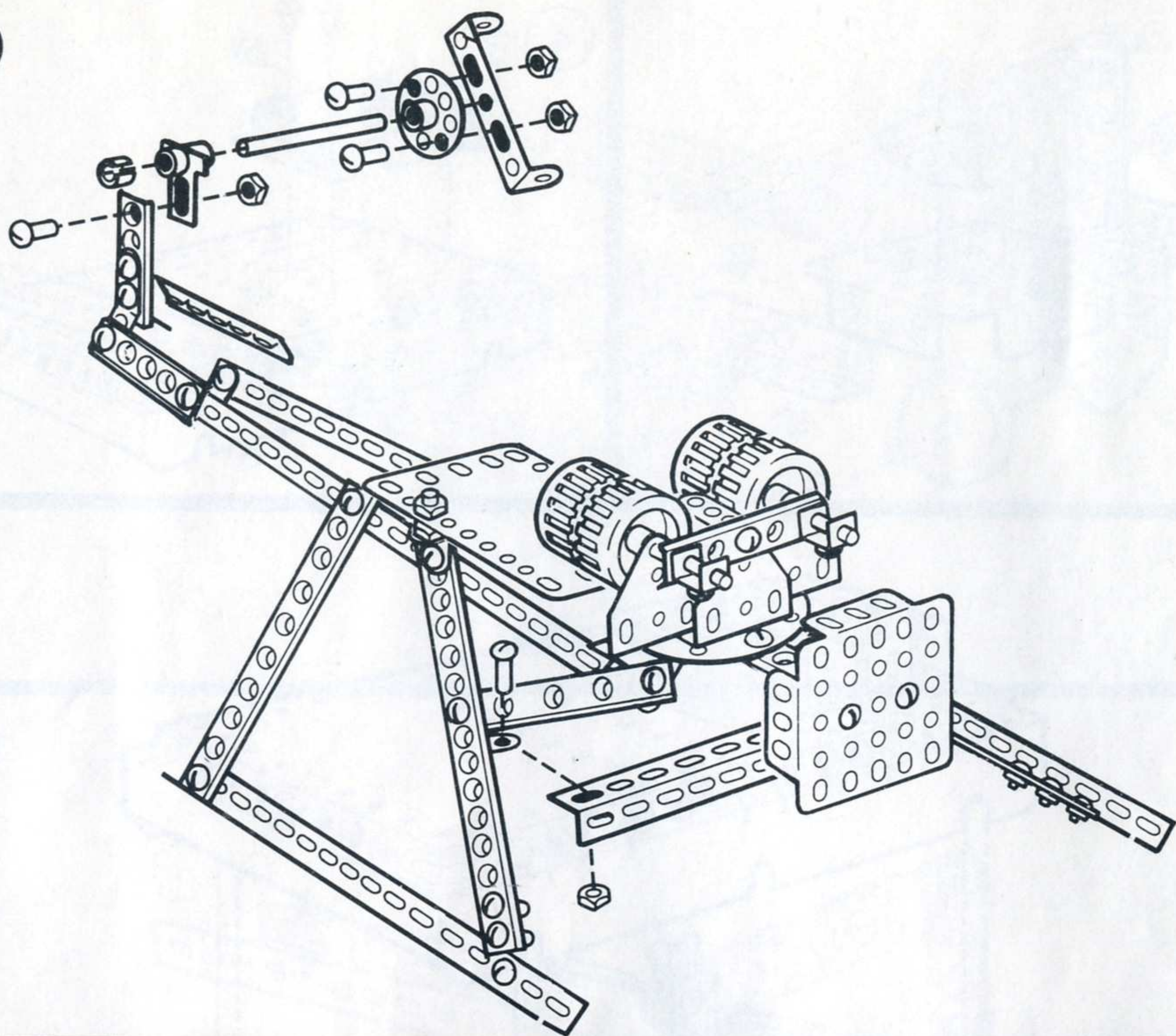

8

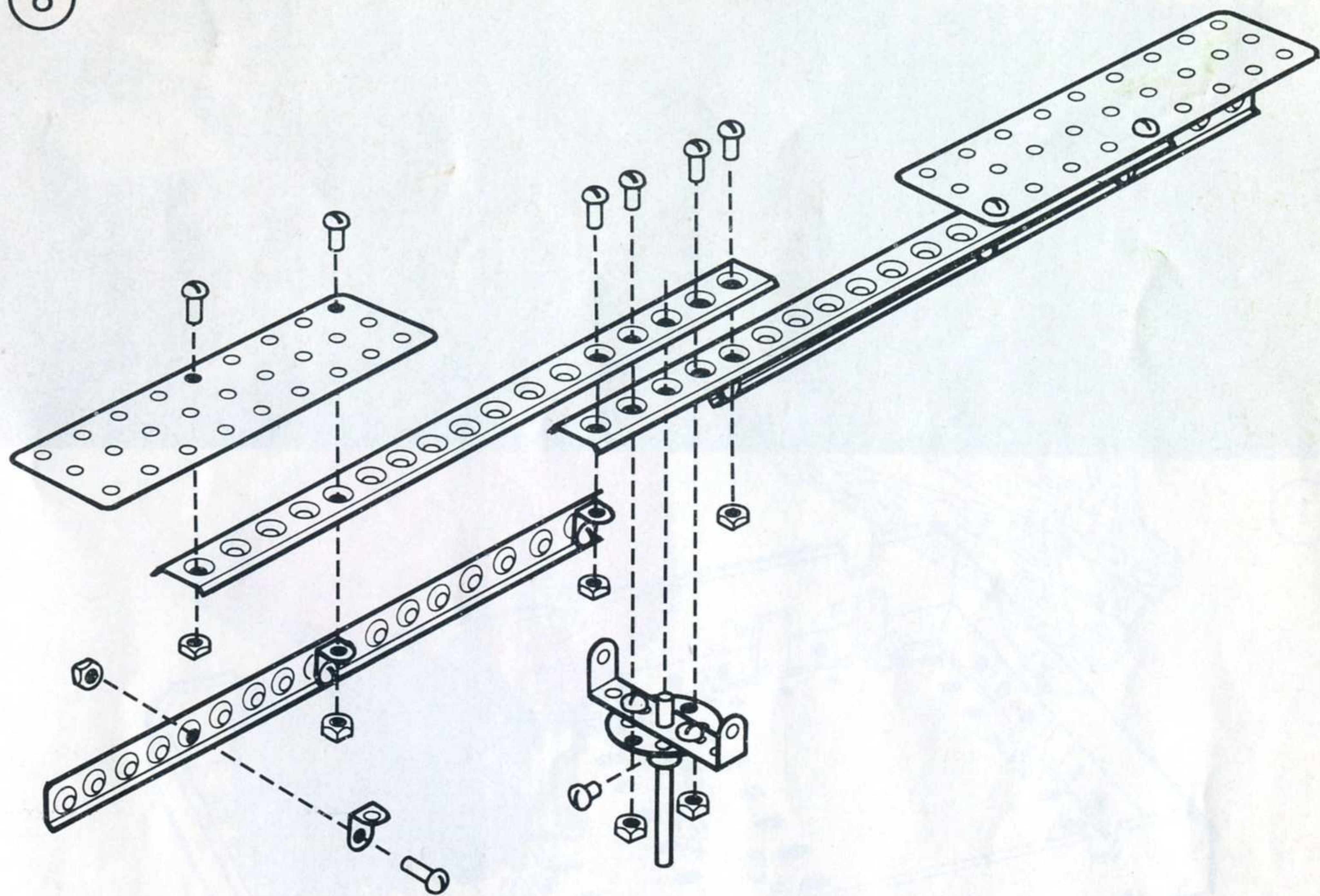

7

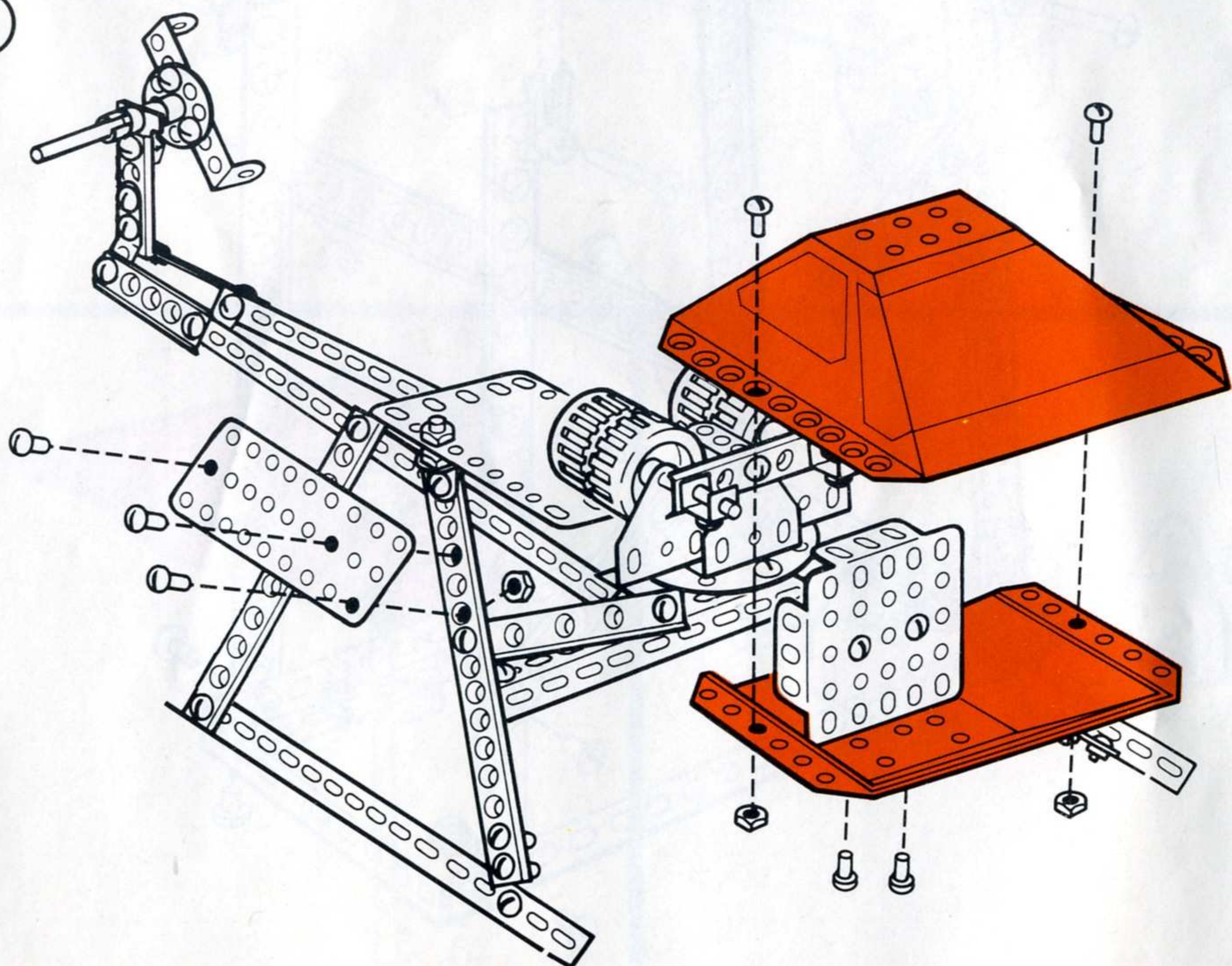

9

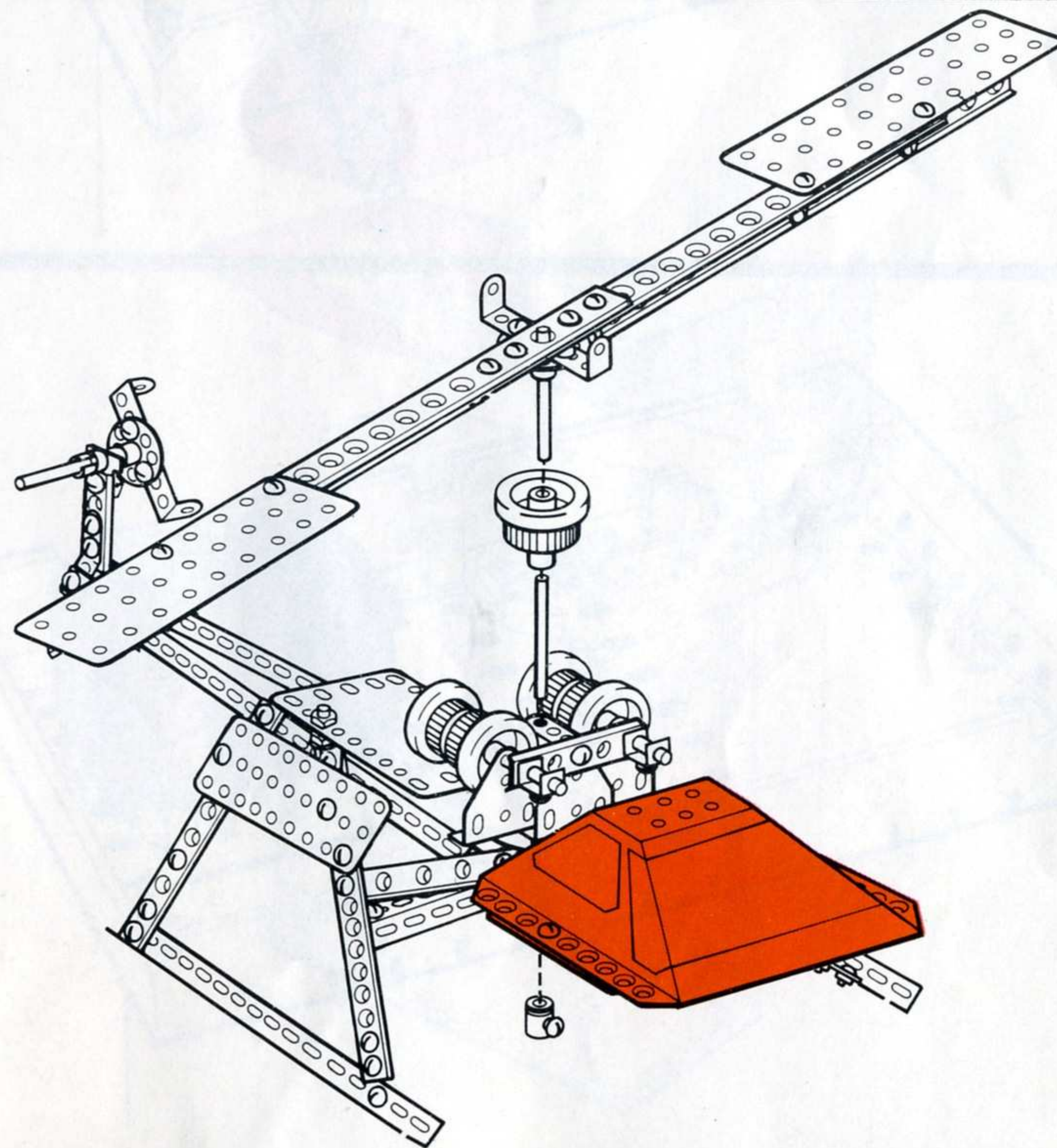



# TOWER CRANE



1

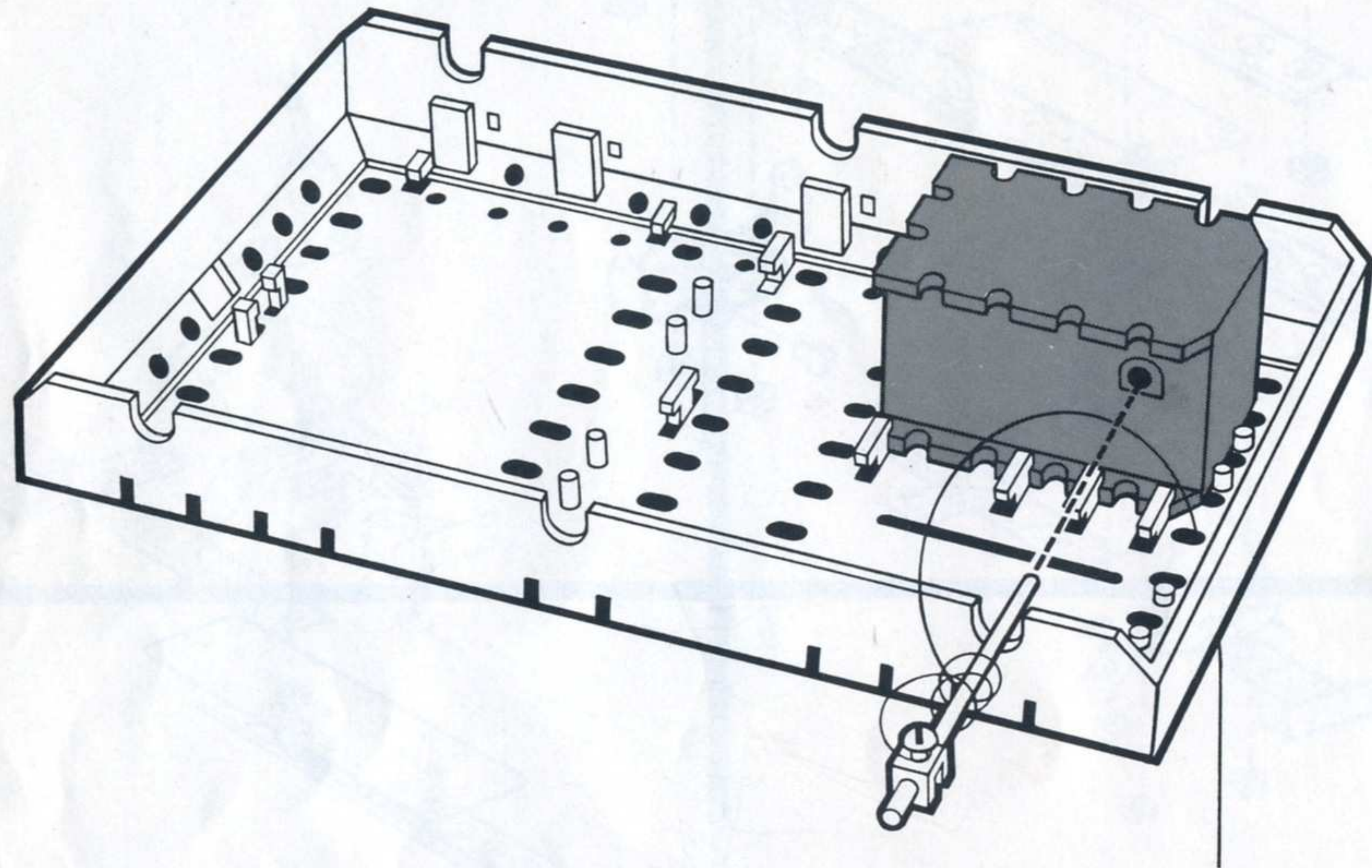

2

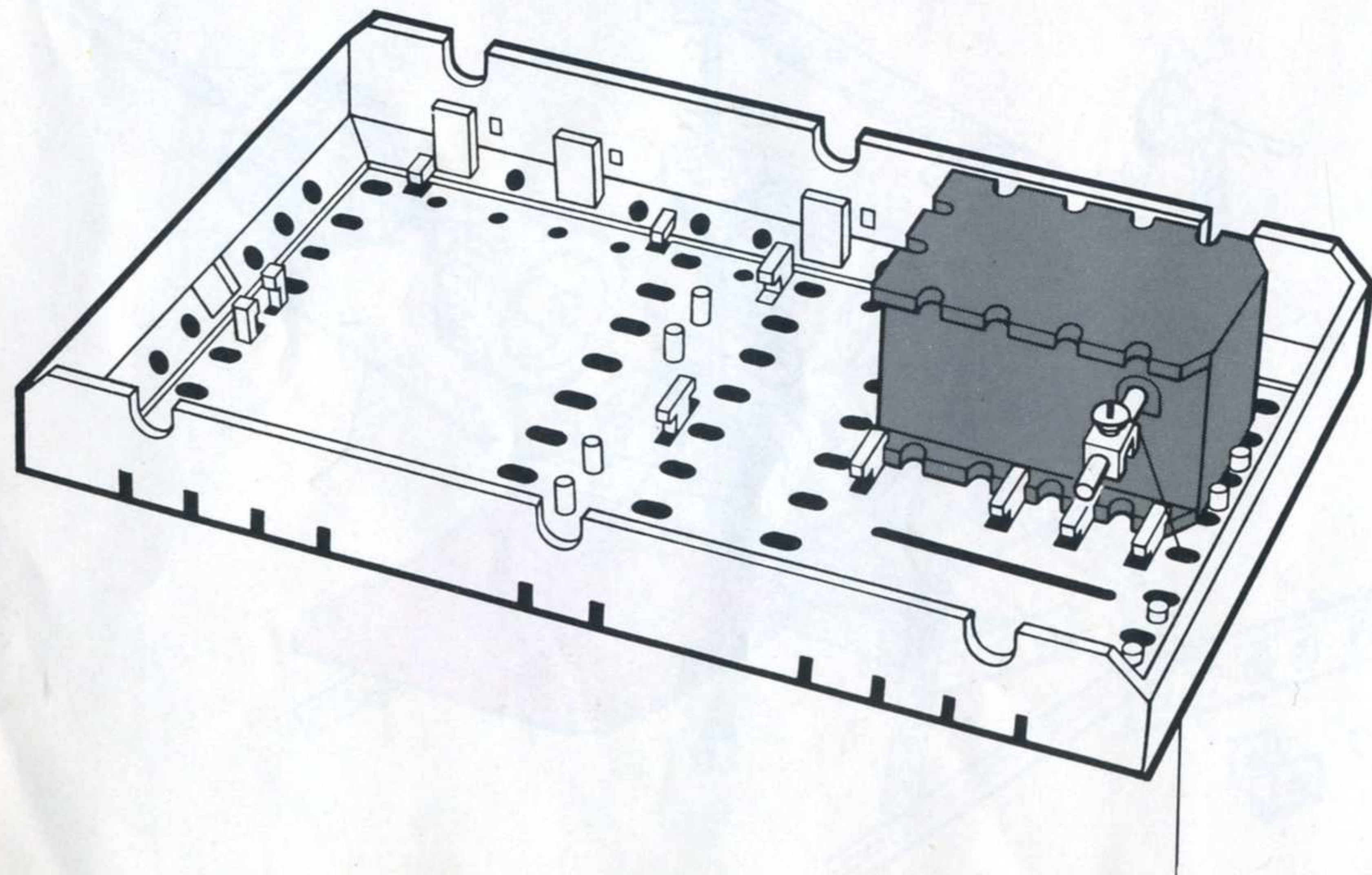

3

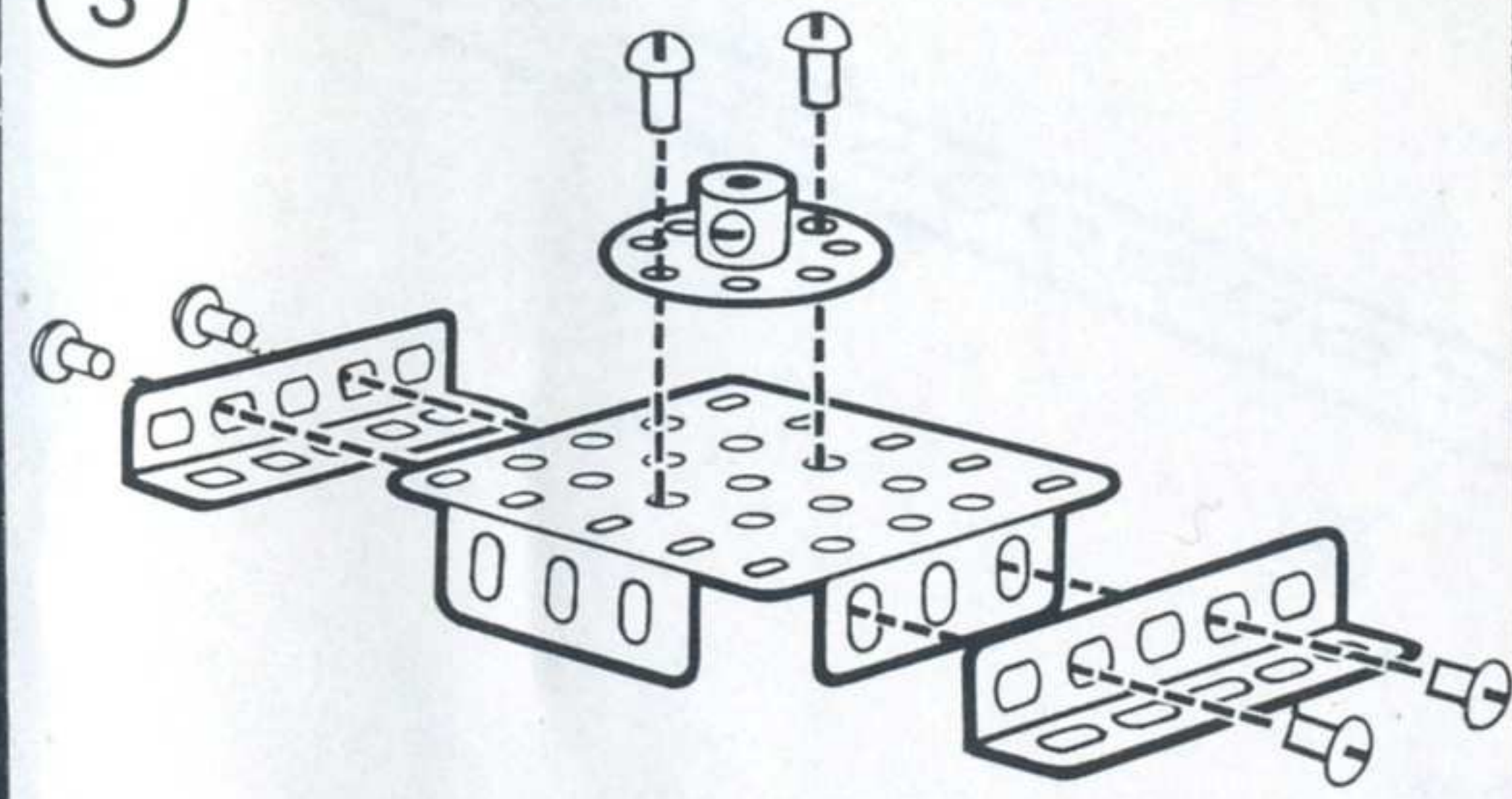

4

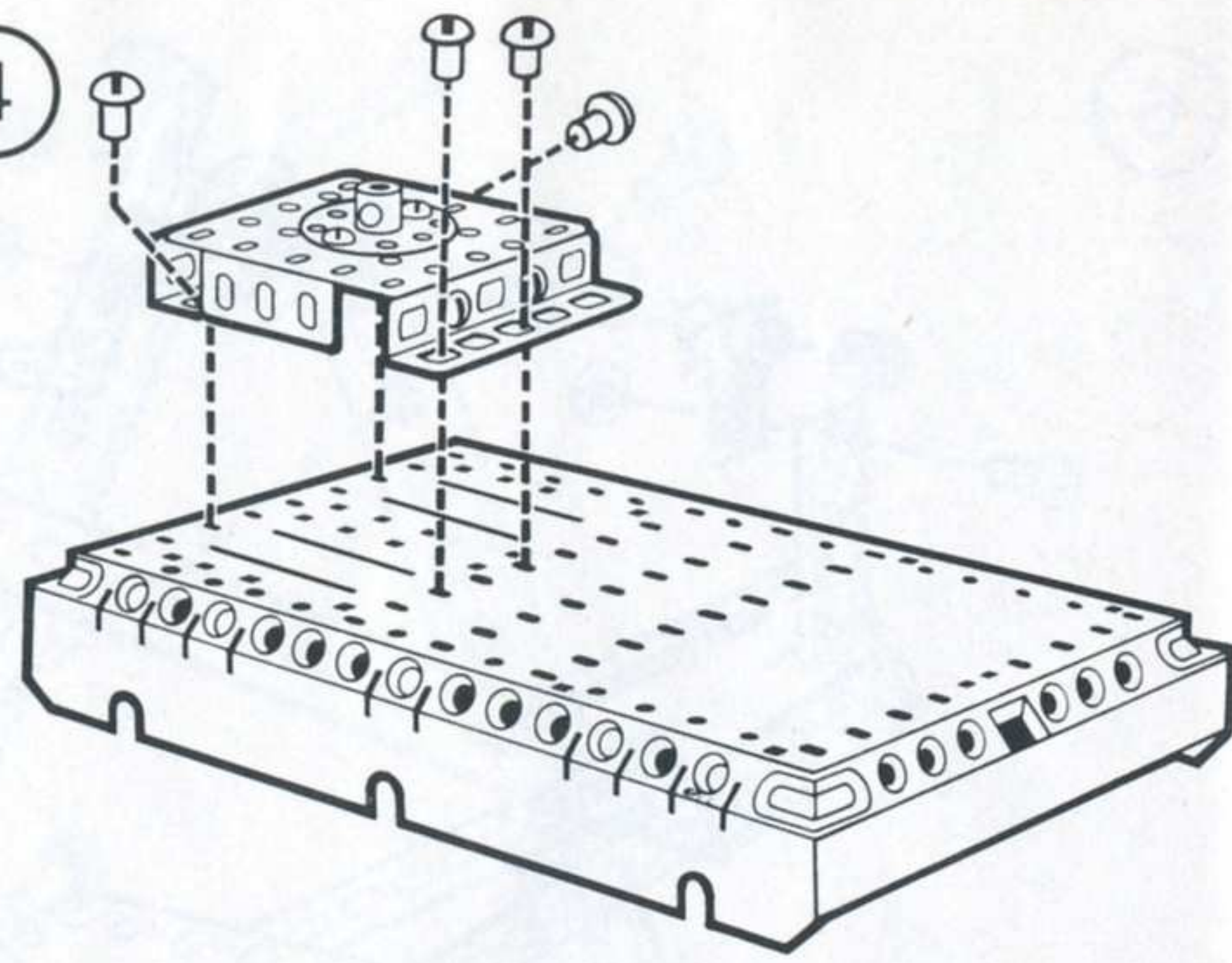

5

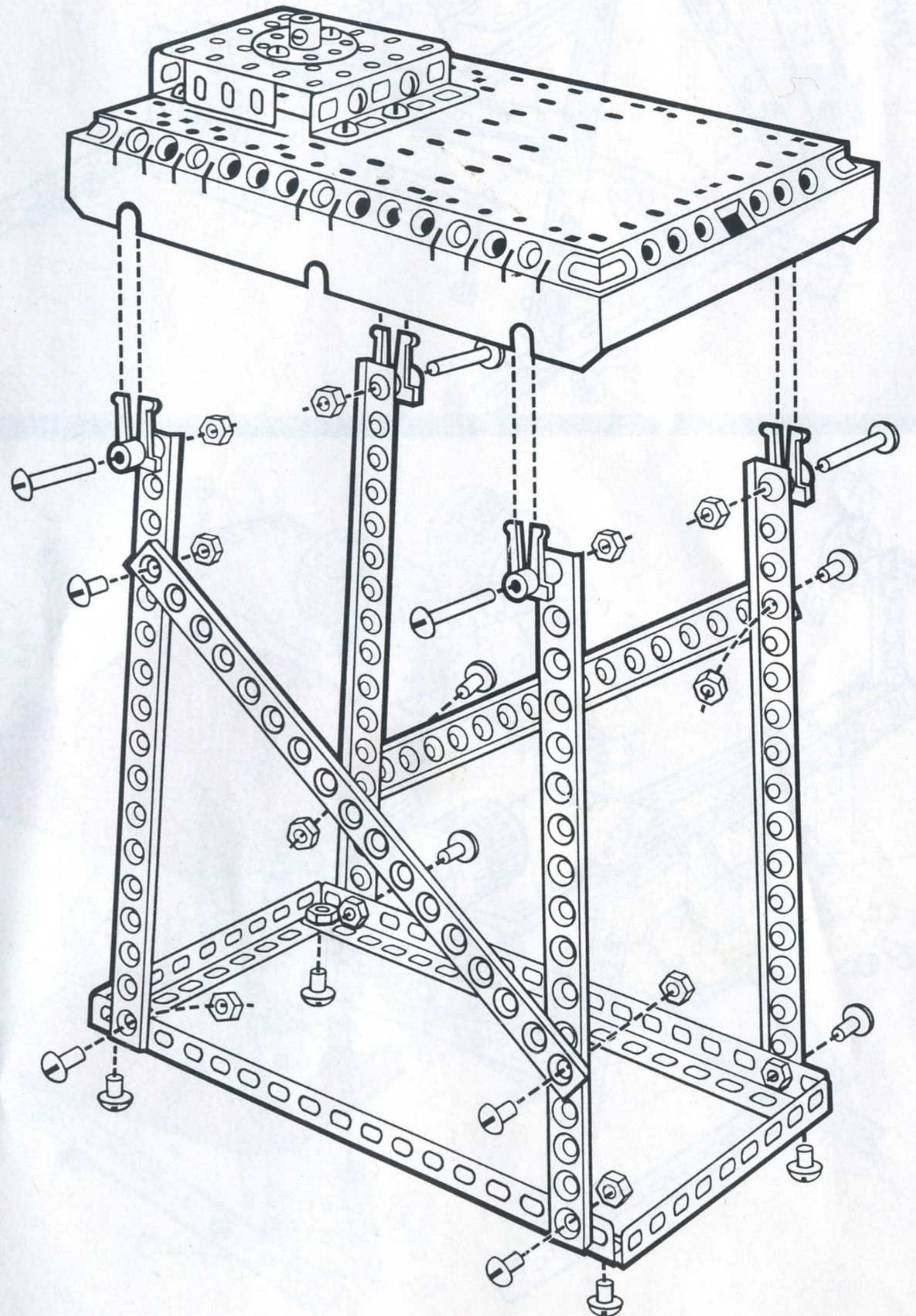



6

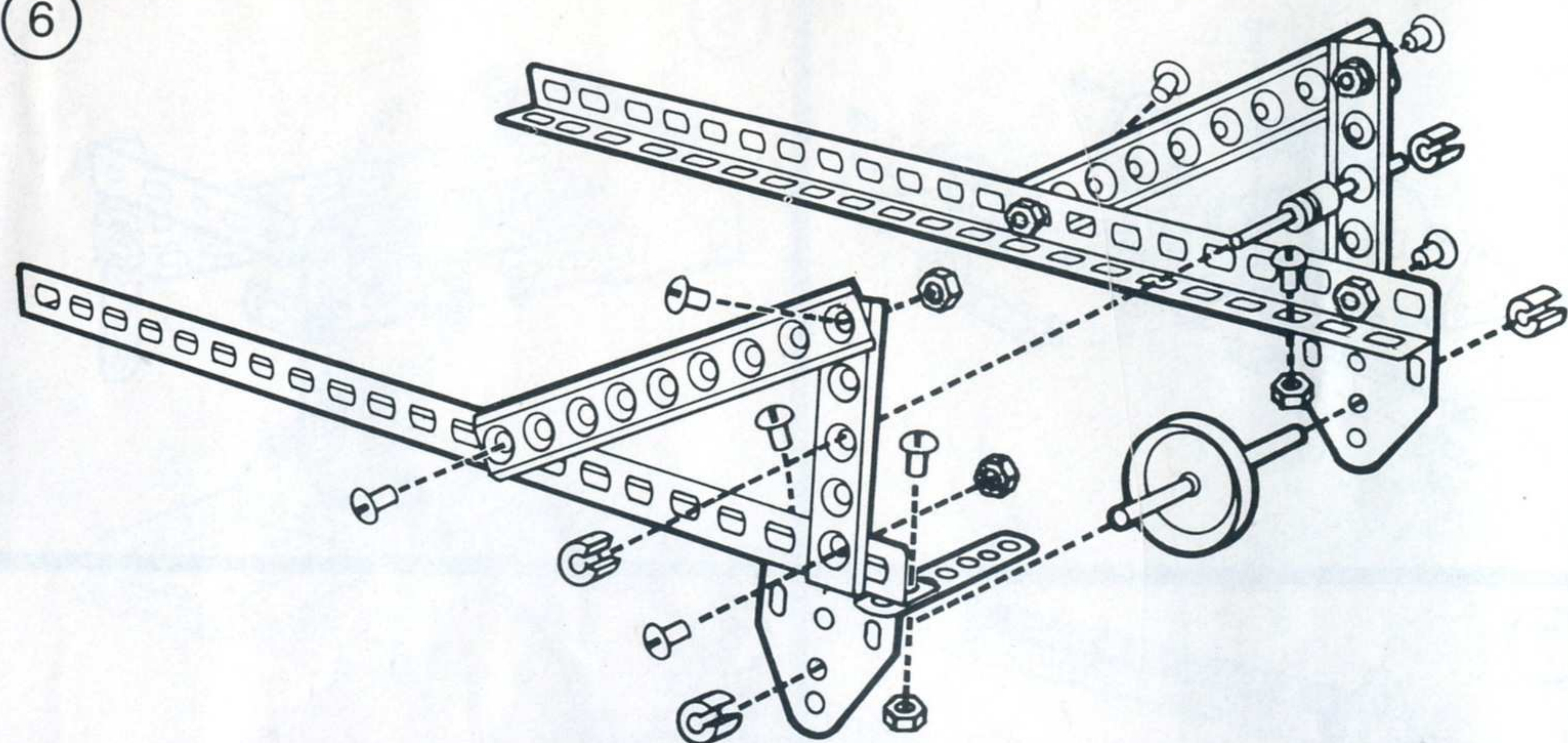

7

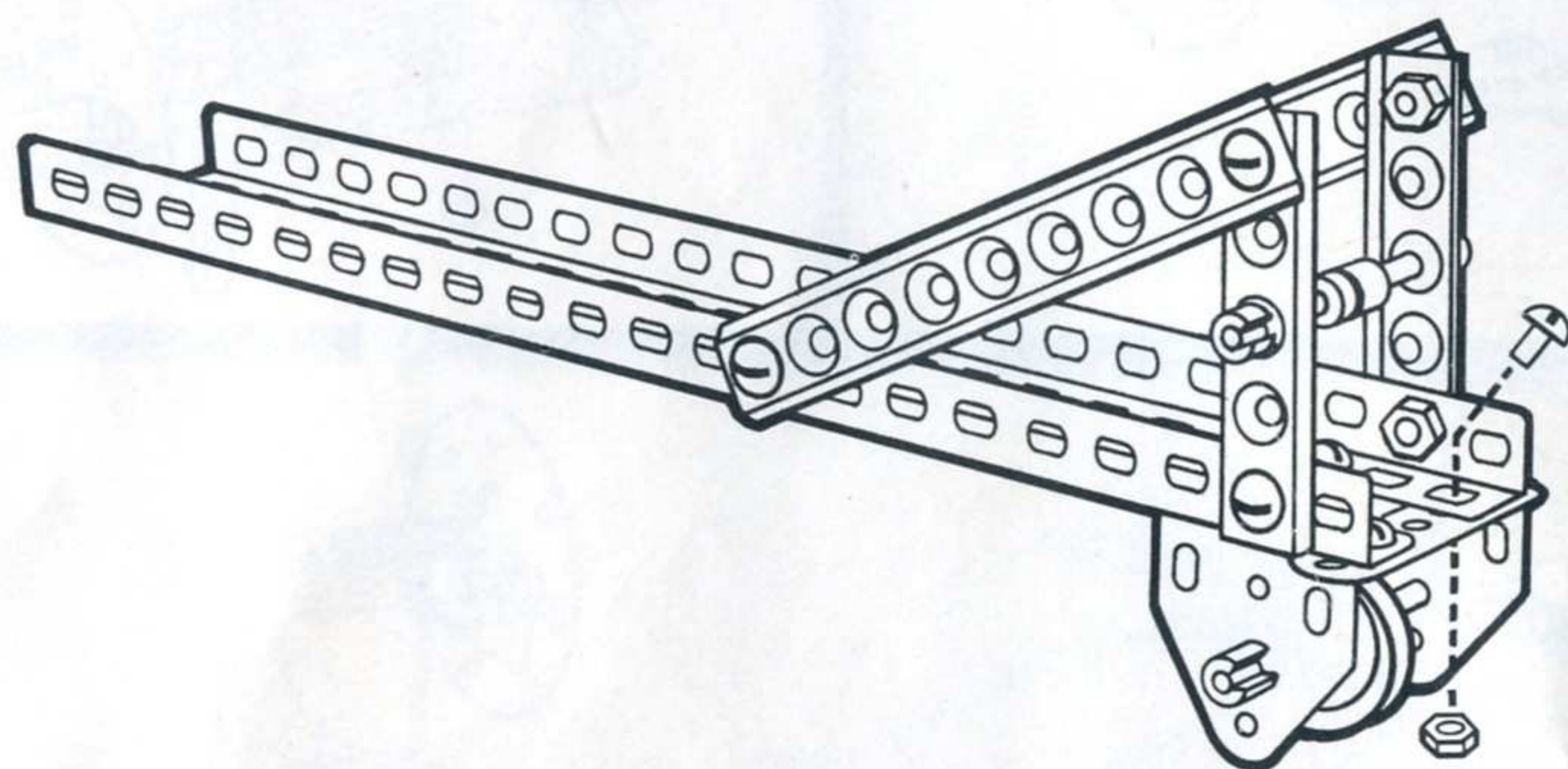

8

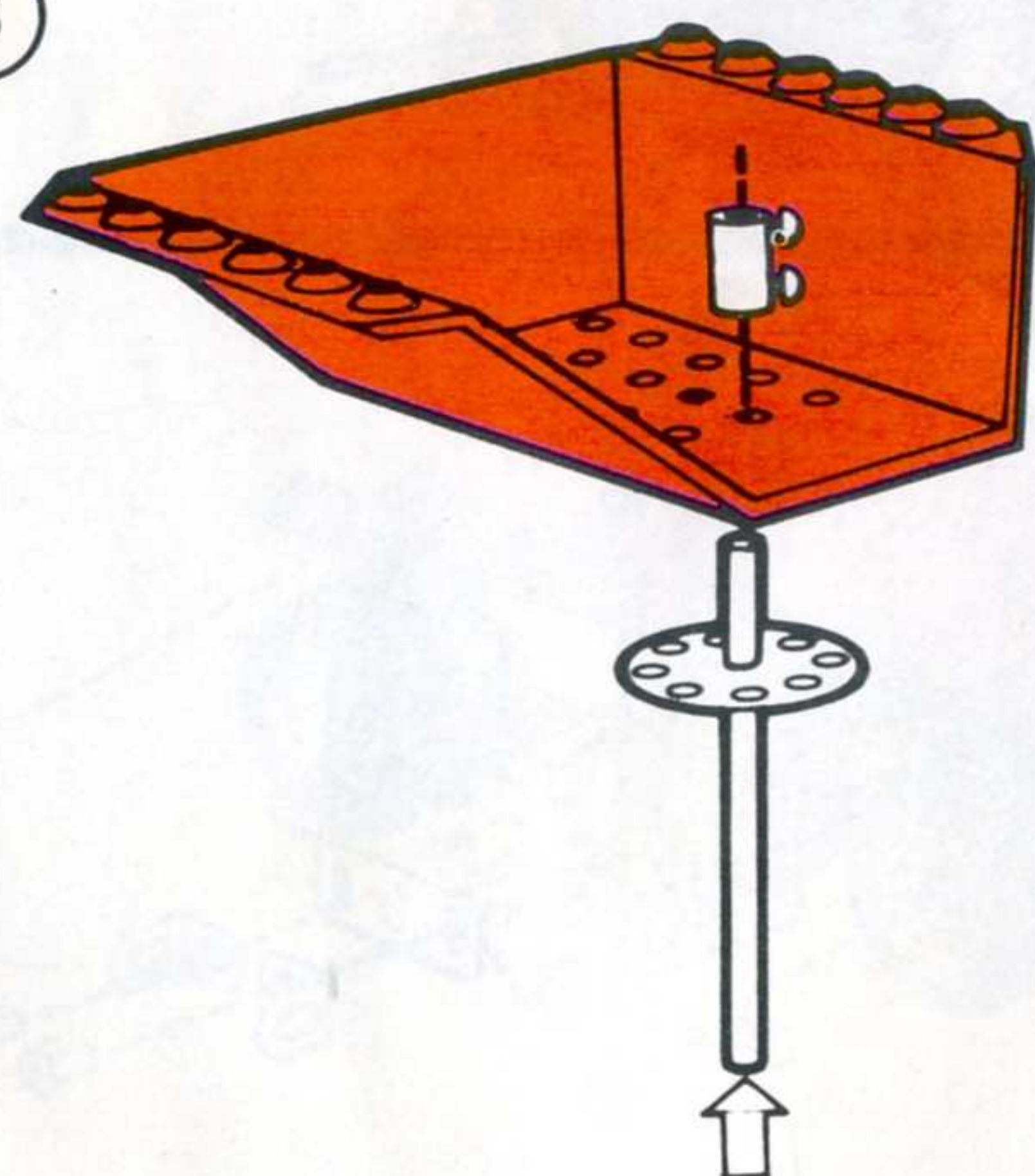

9

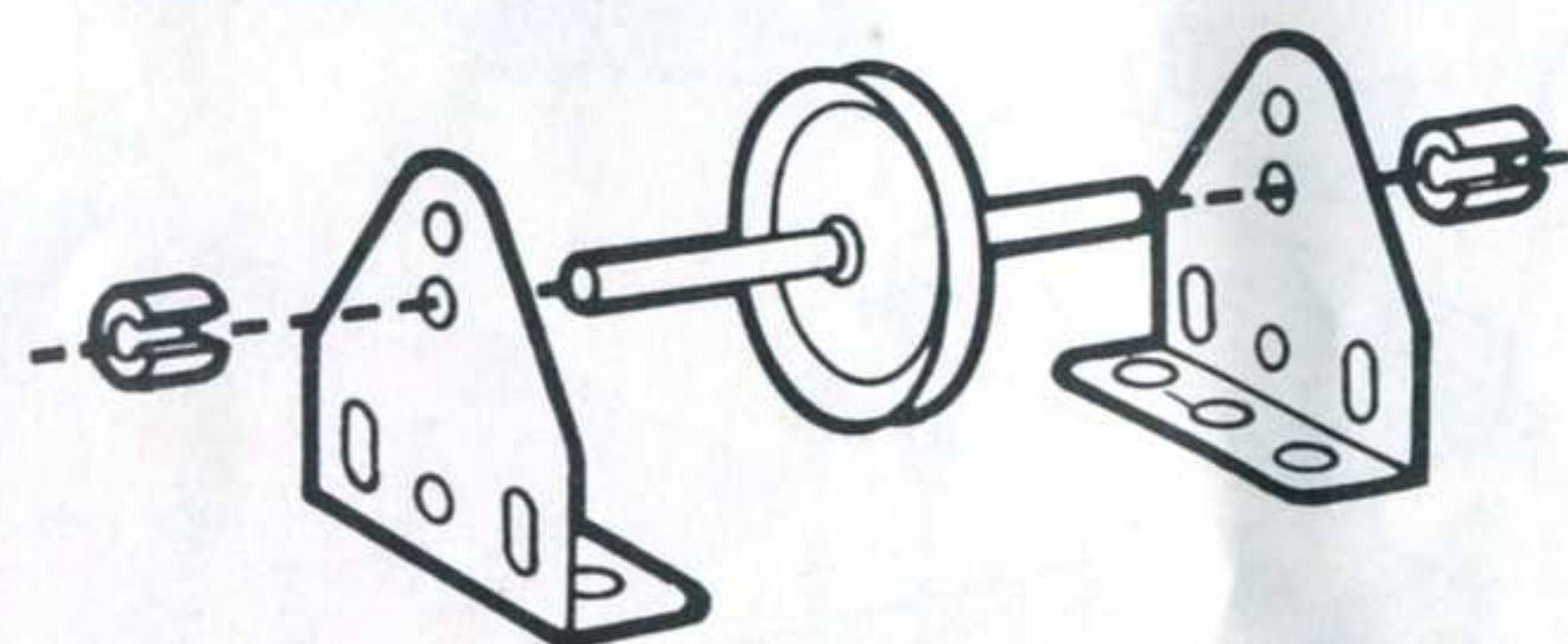

10

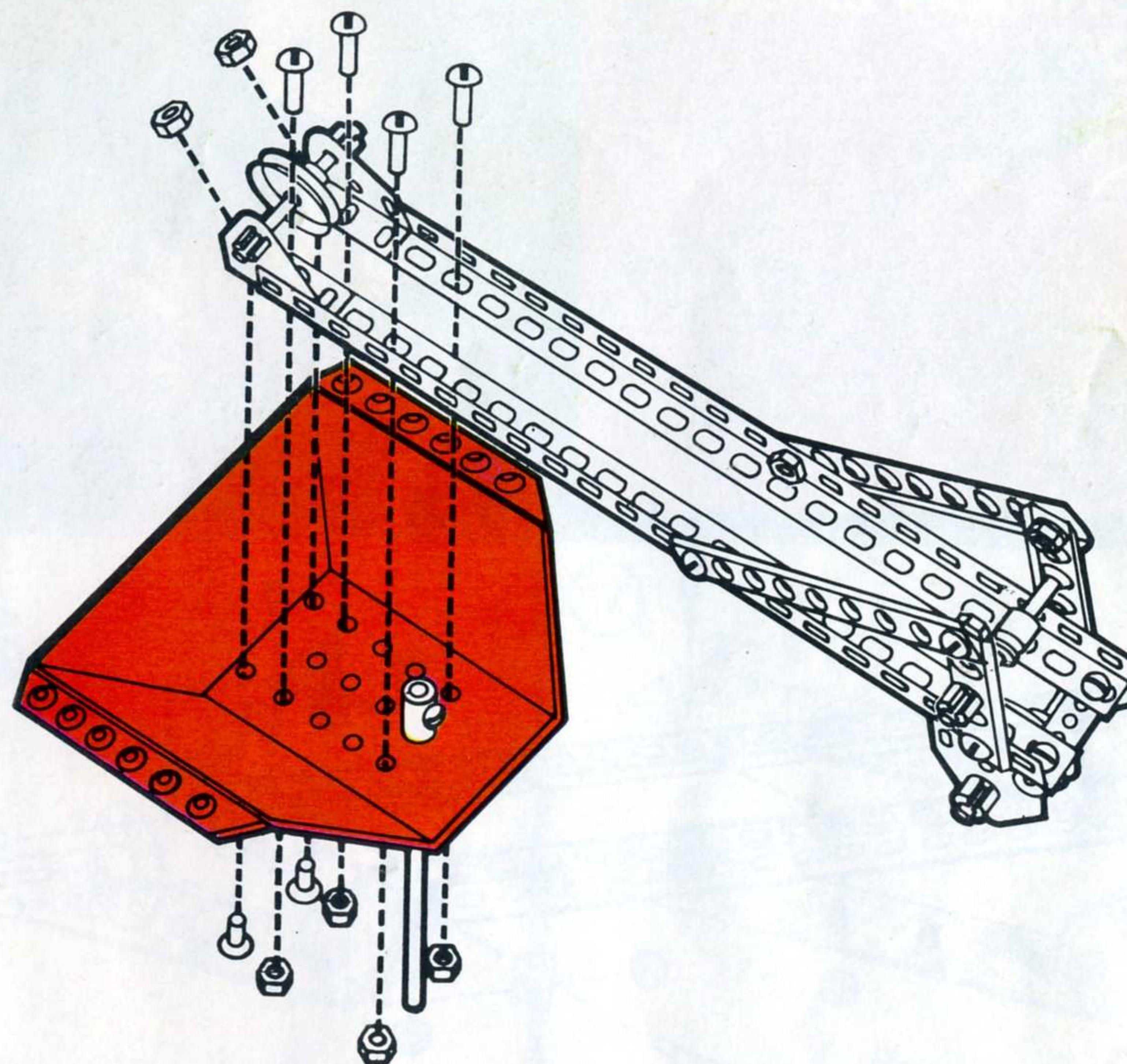

11

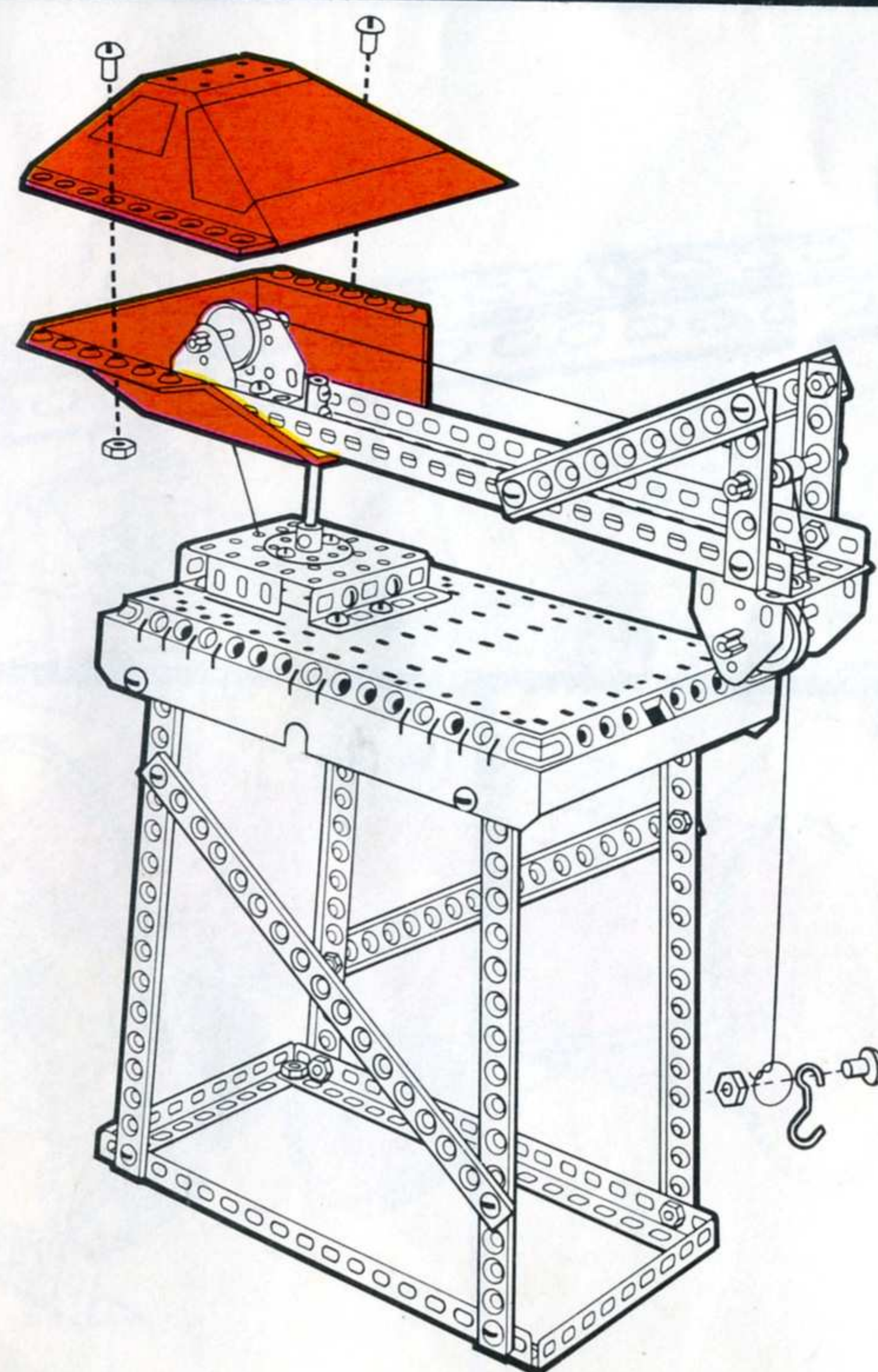



# ALL-TERRAIN LASER CANNON

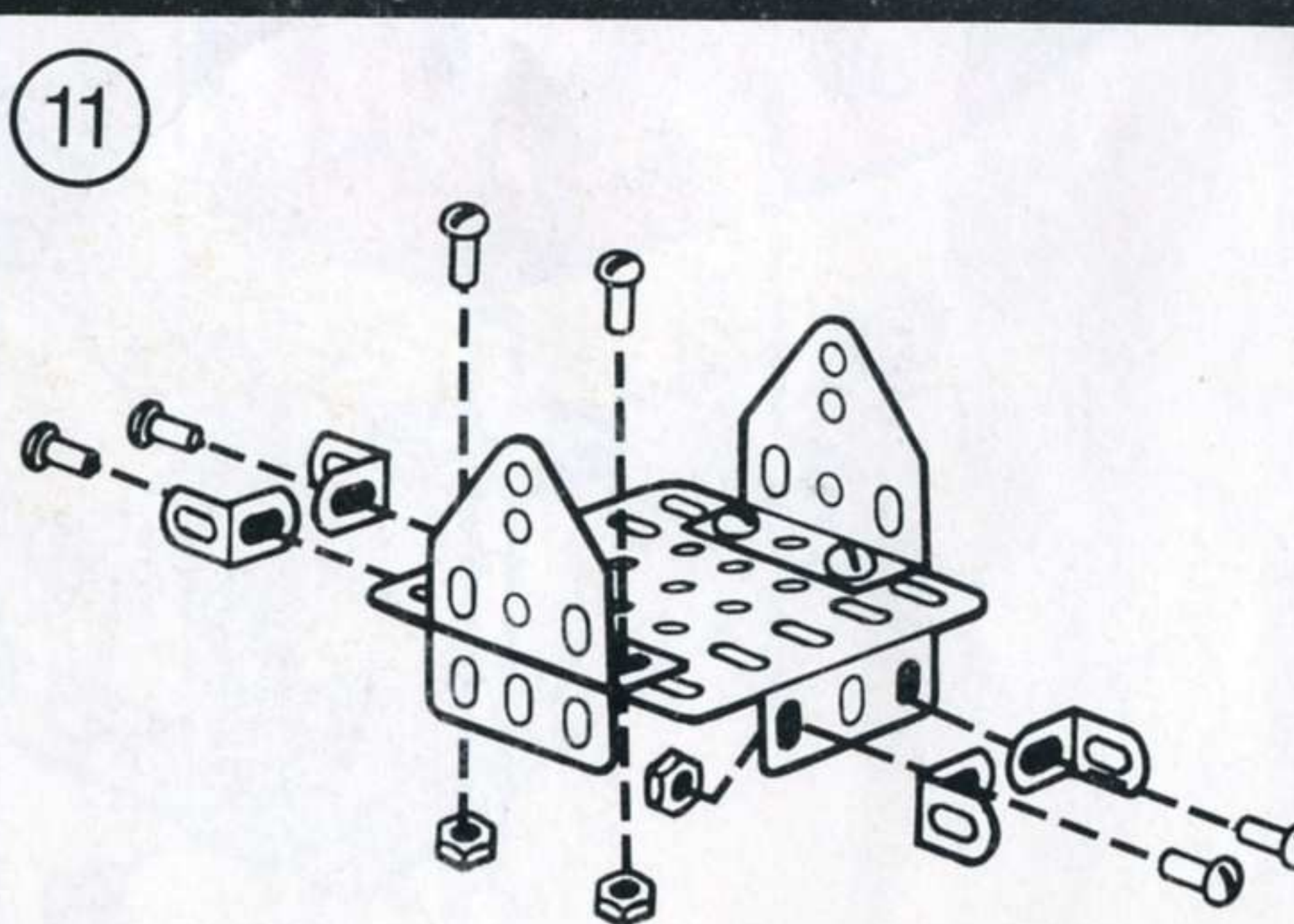
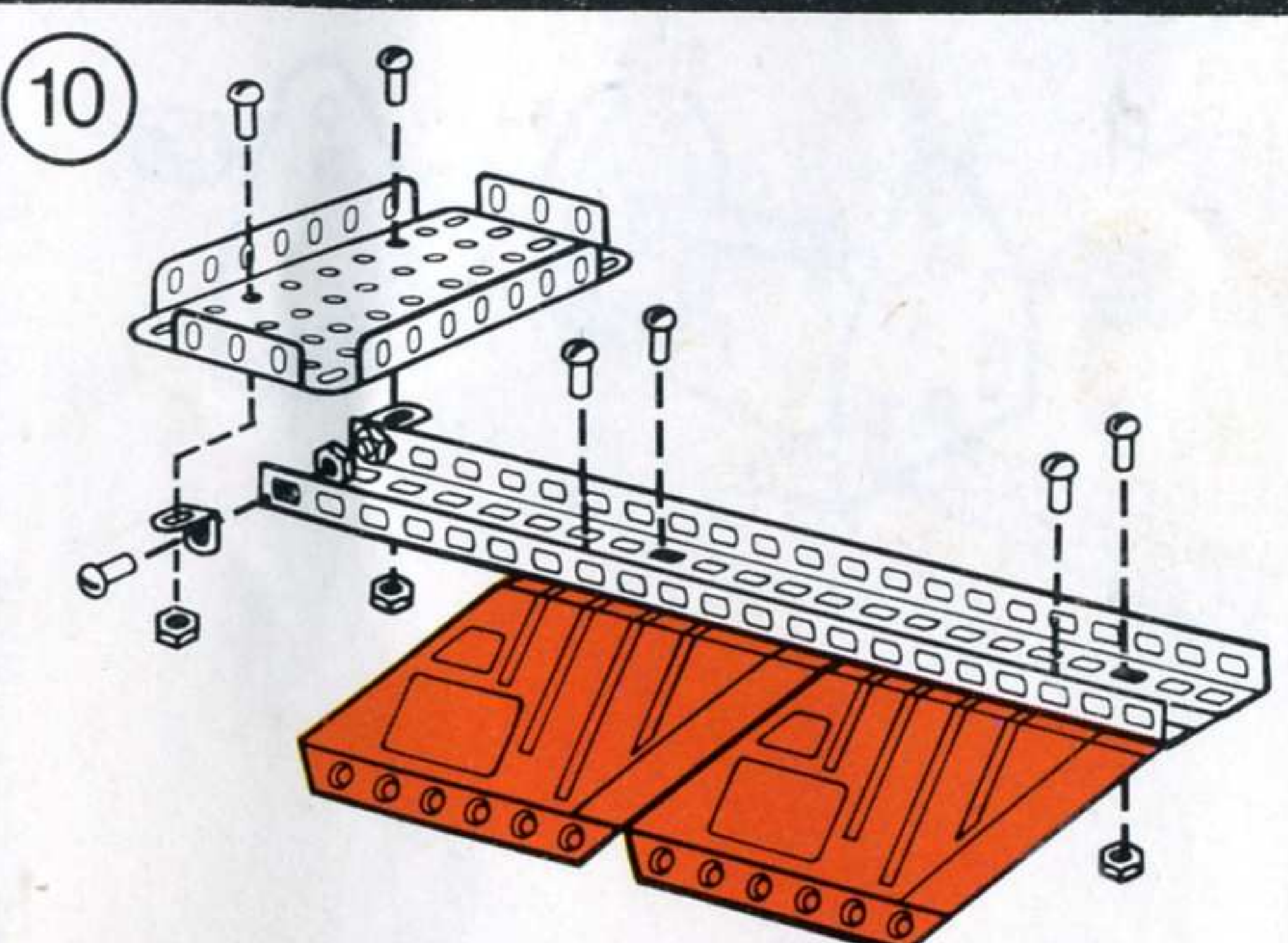
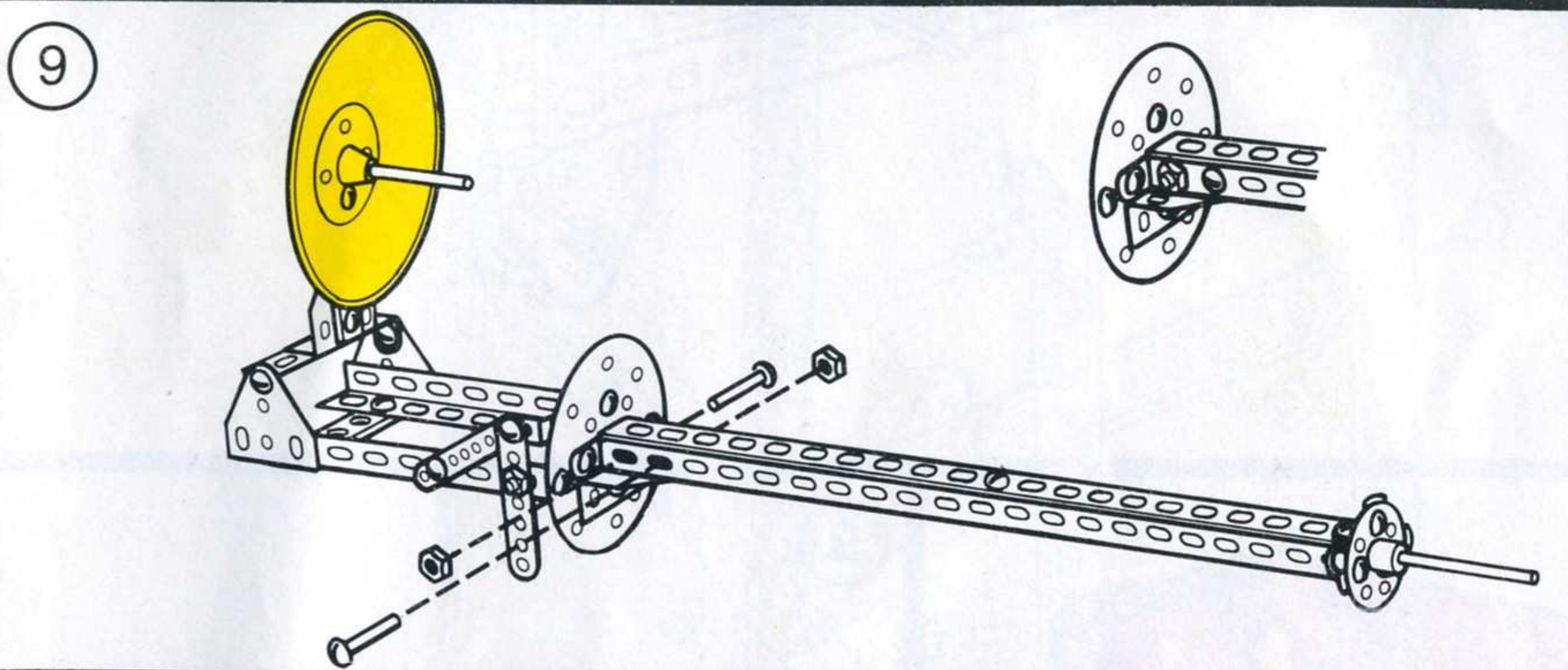
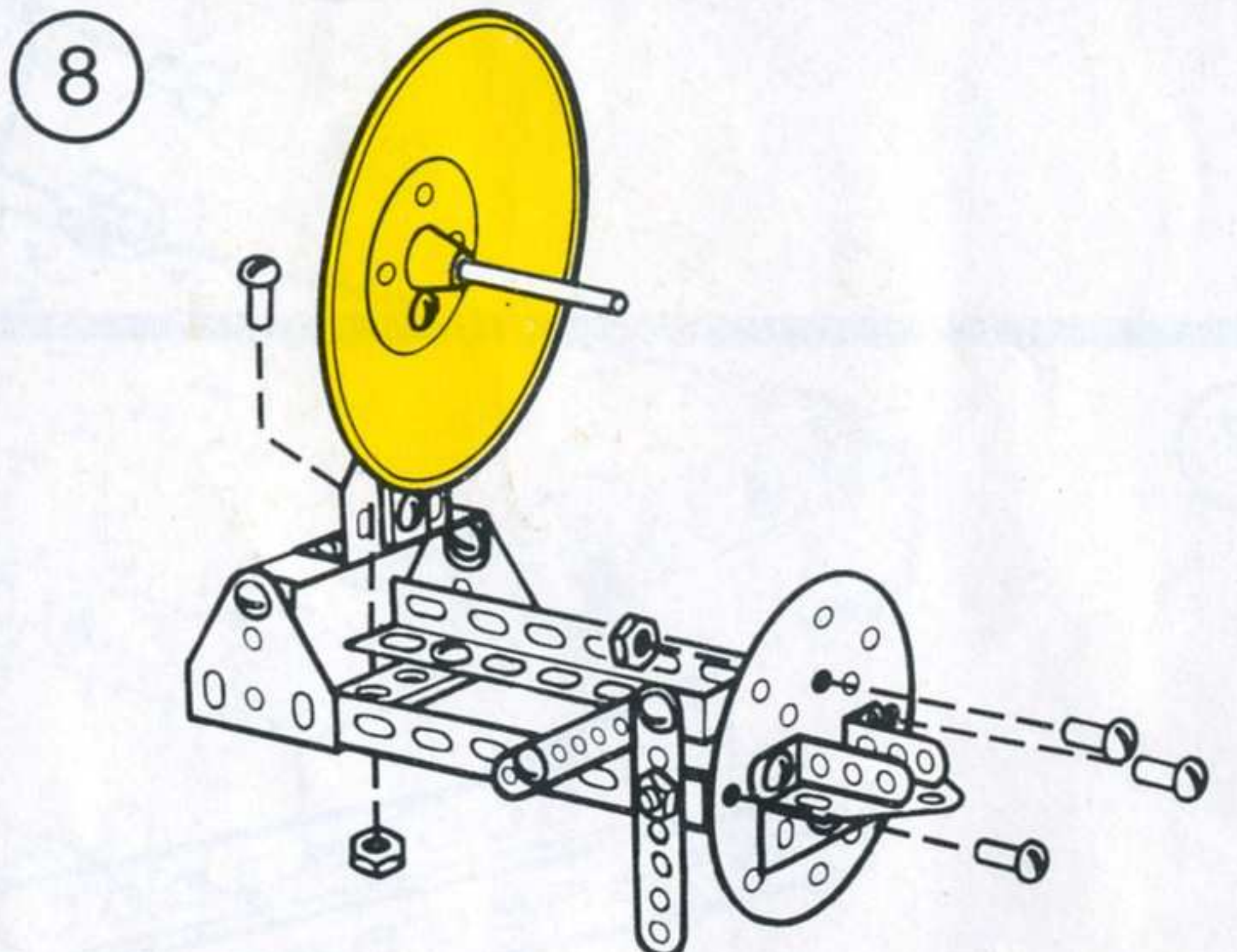
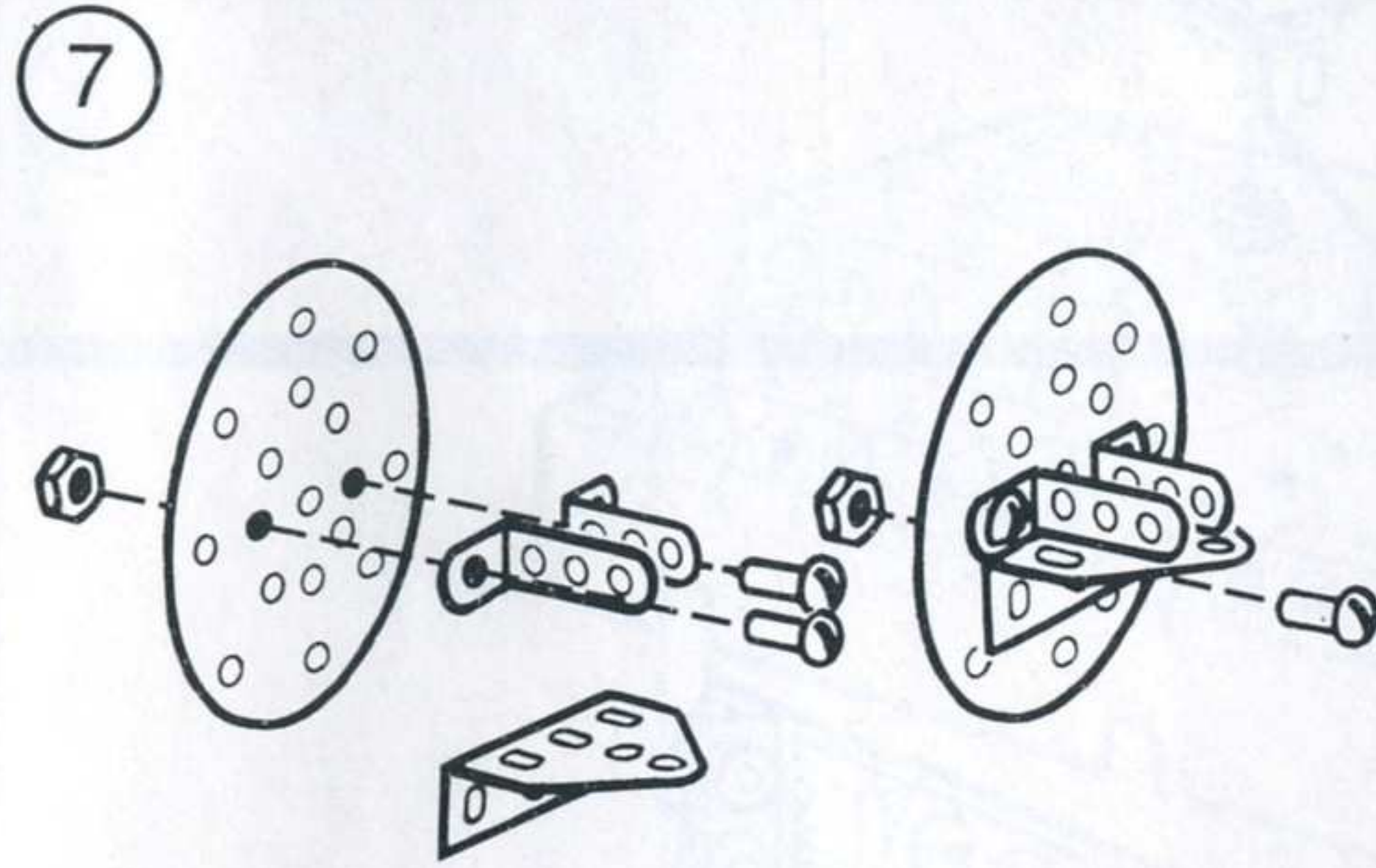
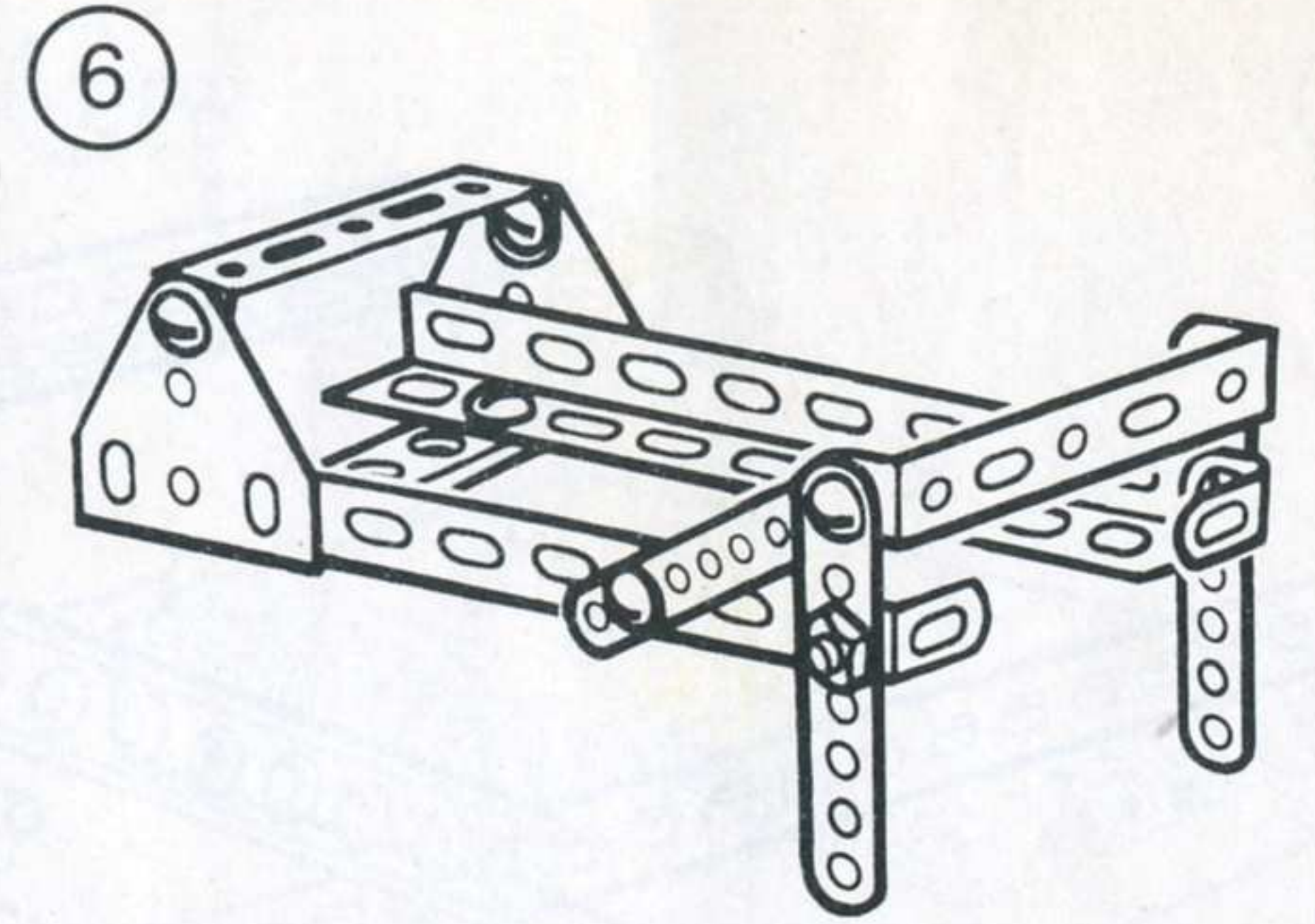
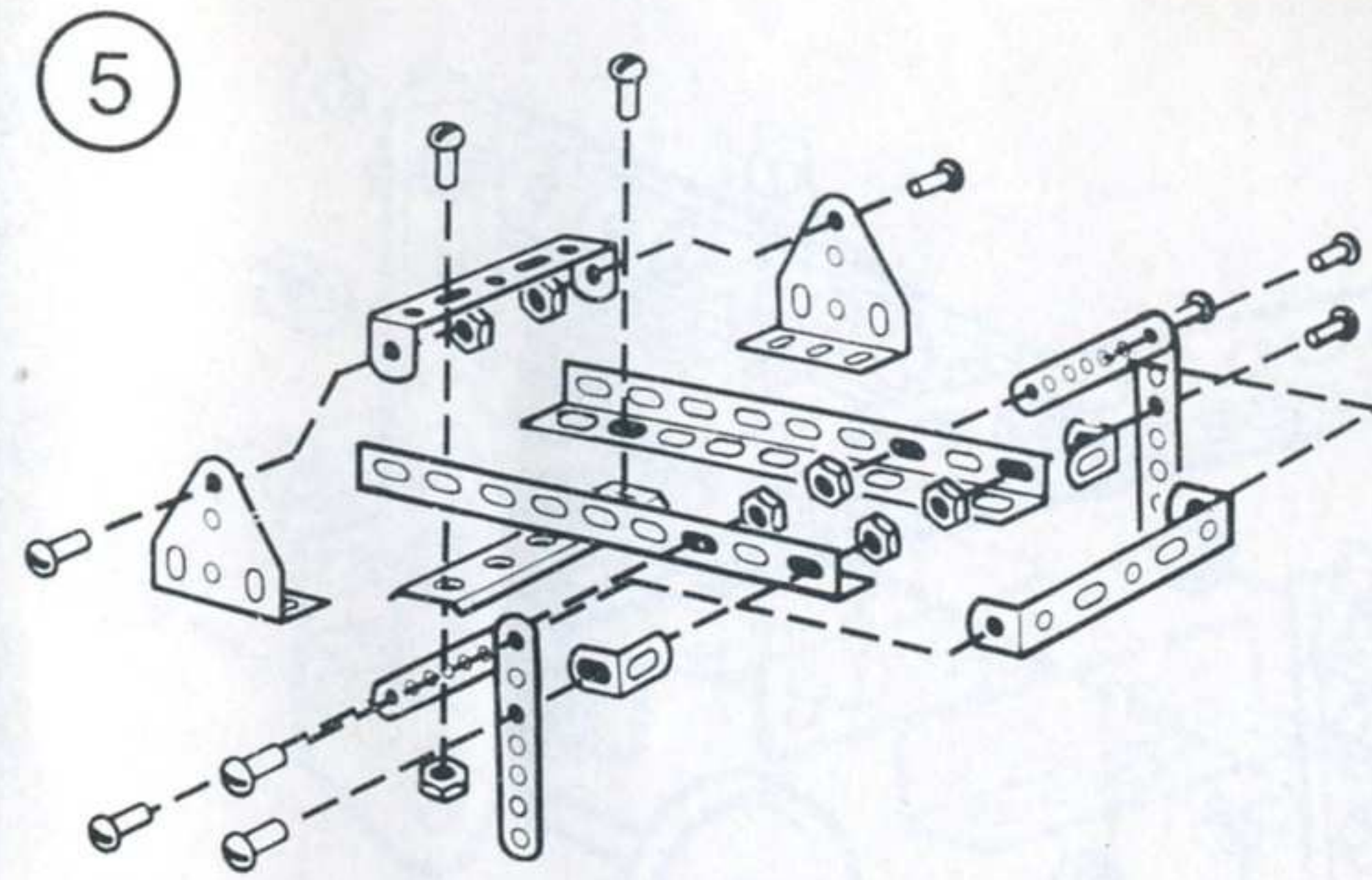
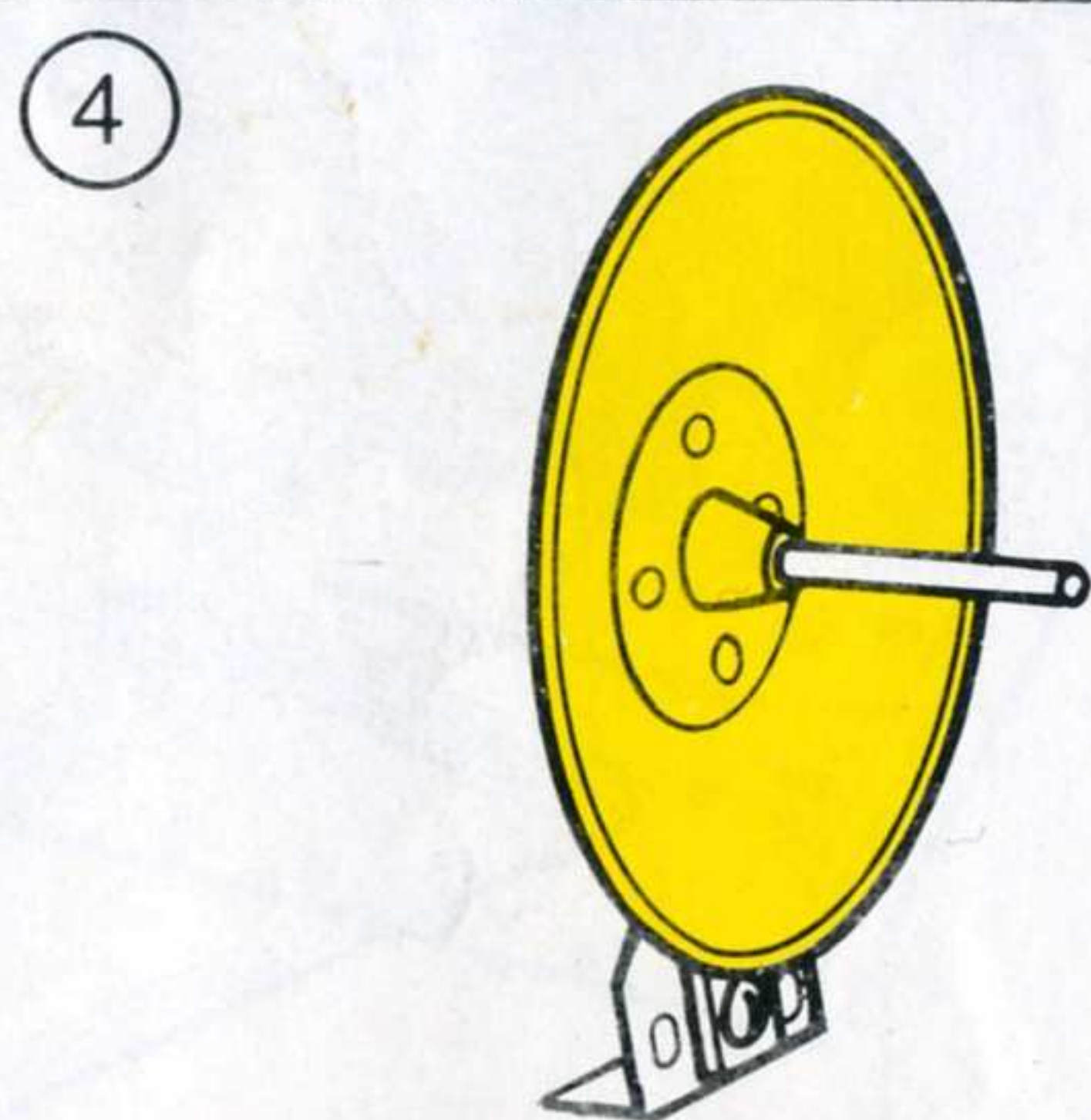
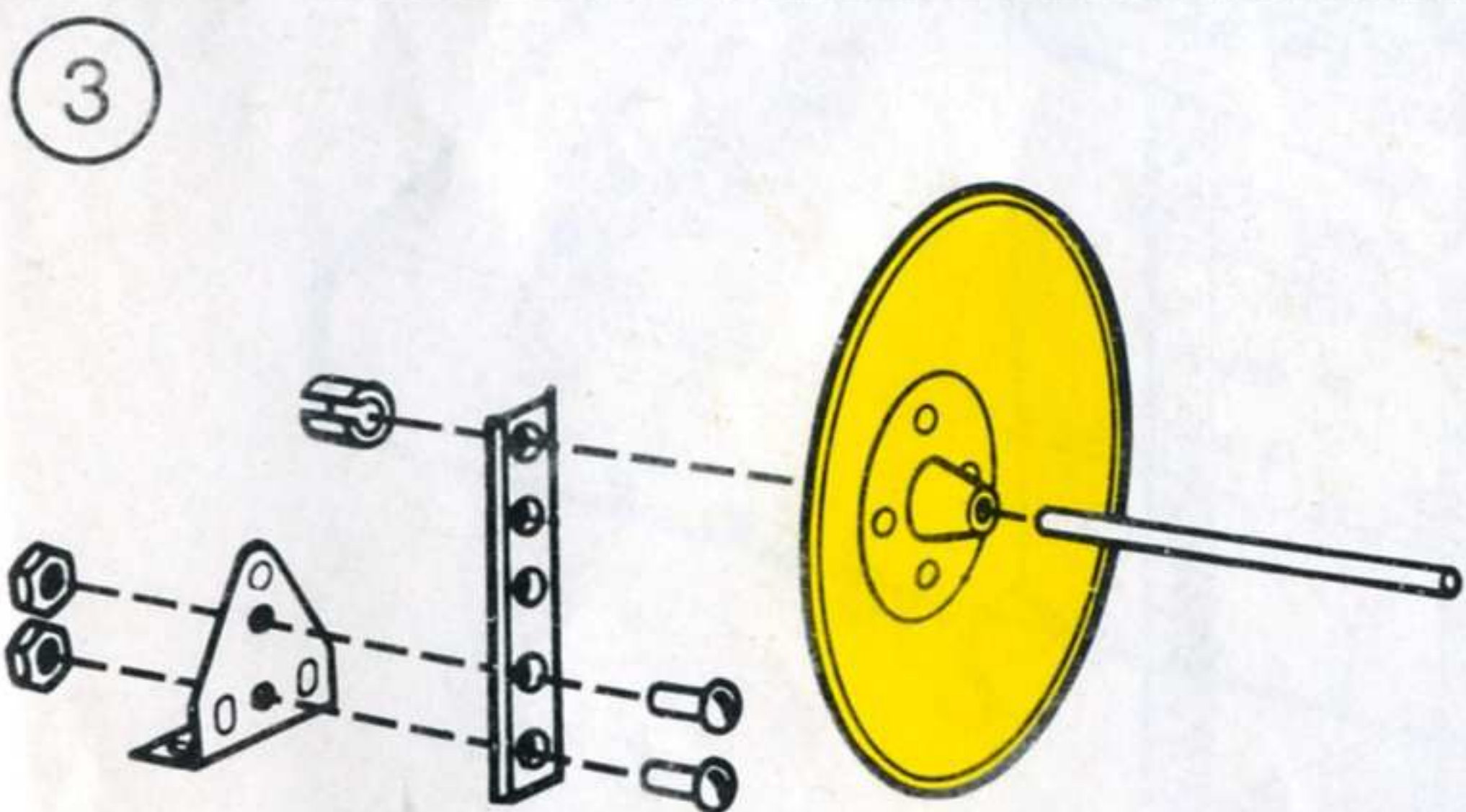
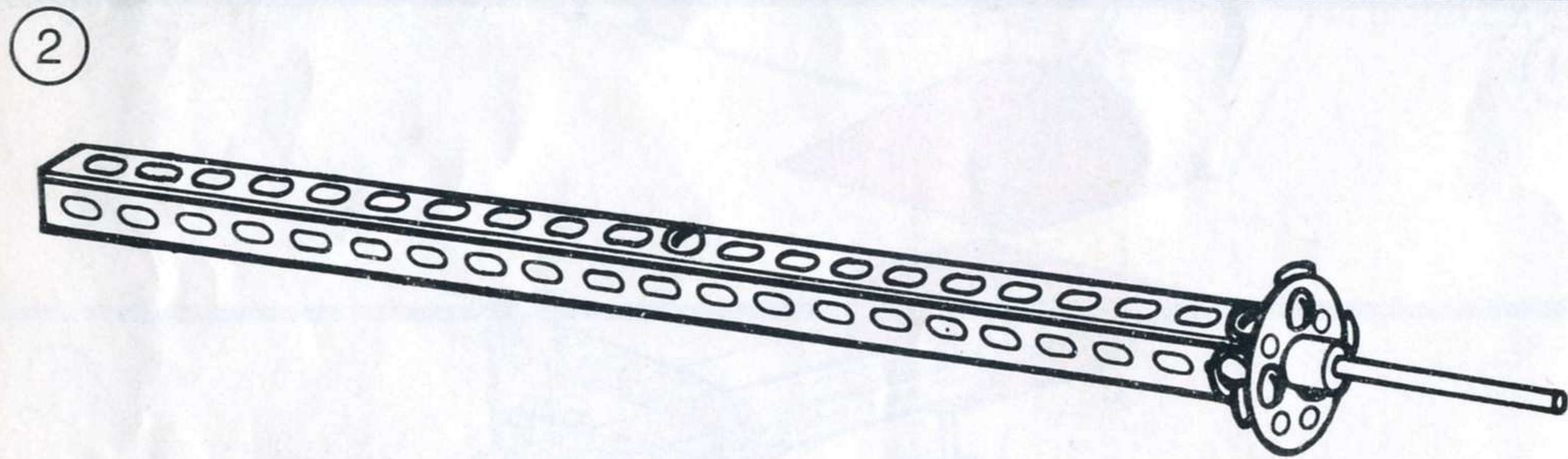
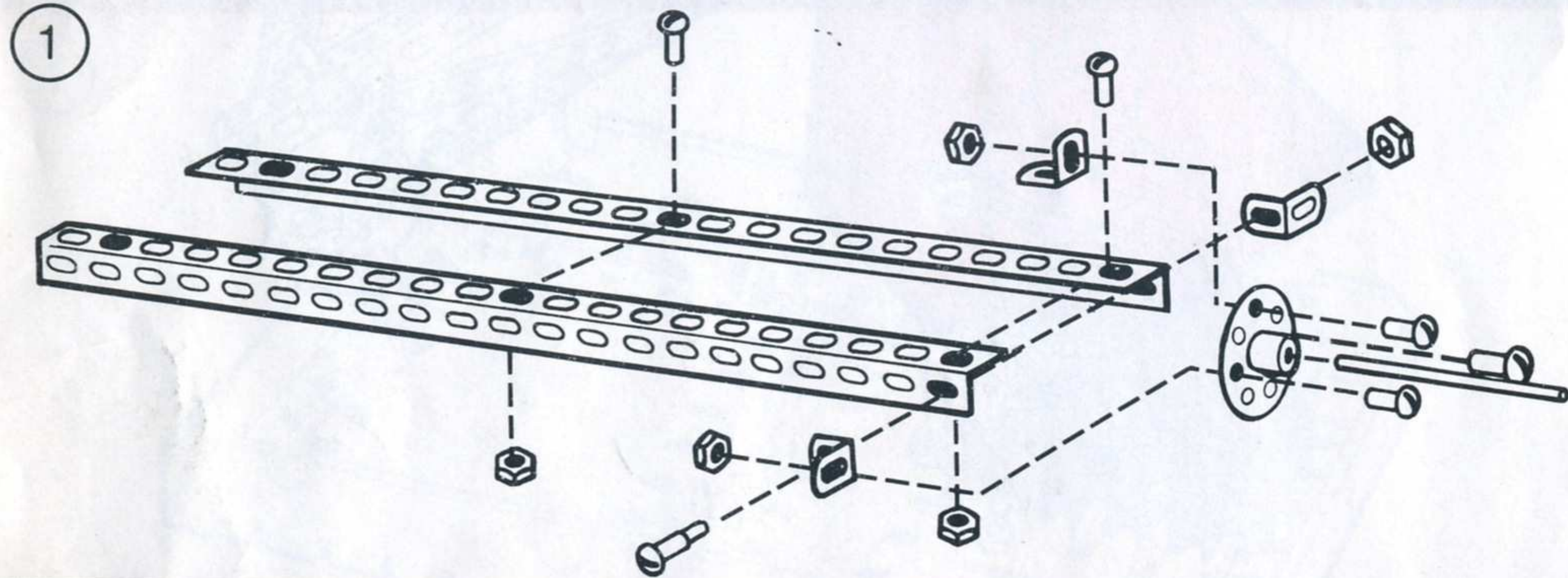
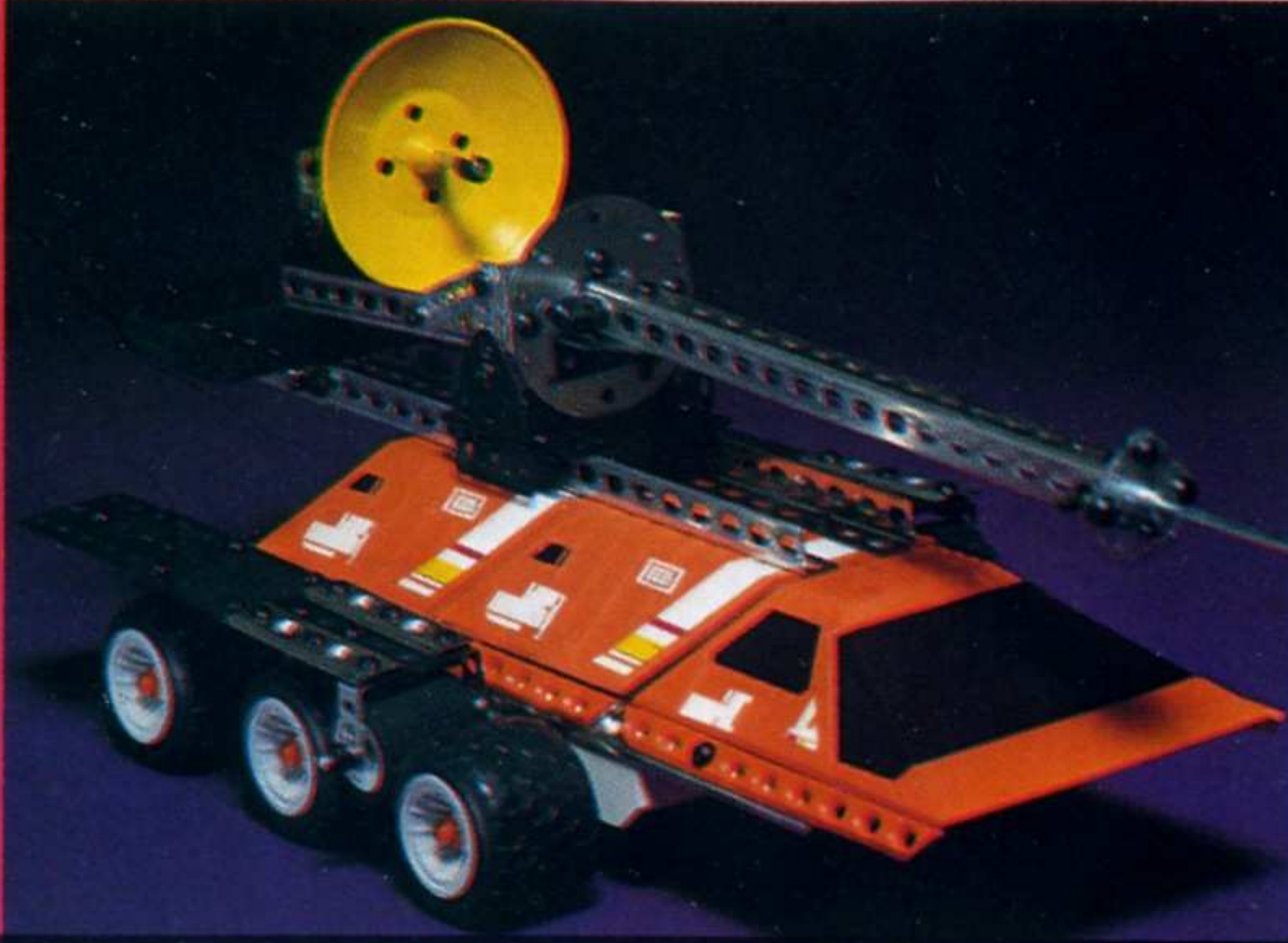



12

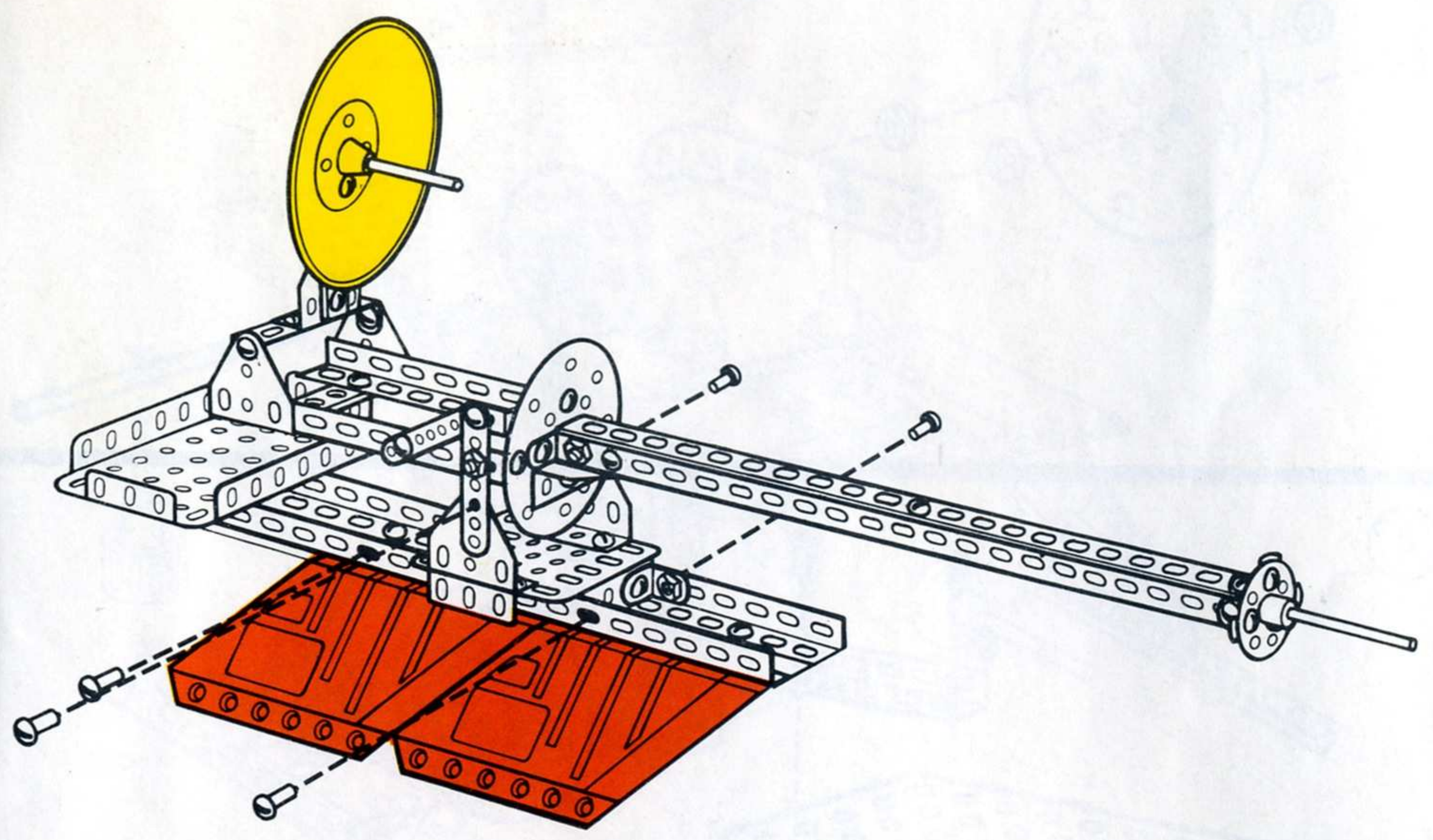

14

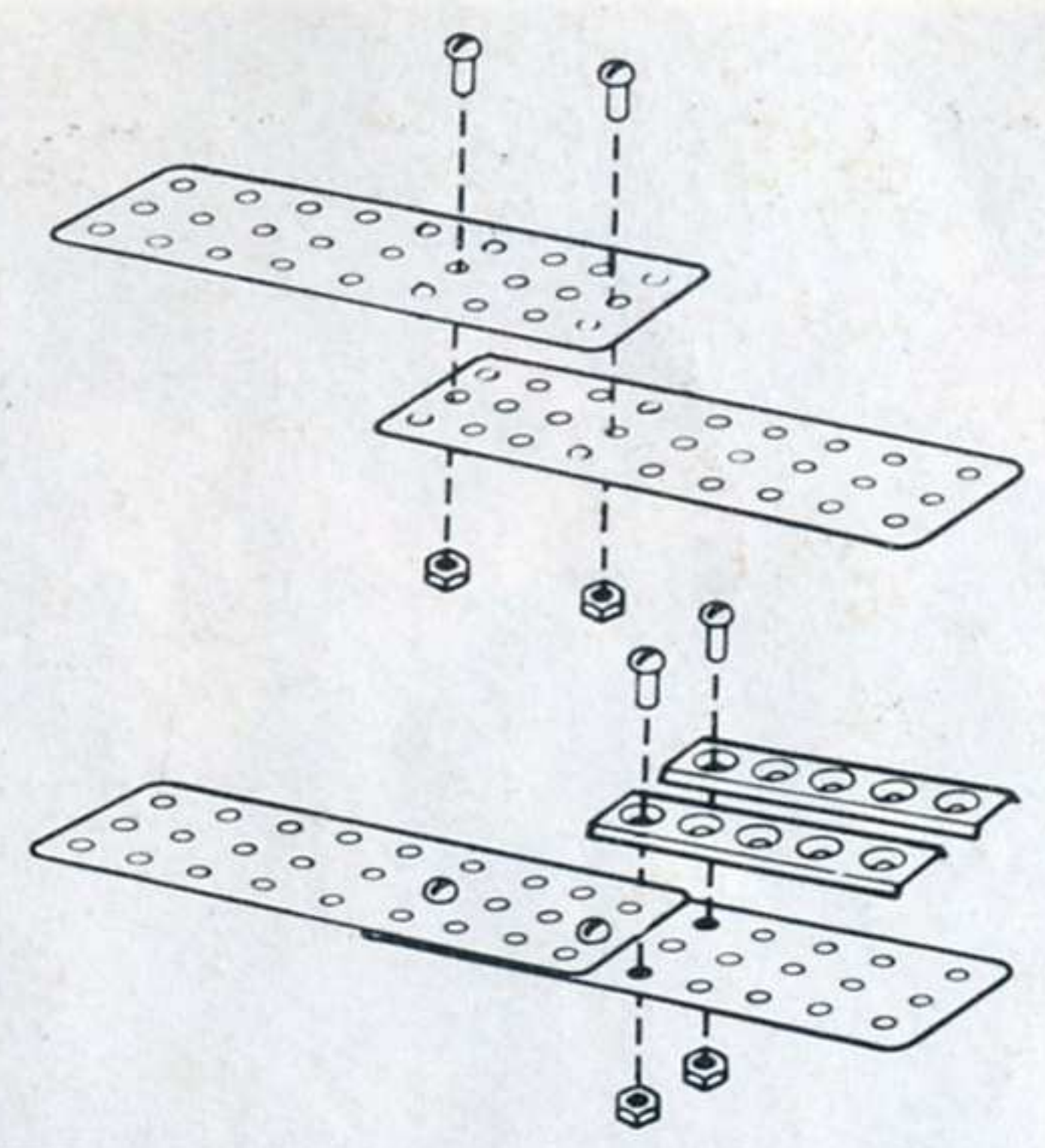

15

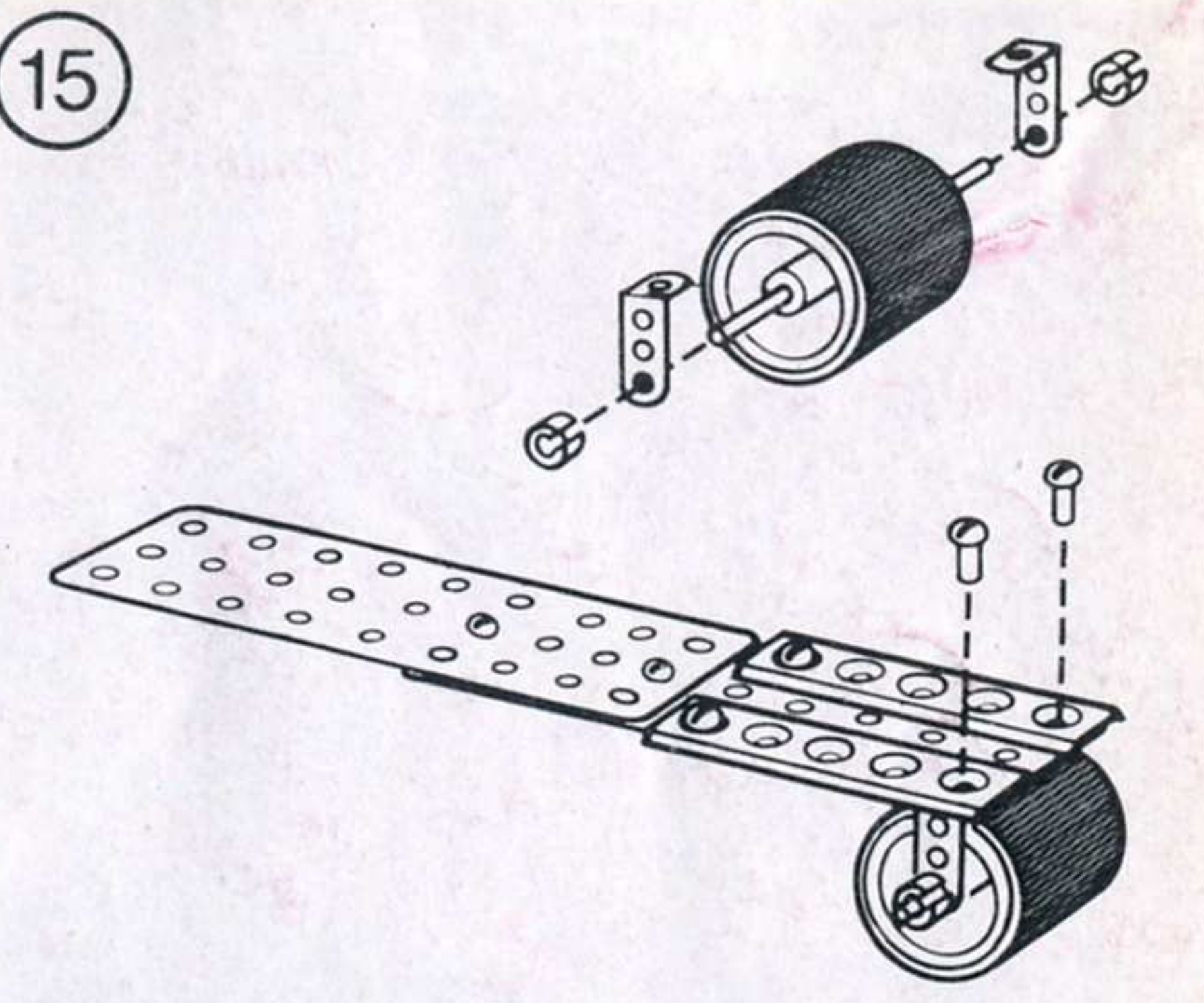

16

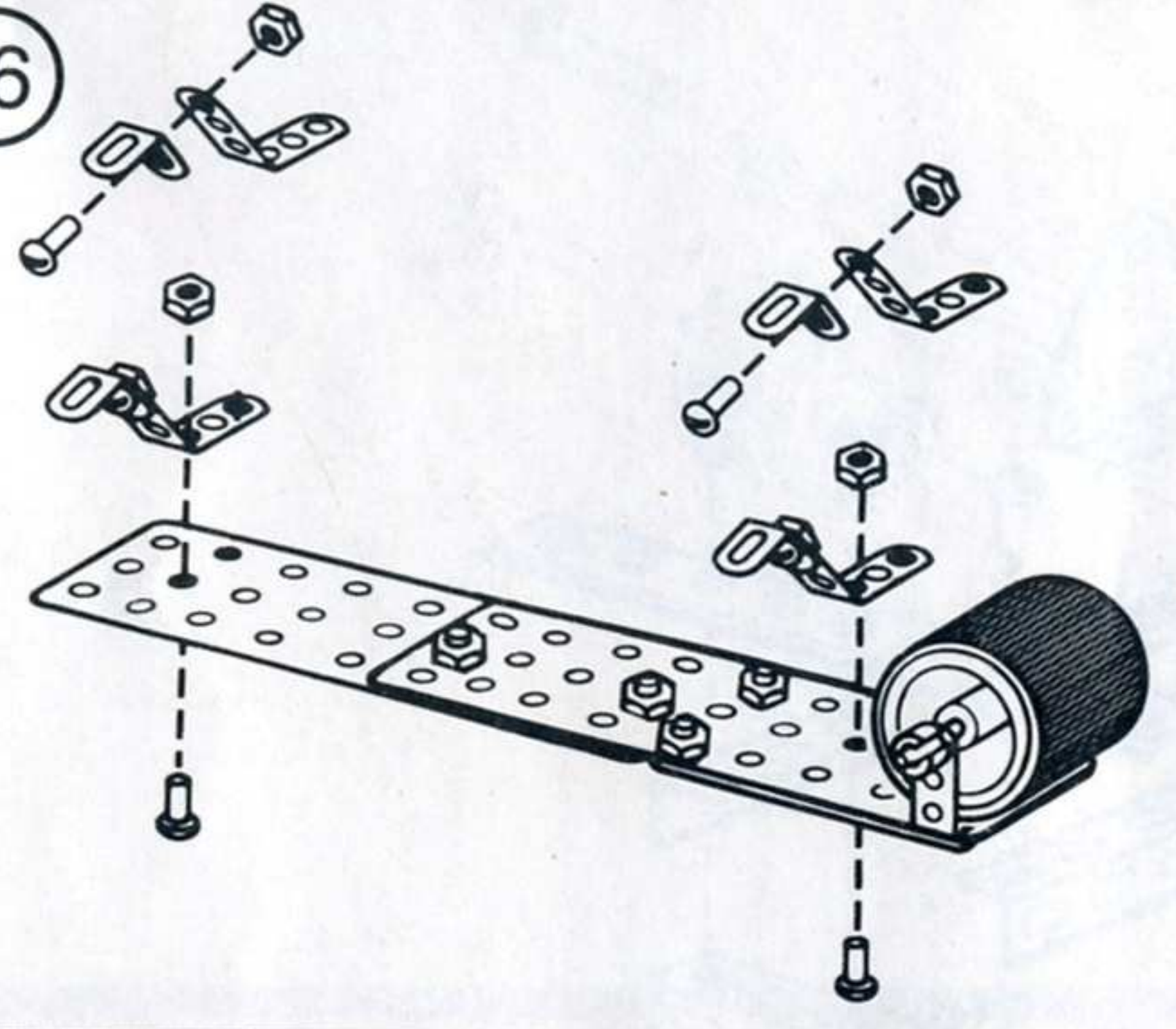

17

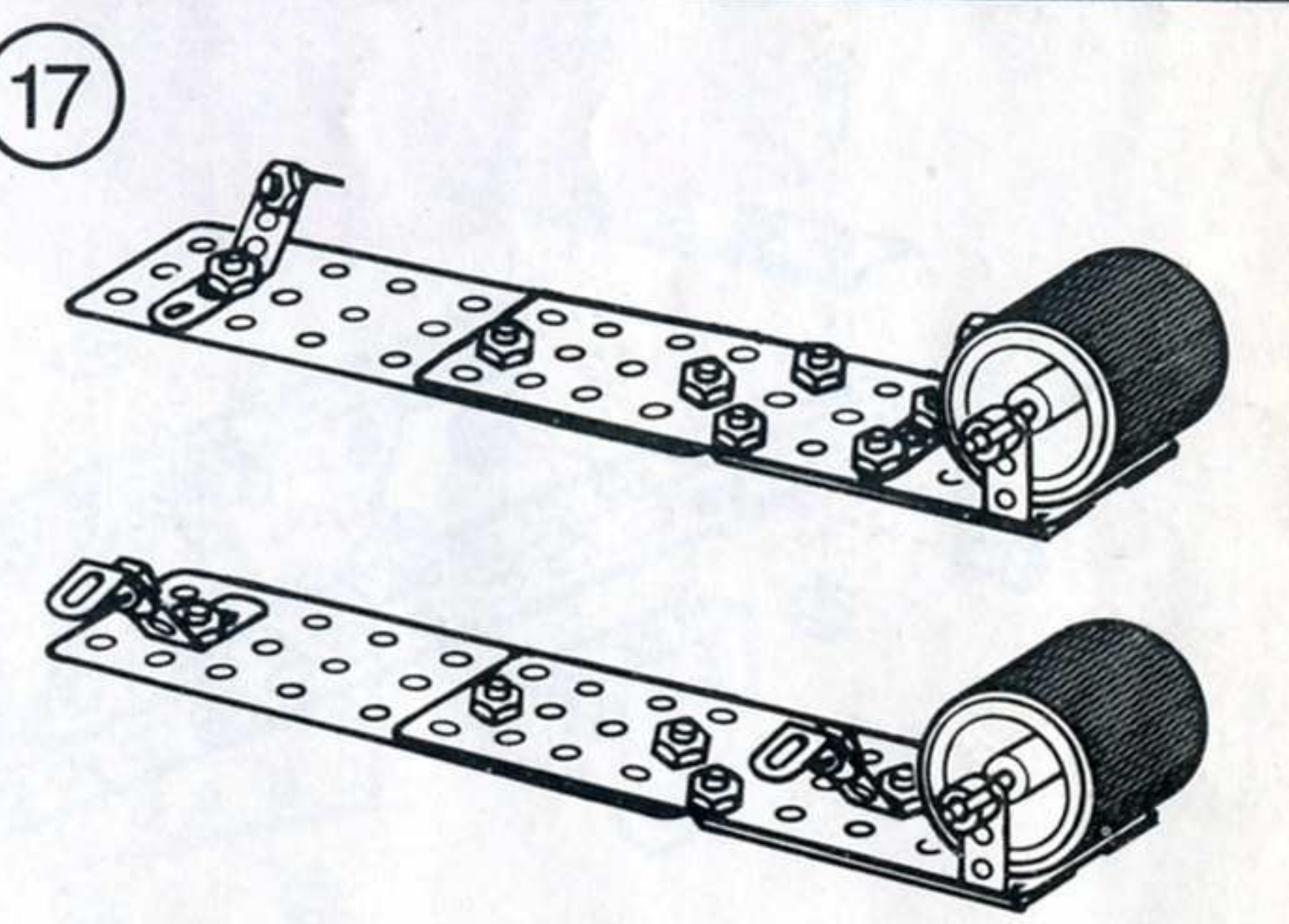

13

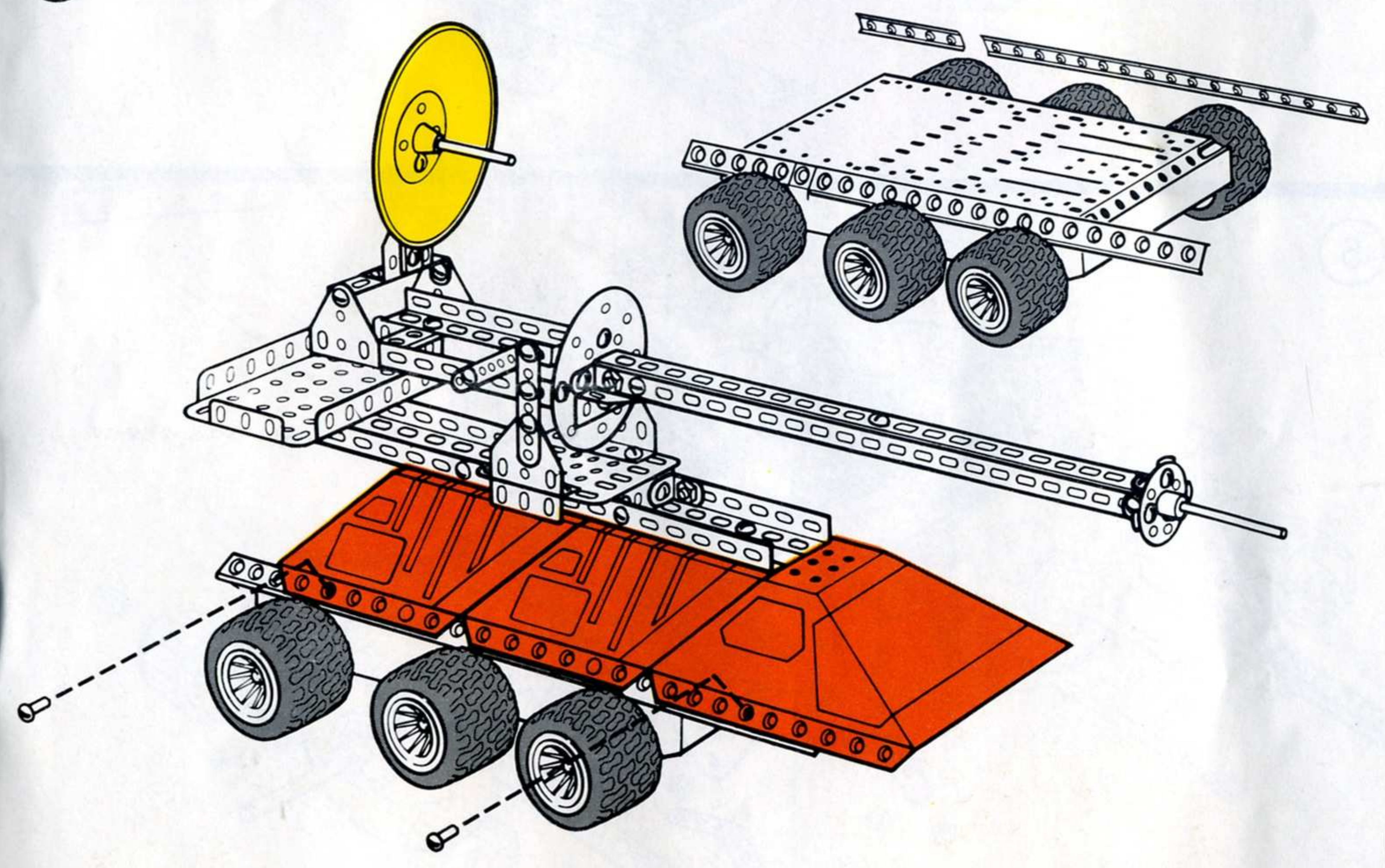

18

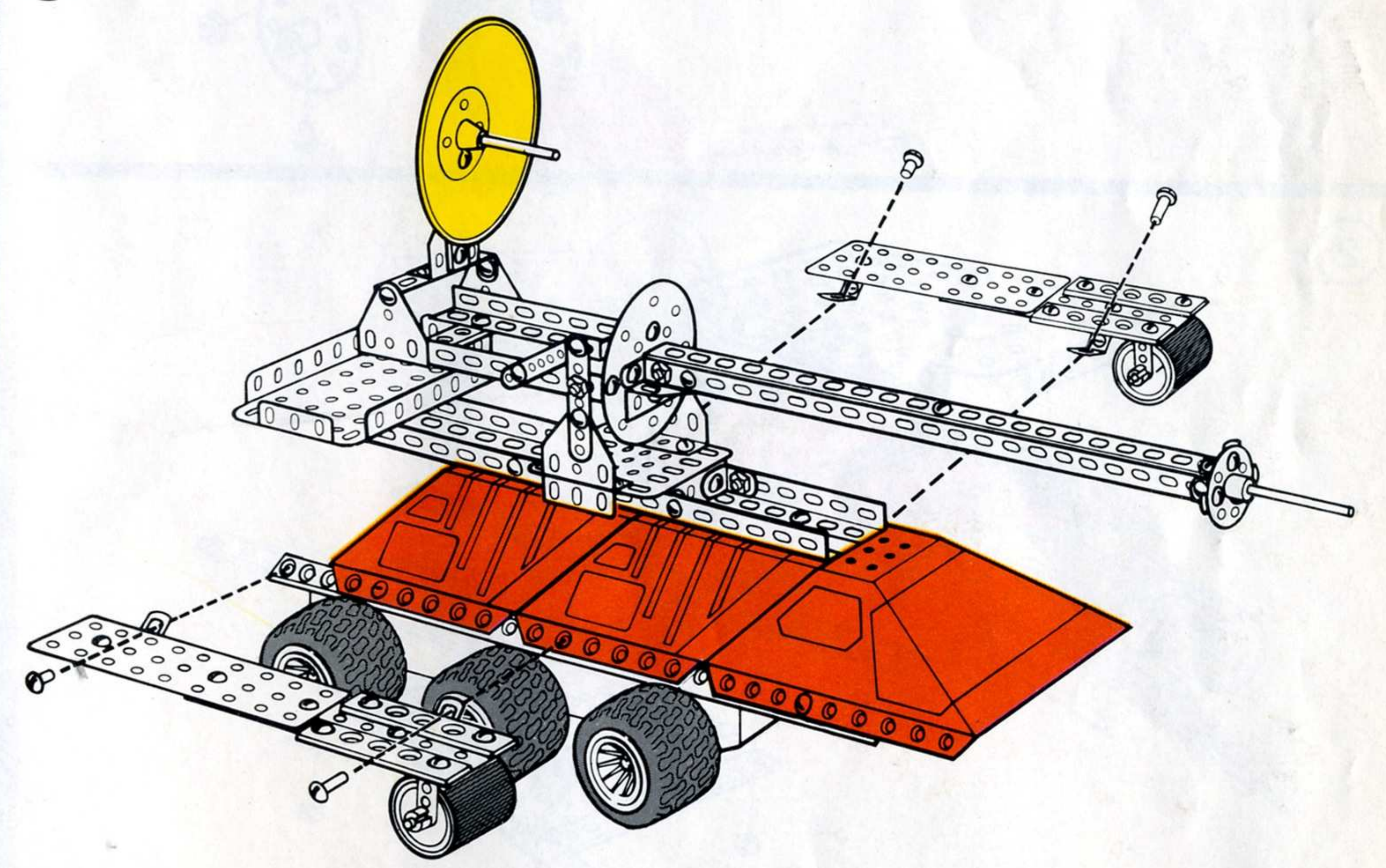



# INTERPLANETARY SHUTTLE

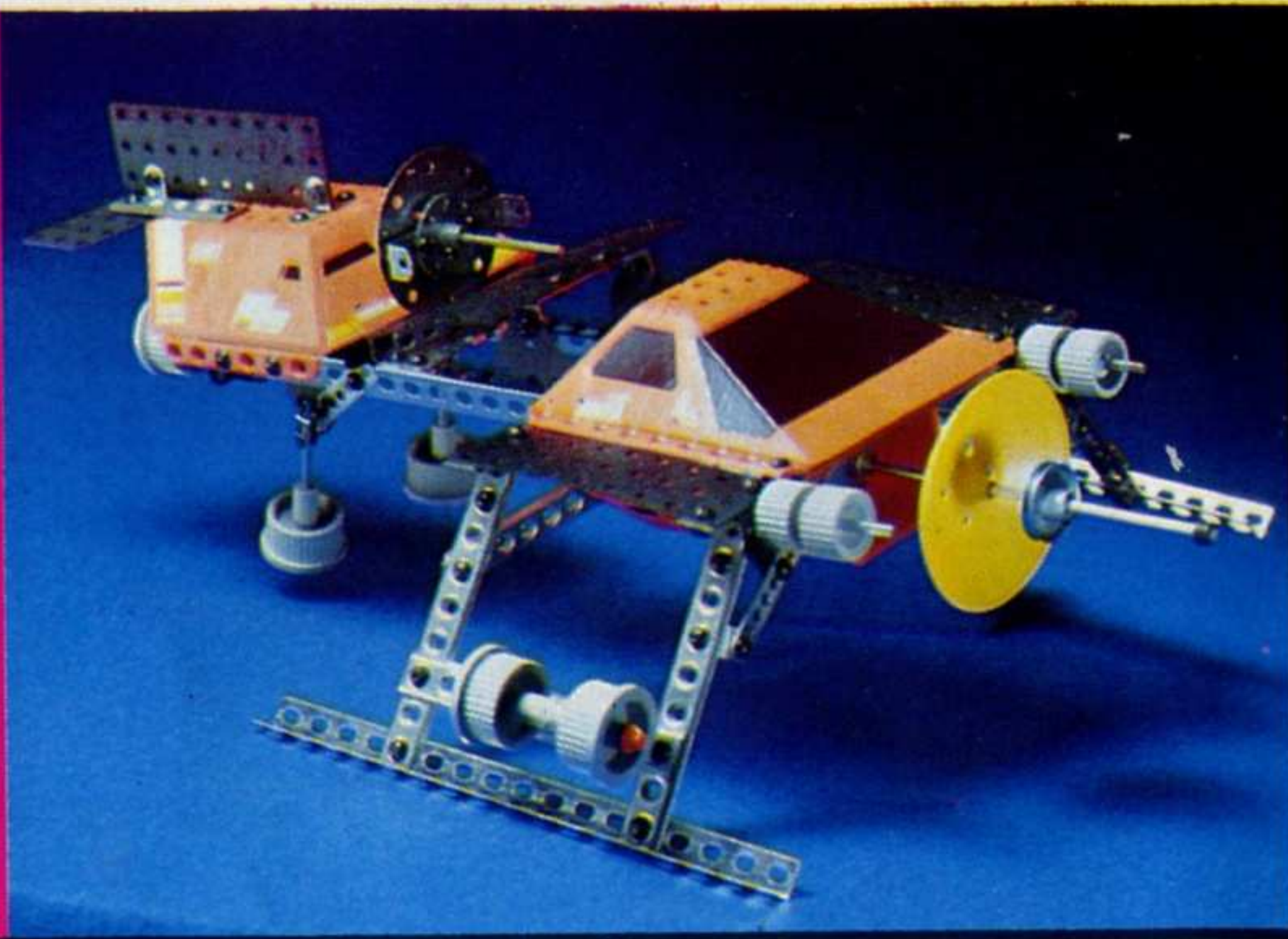

1

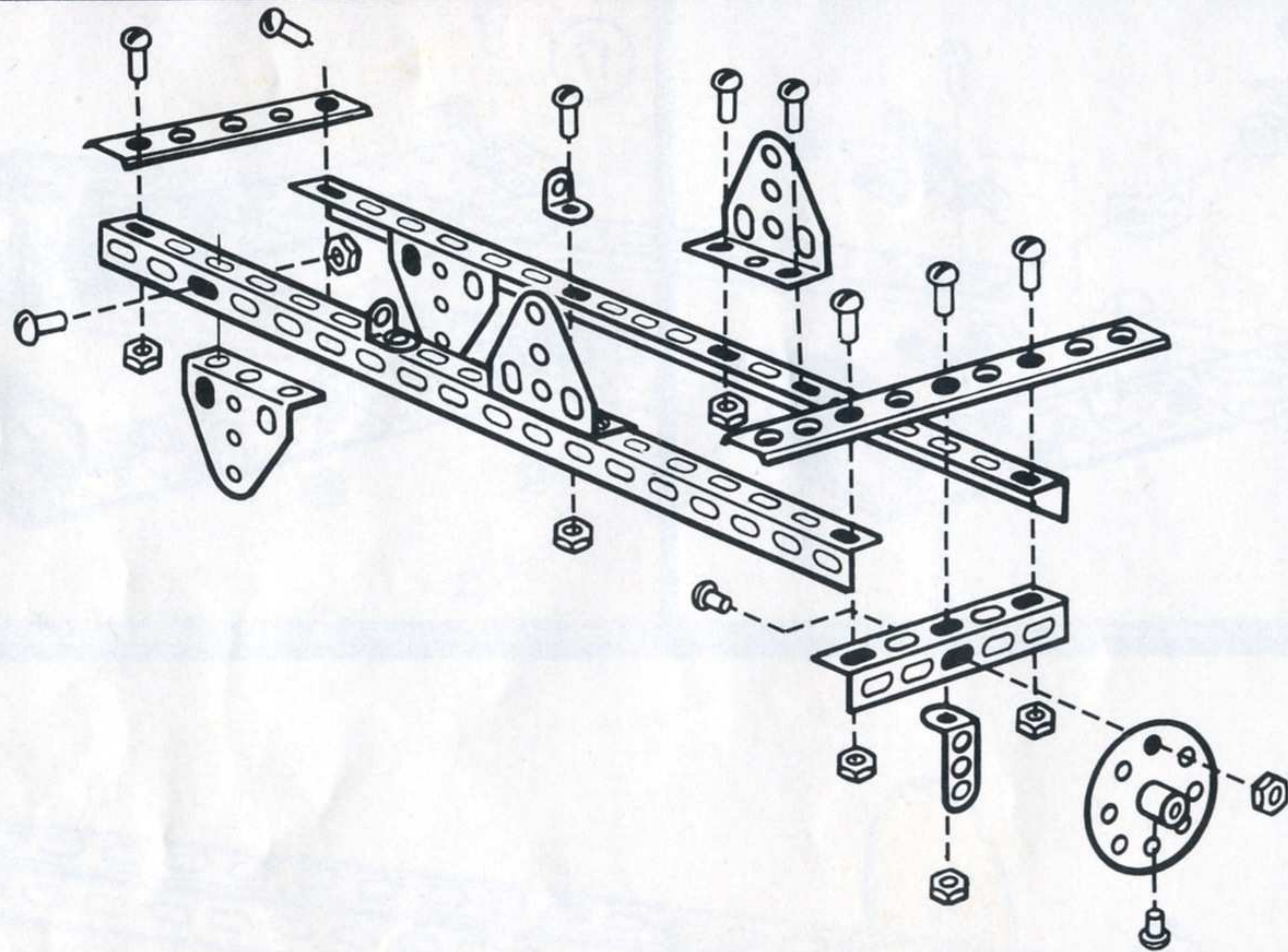

3

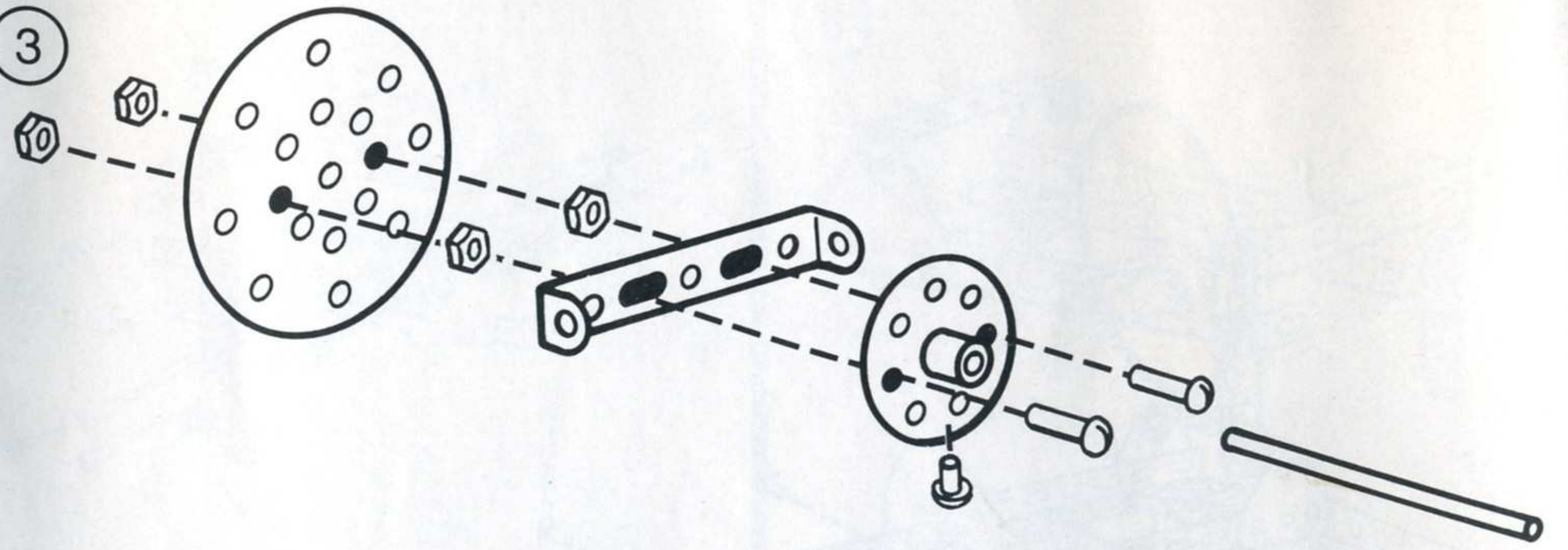

4

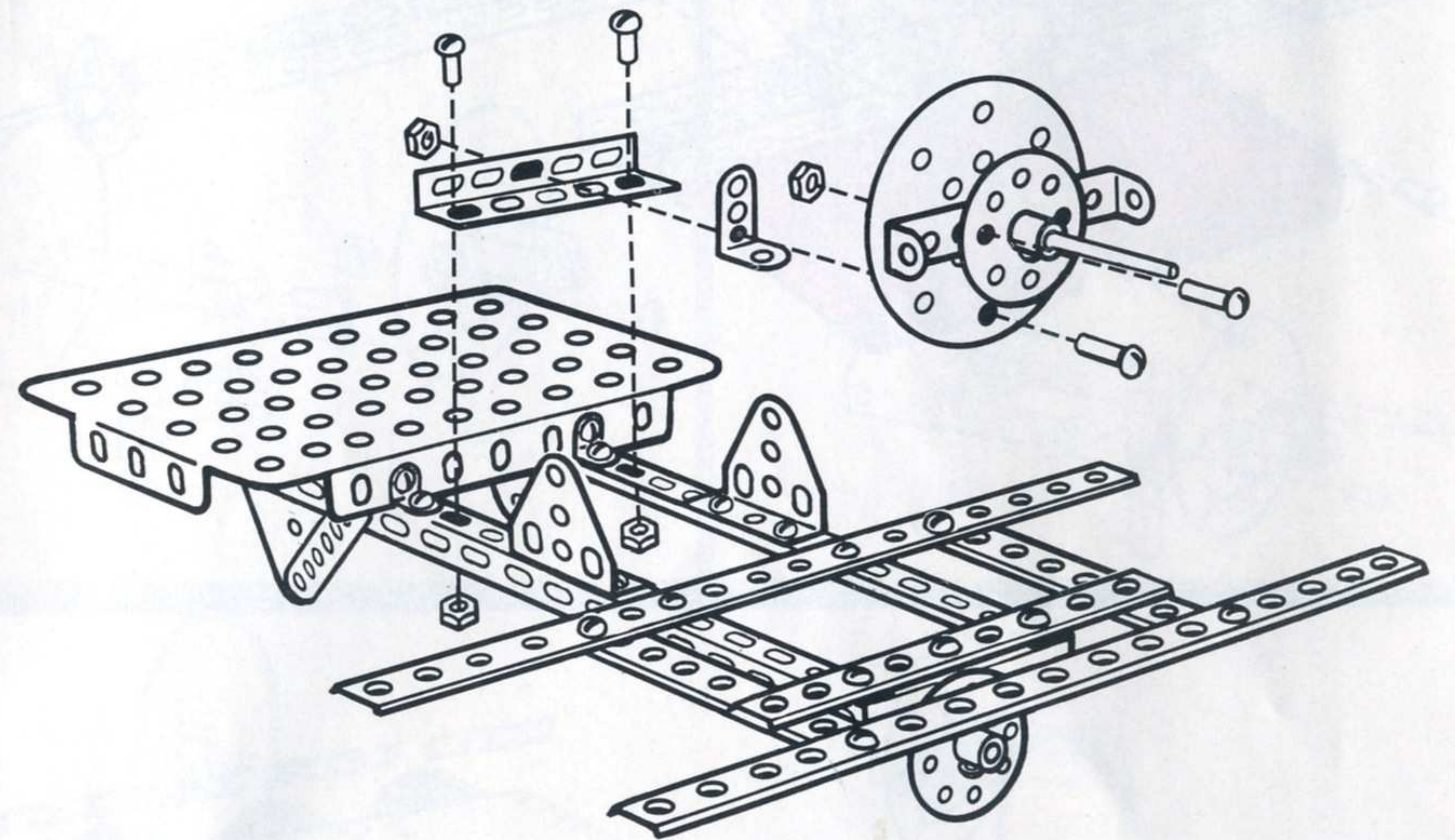

2

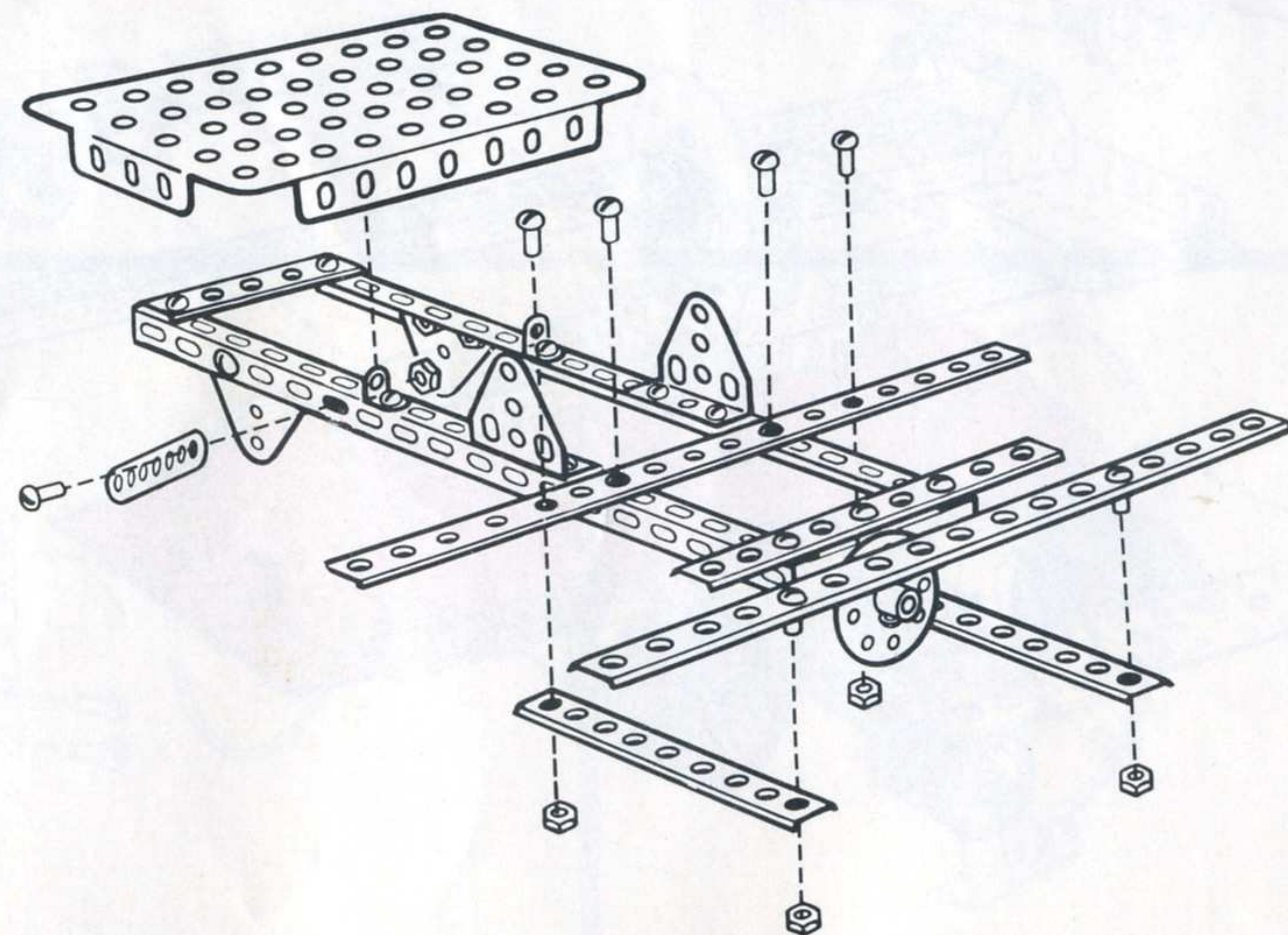

5

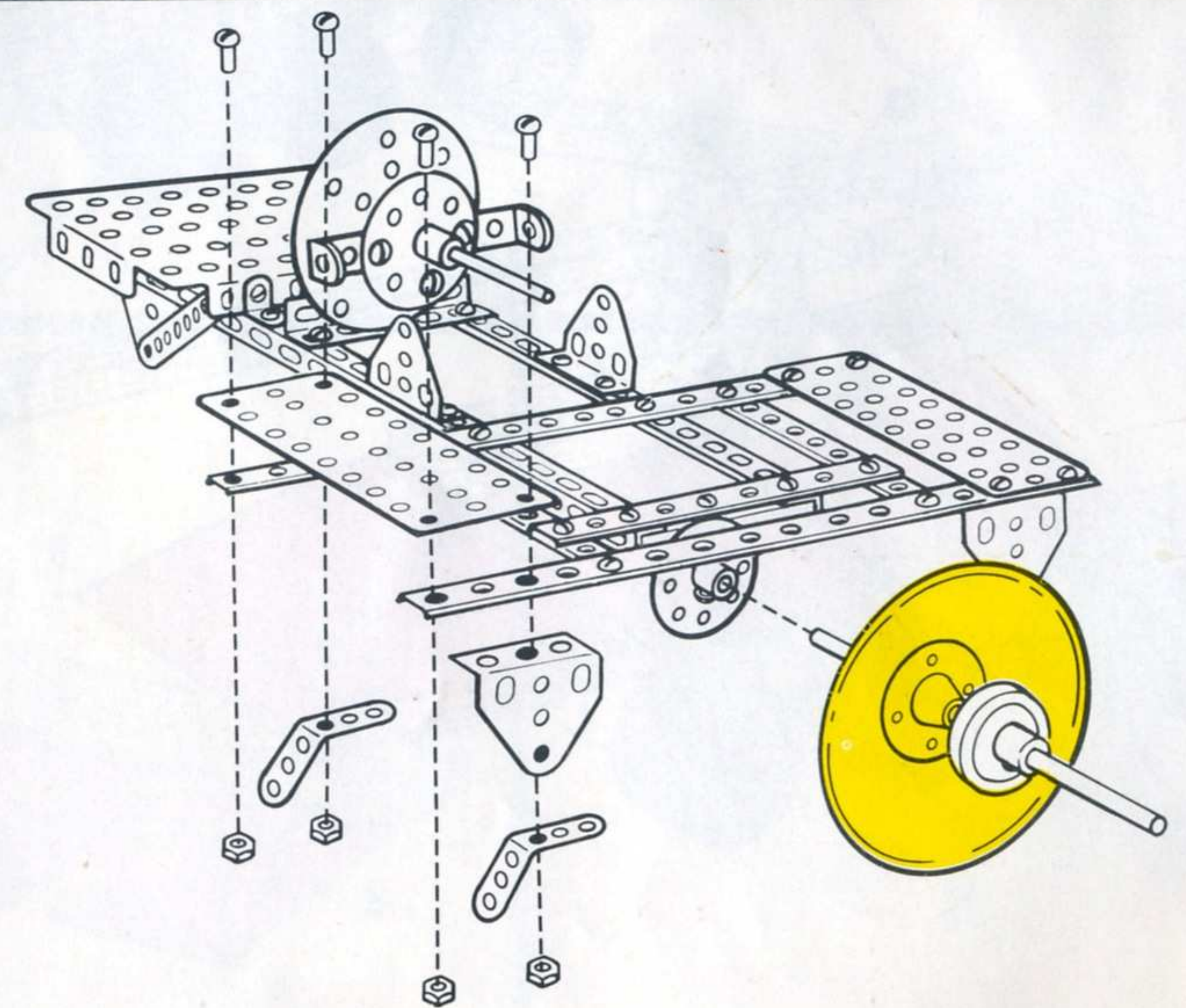



6

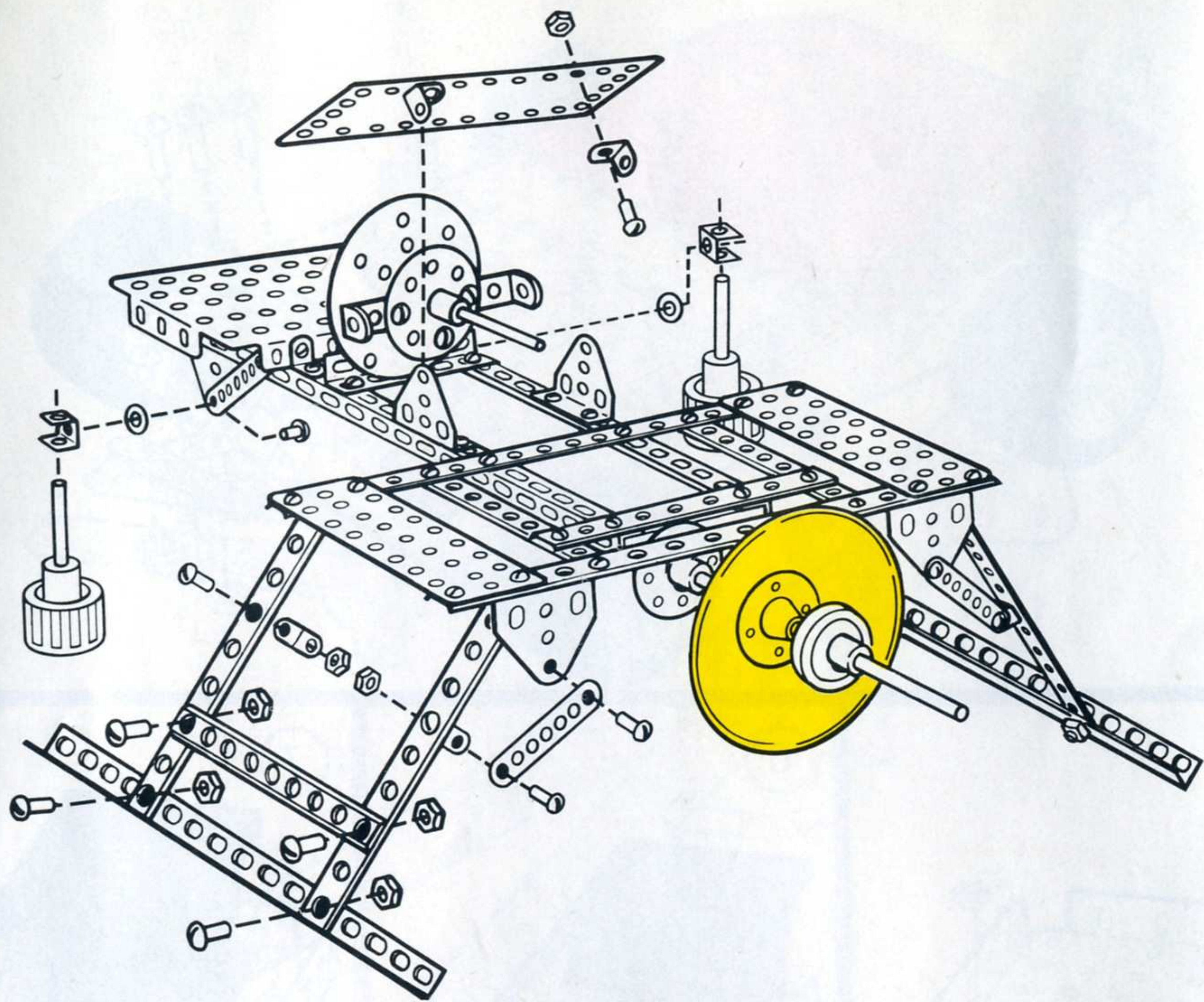

8

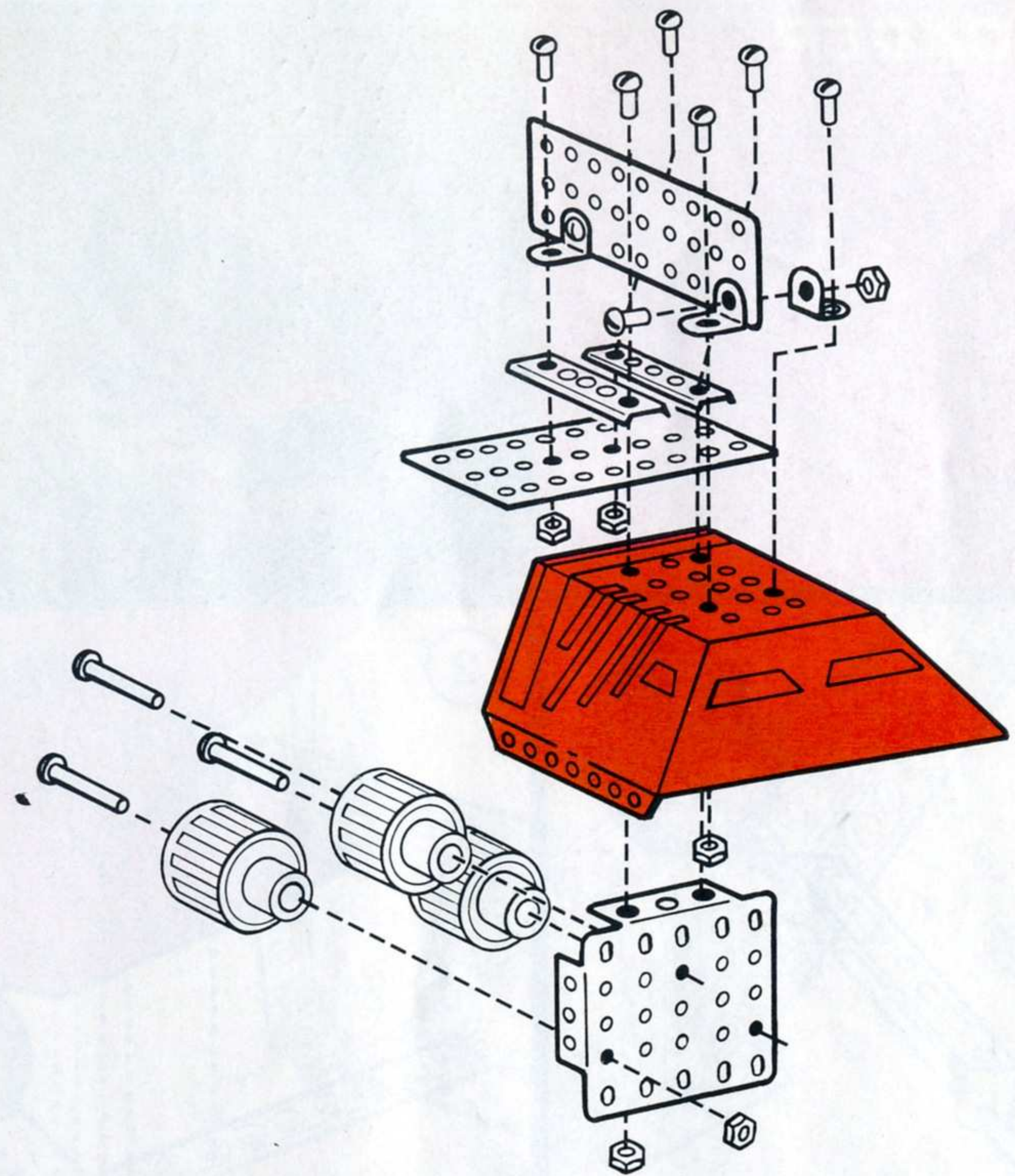

7

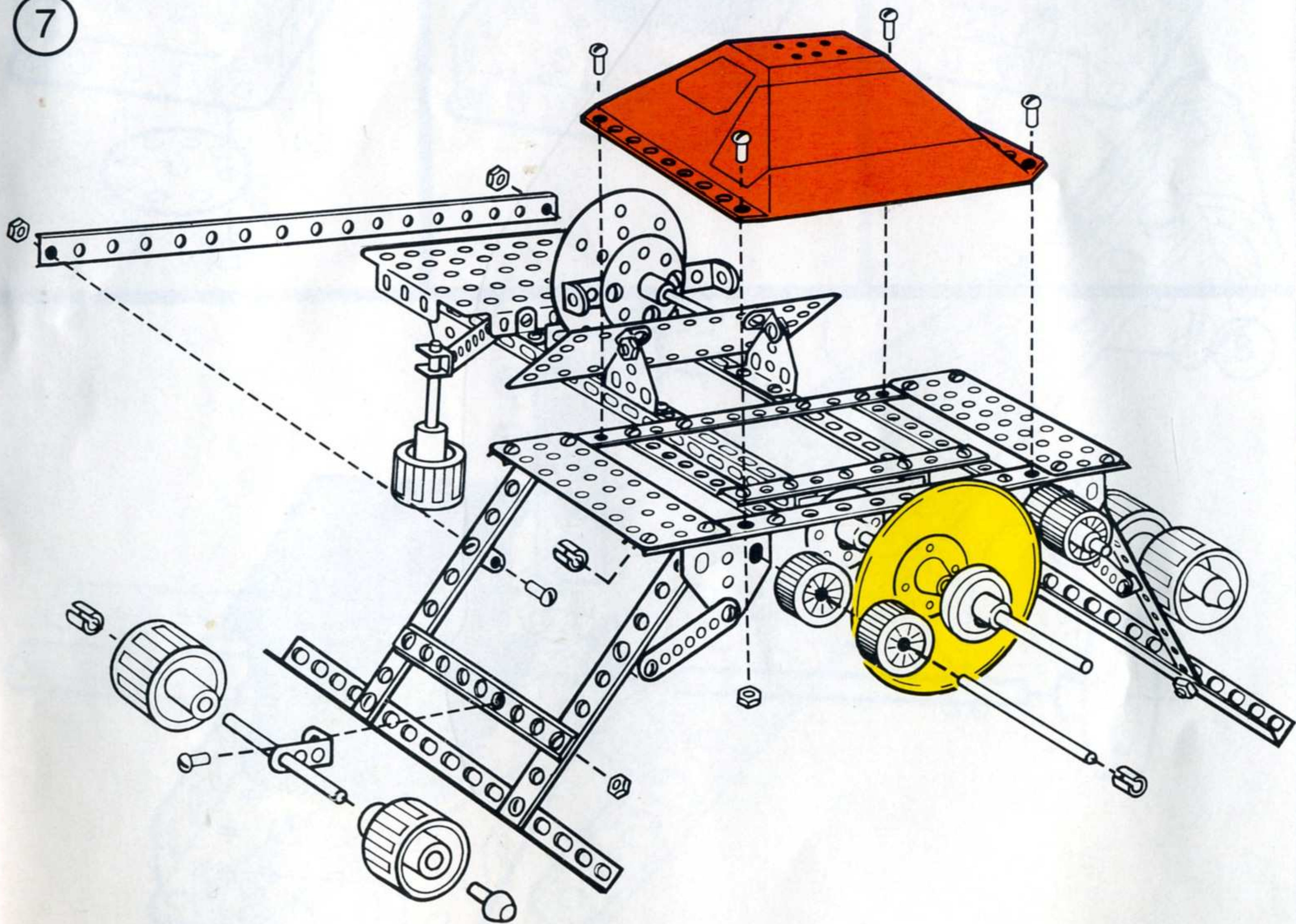

9

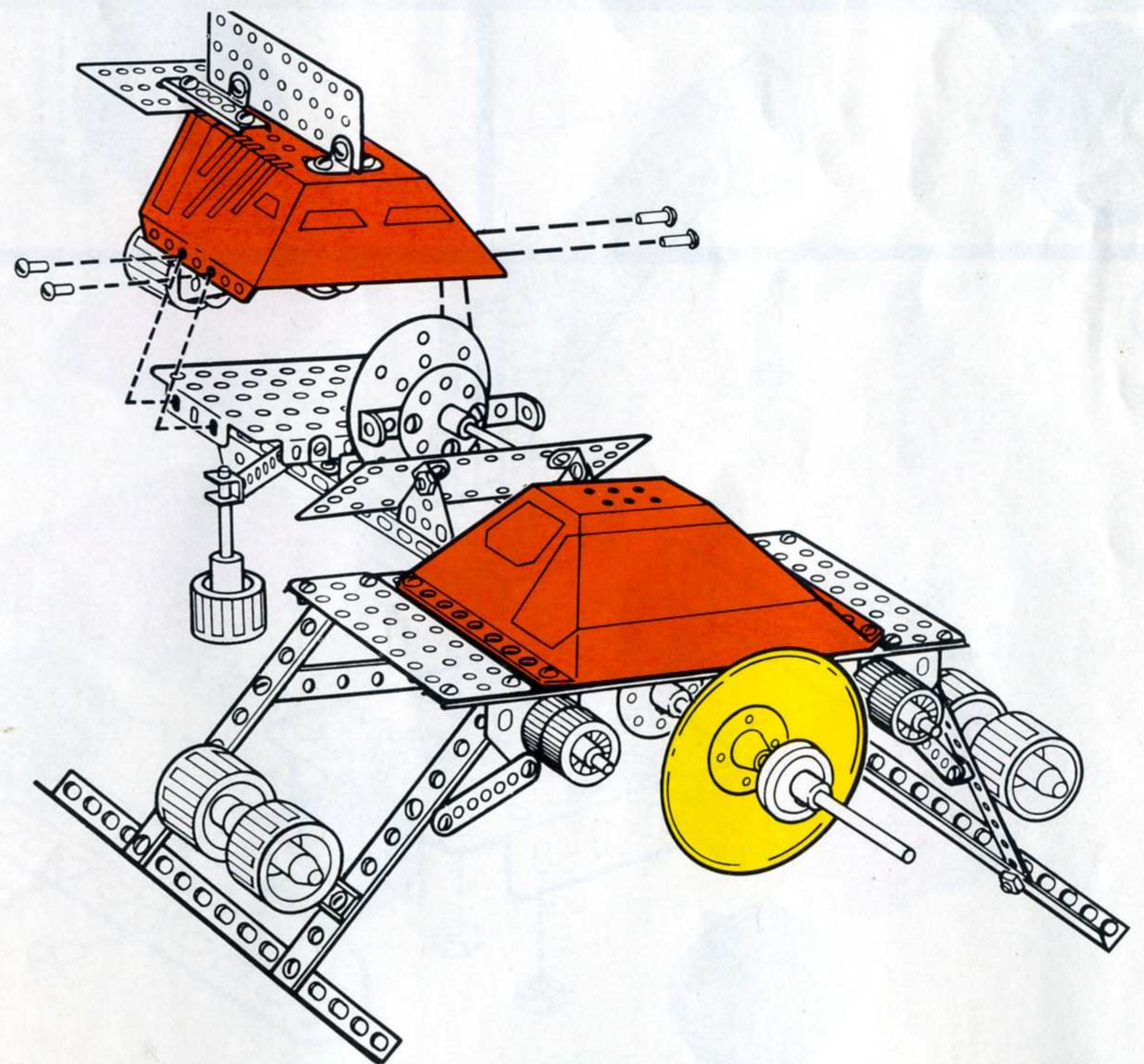



# MINING LOADER

1

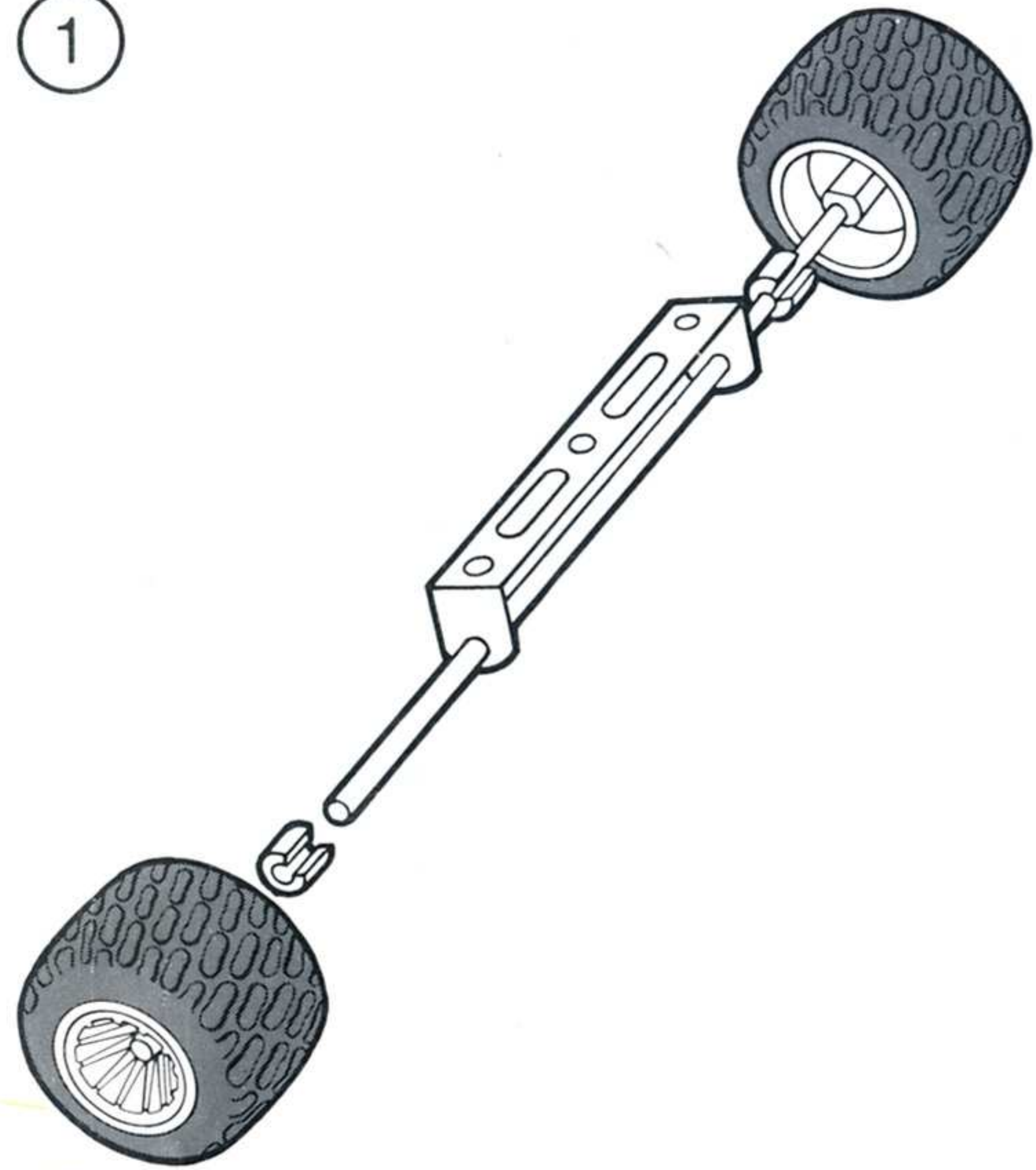

2

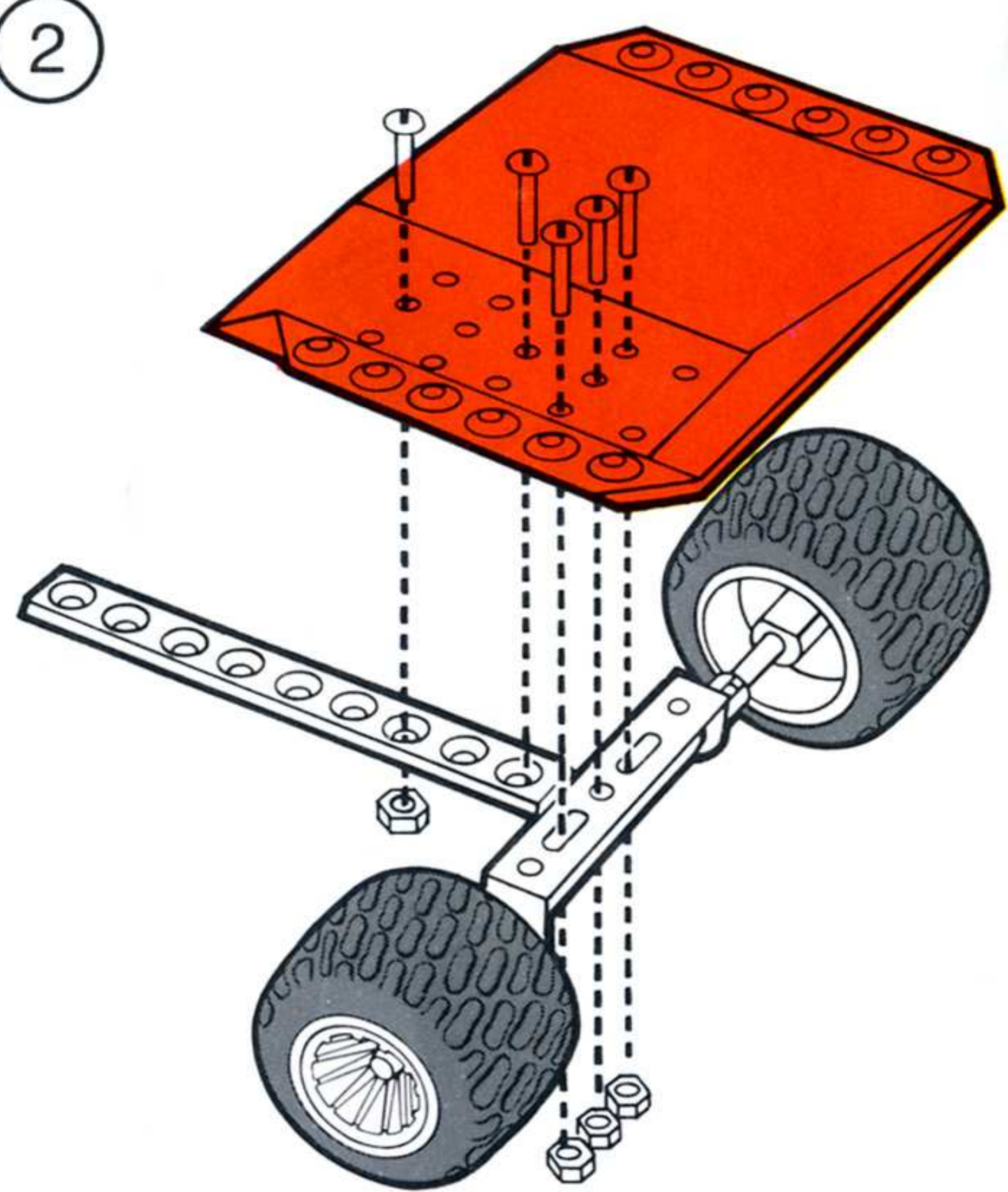

3

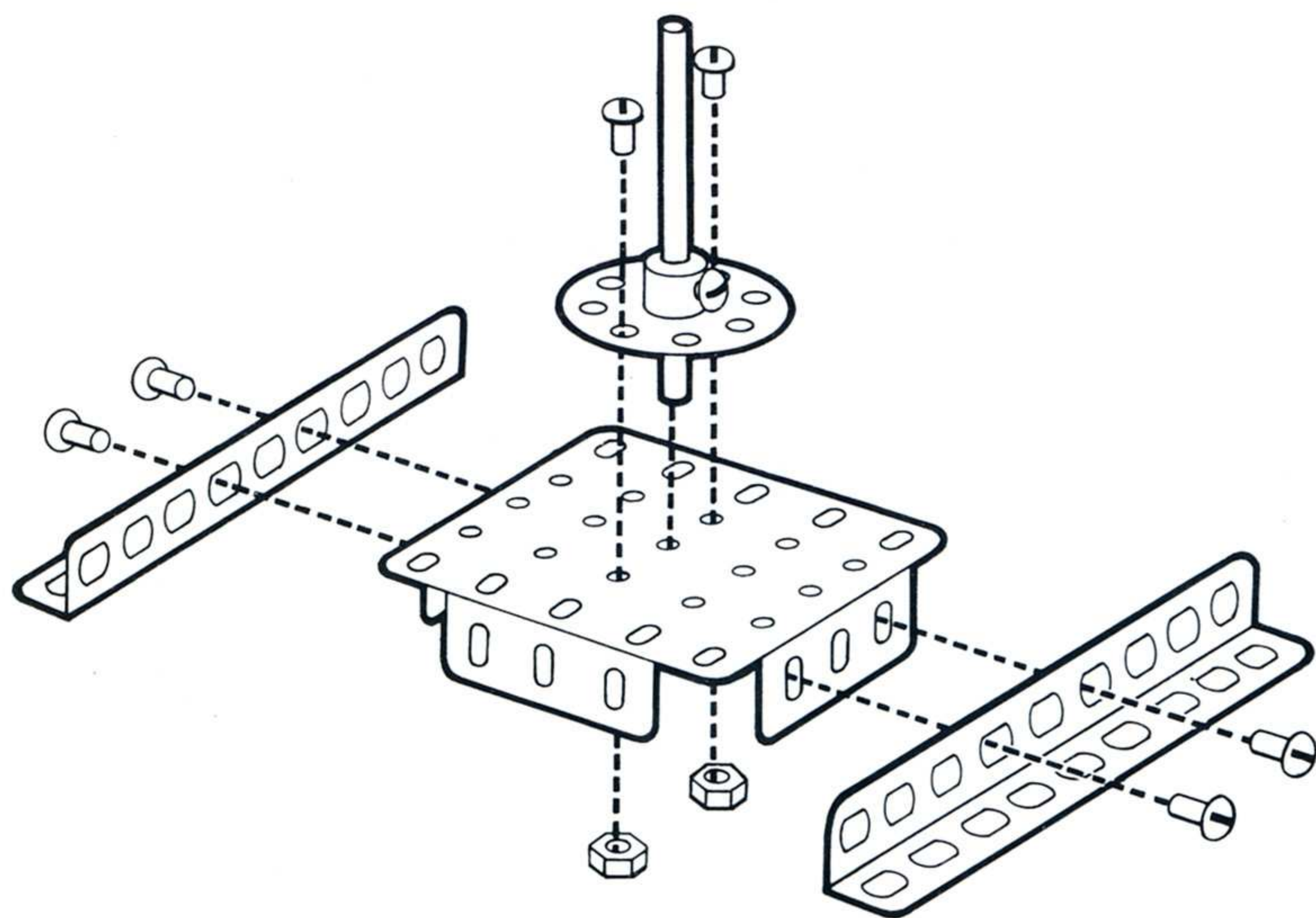

4

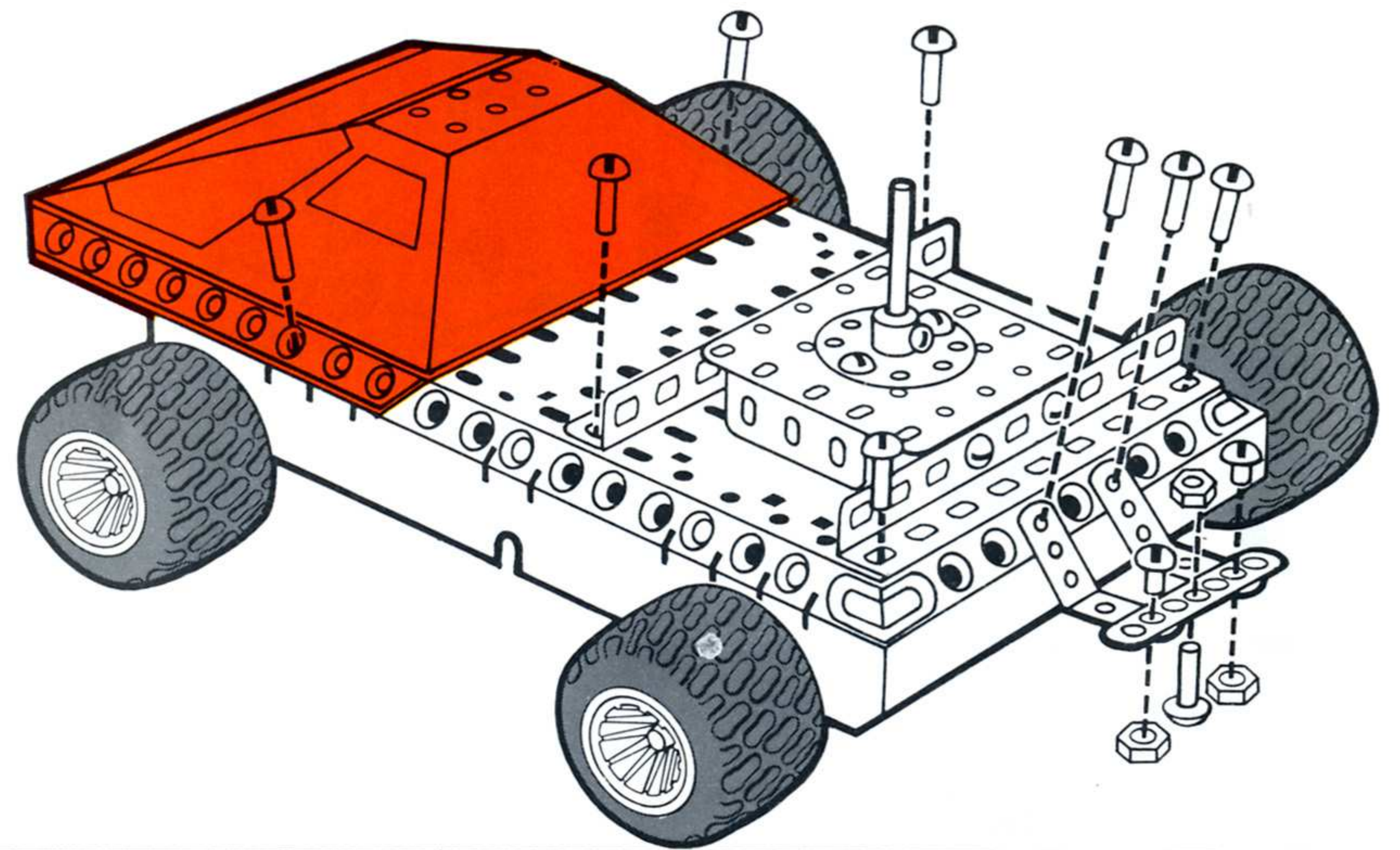

5

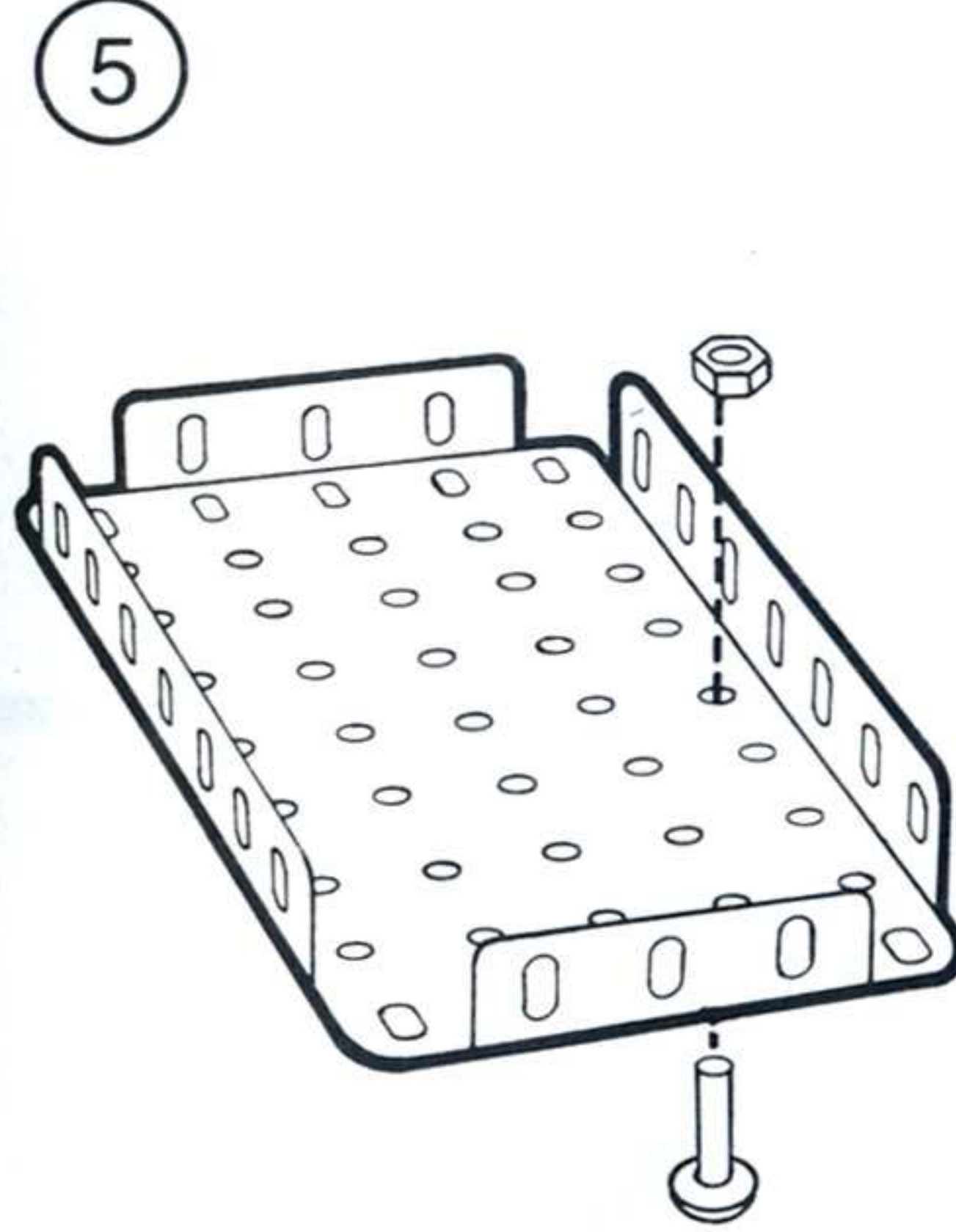

6

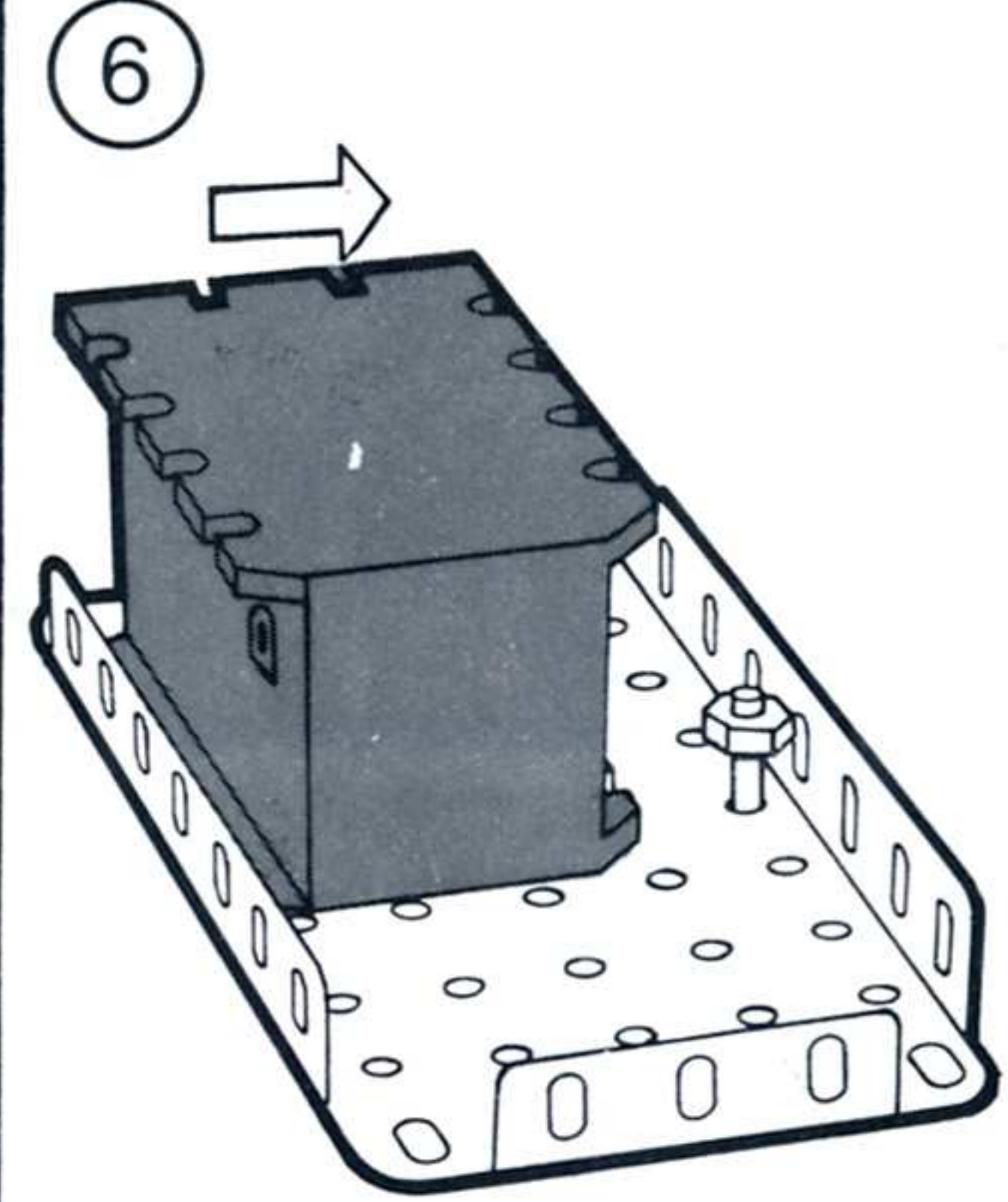

7

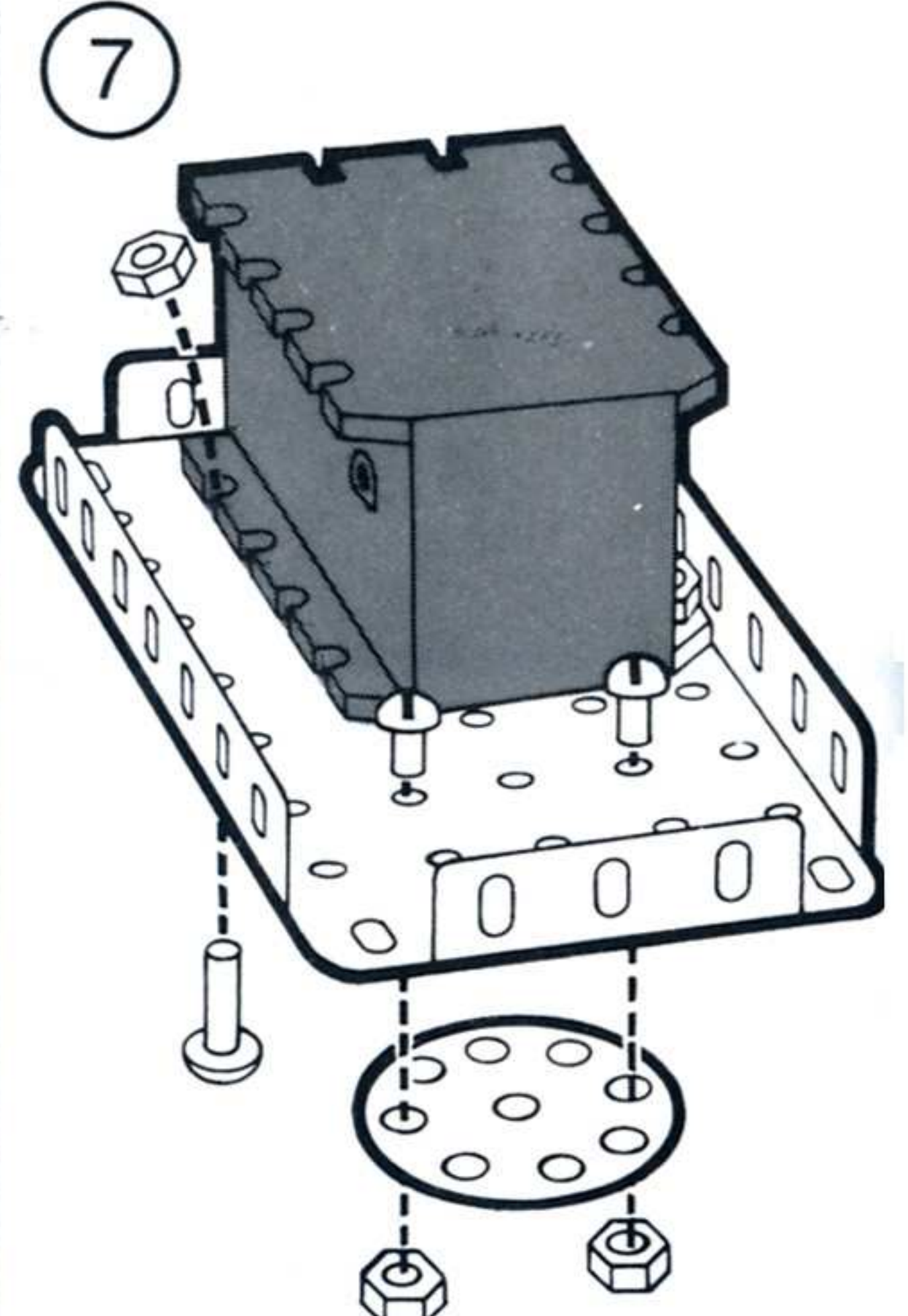

8

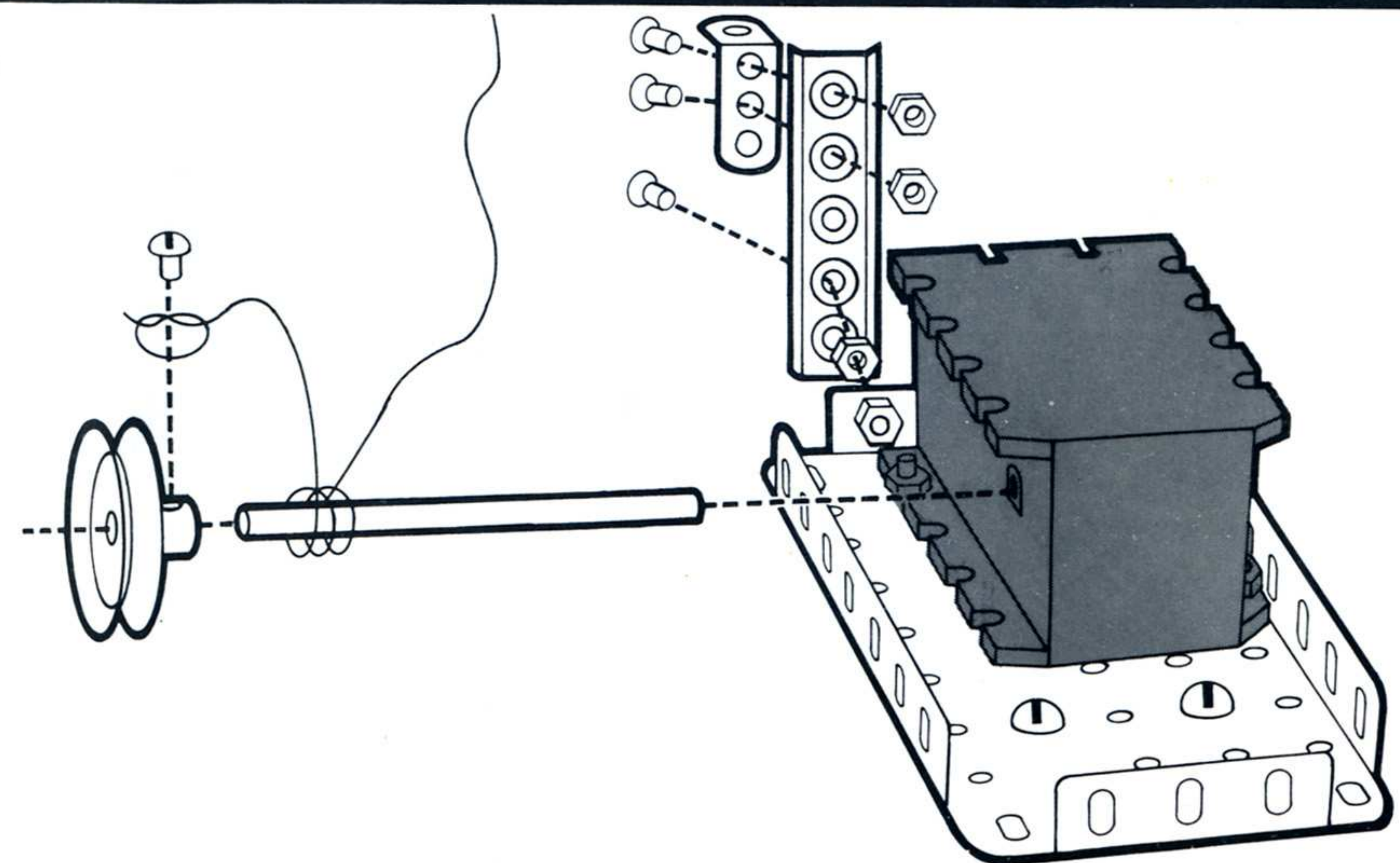



9

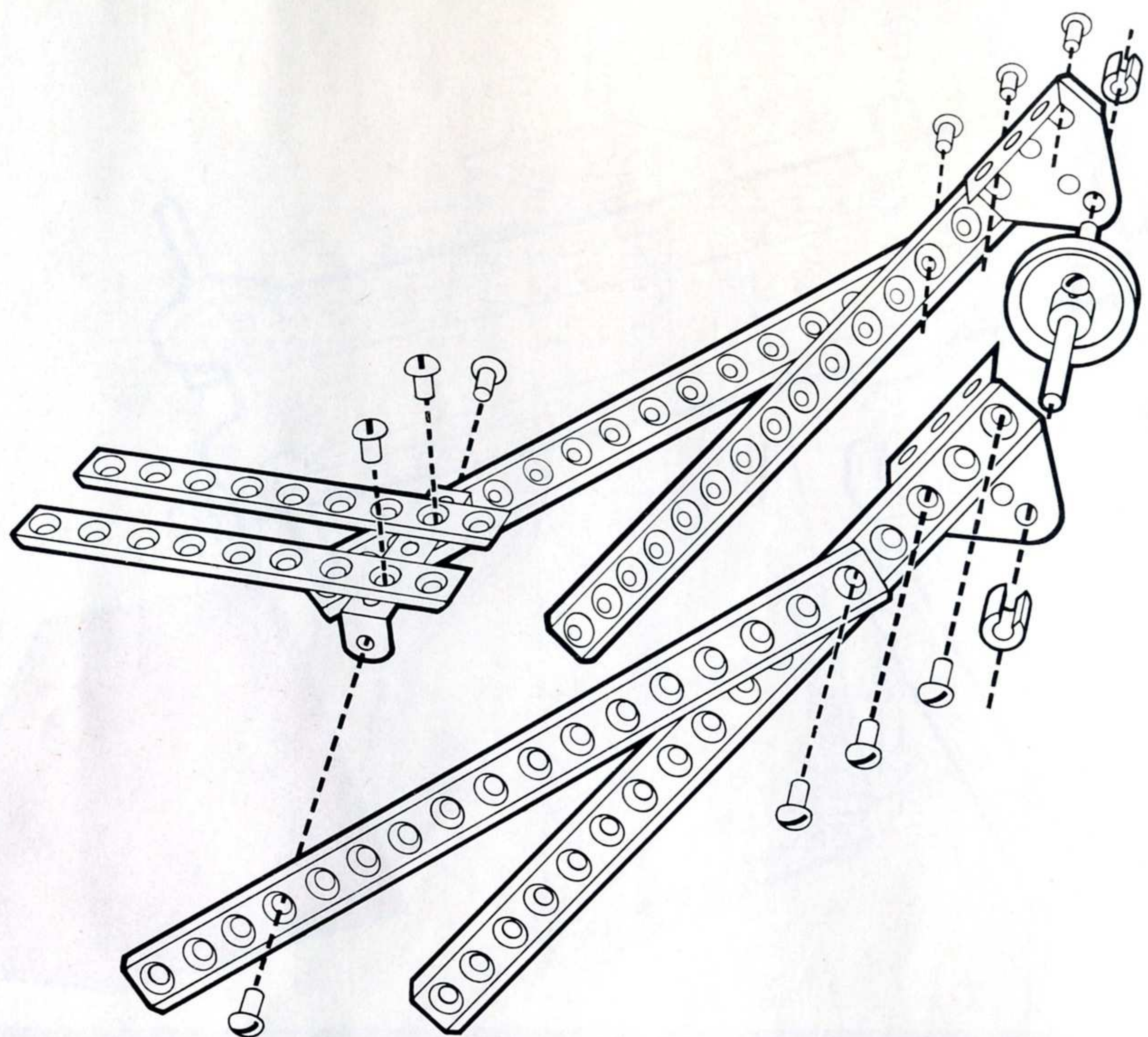

11

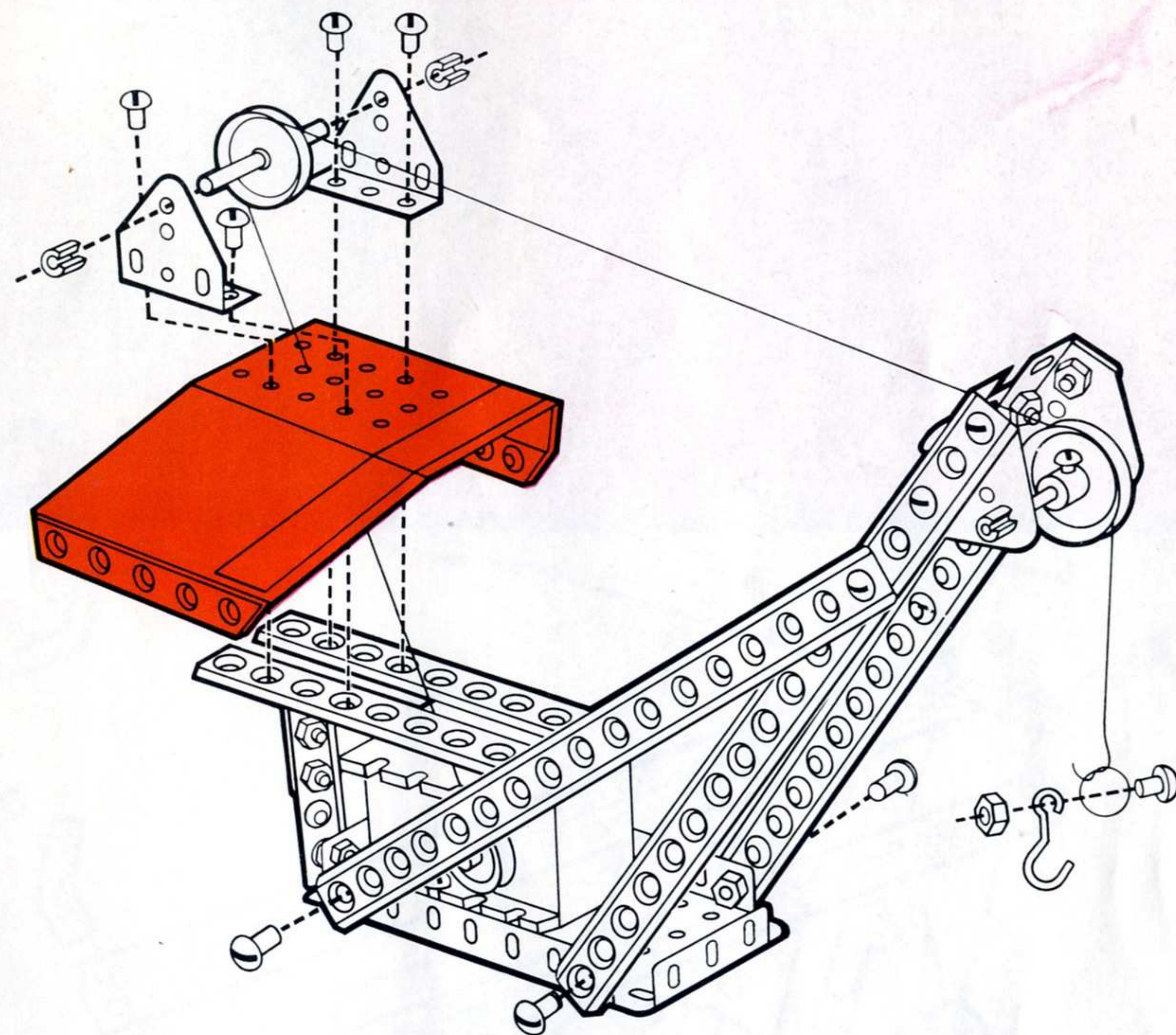

10

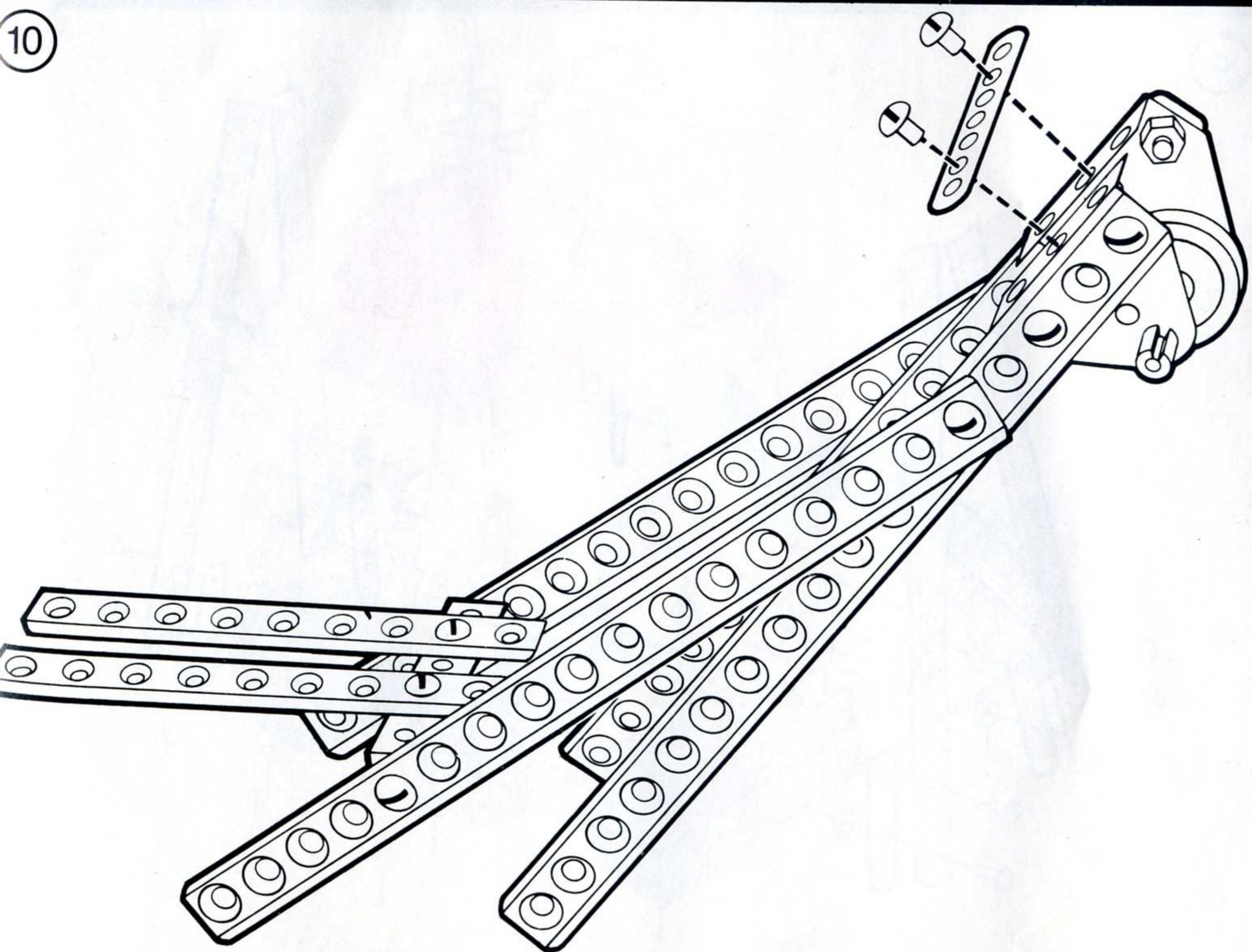

12

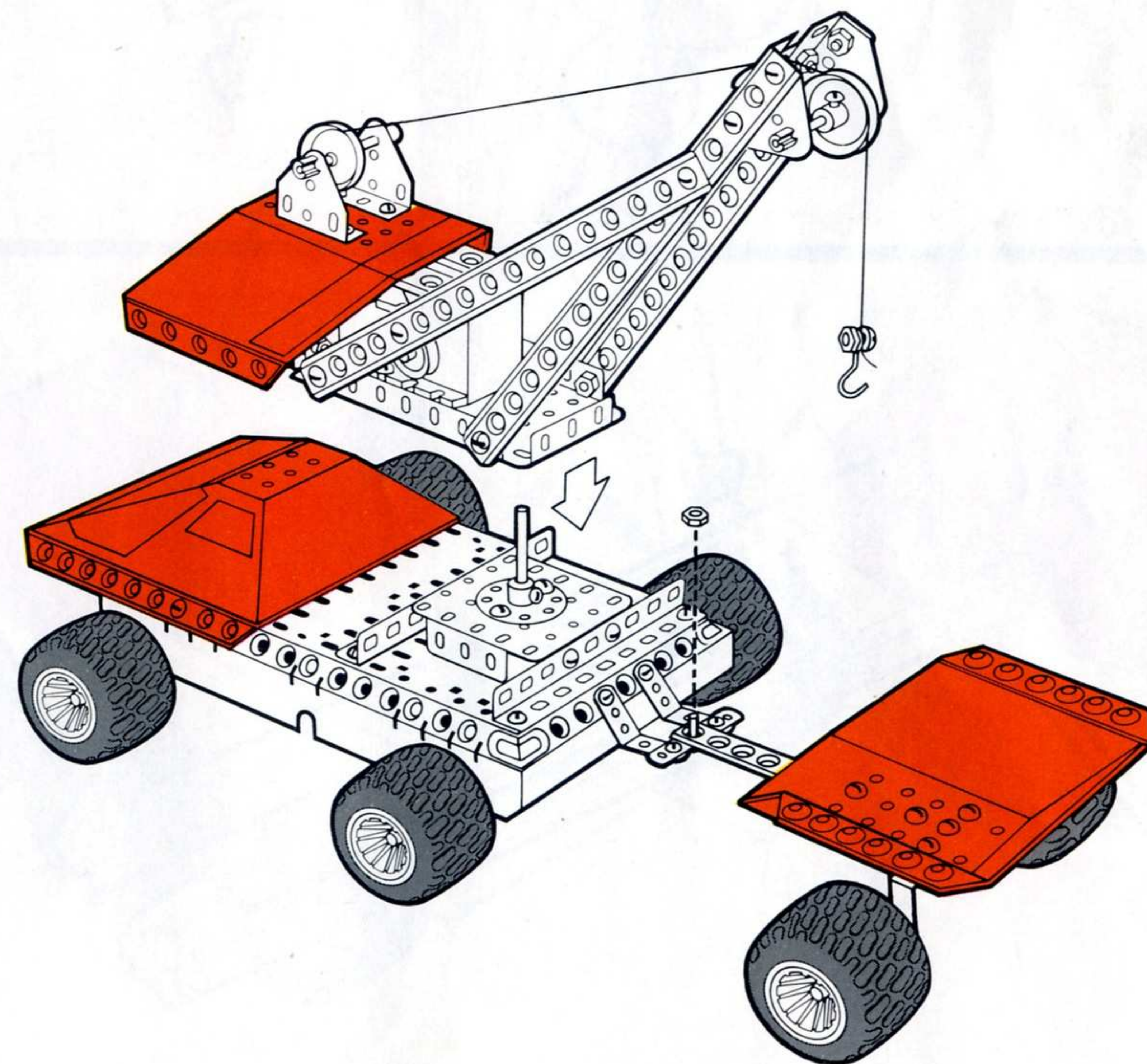



# MOBILE CARRIER



1

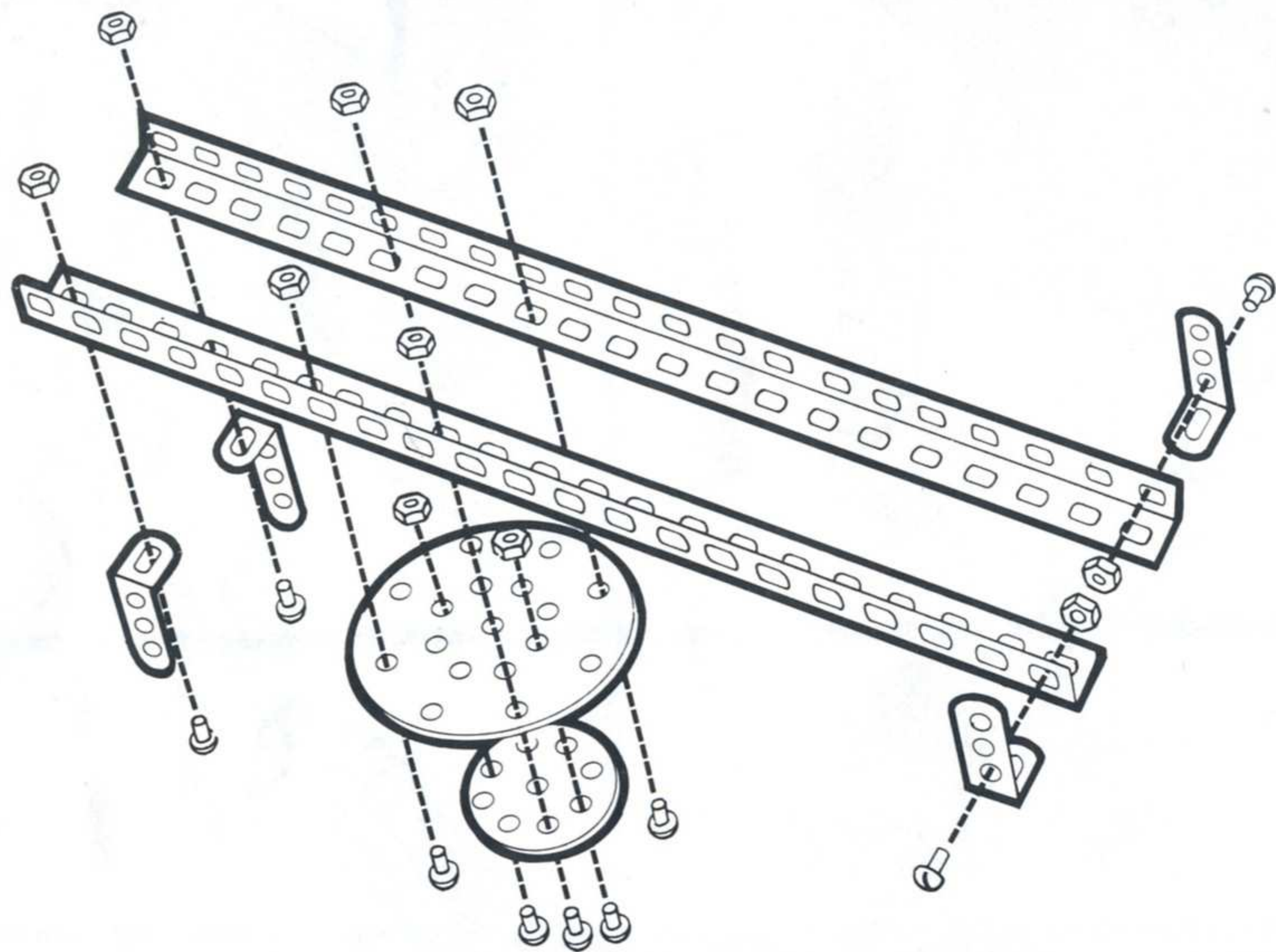

2

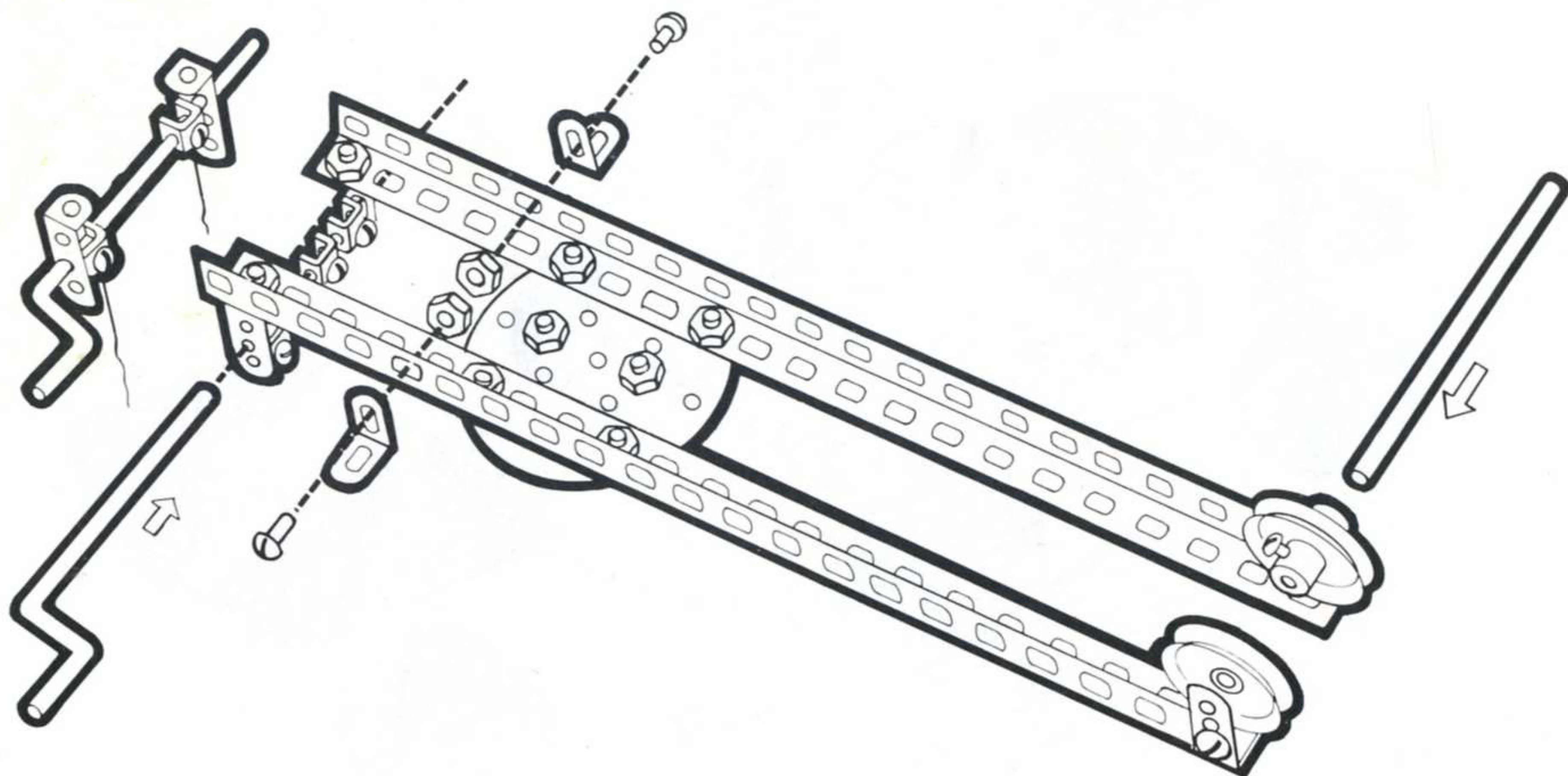

3

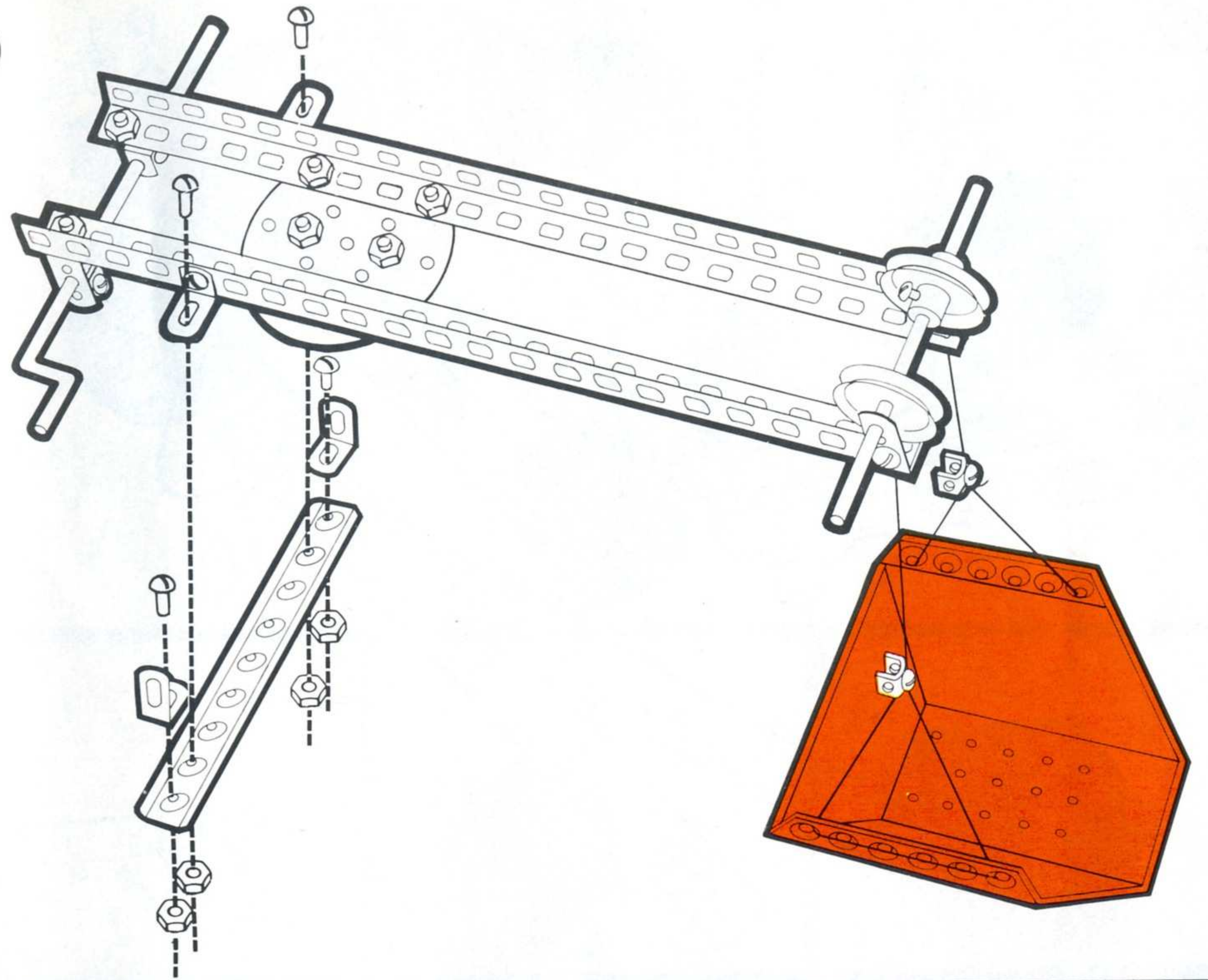

4

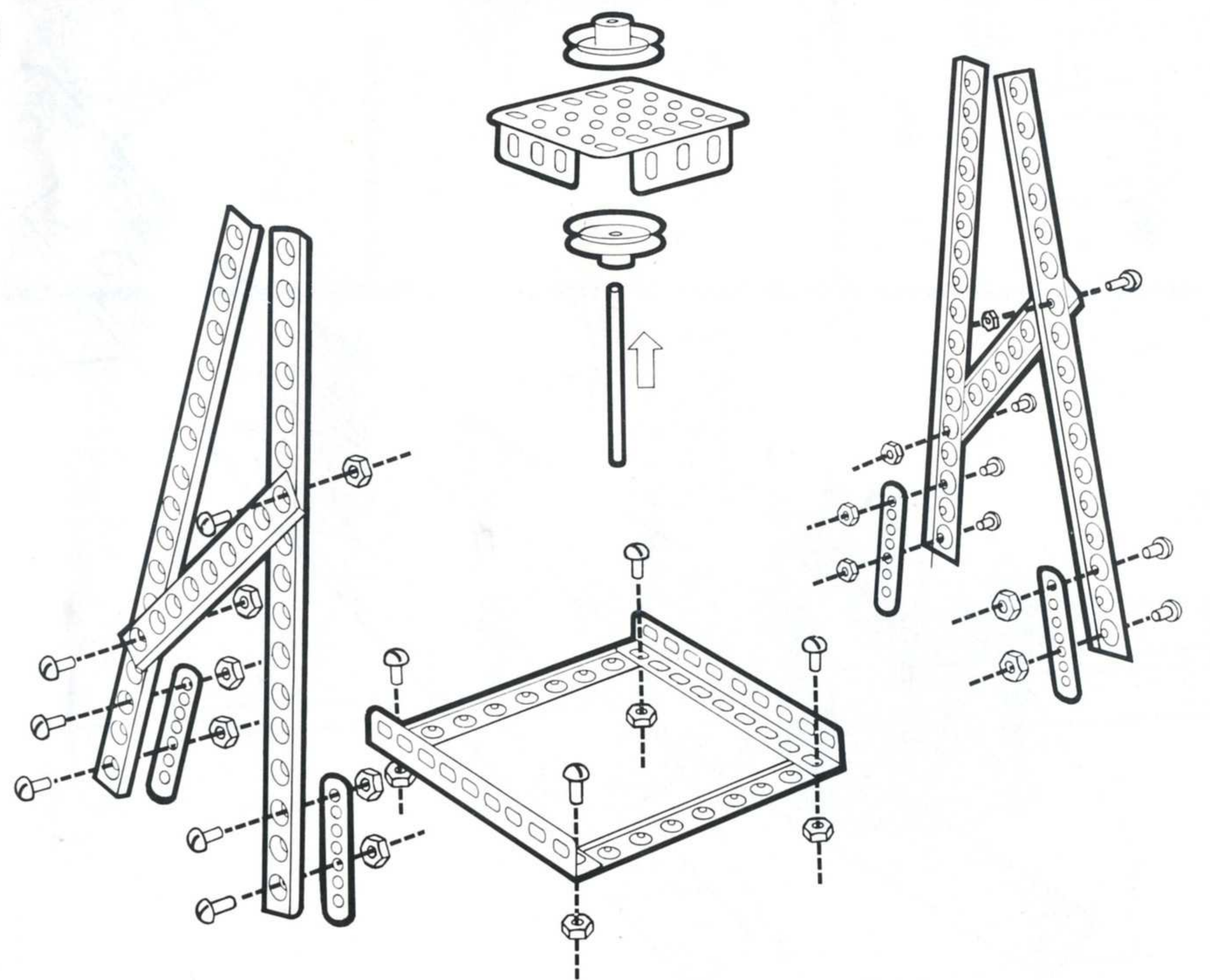



5

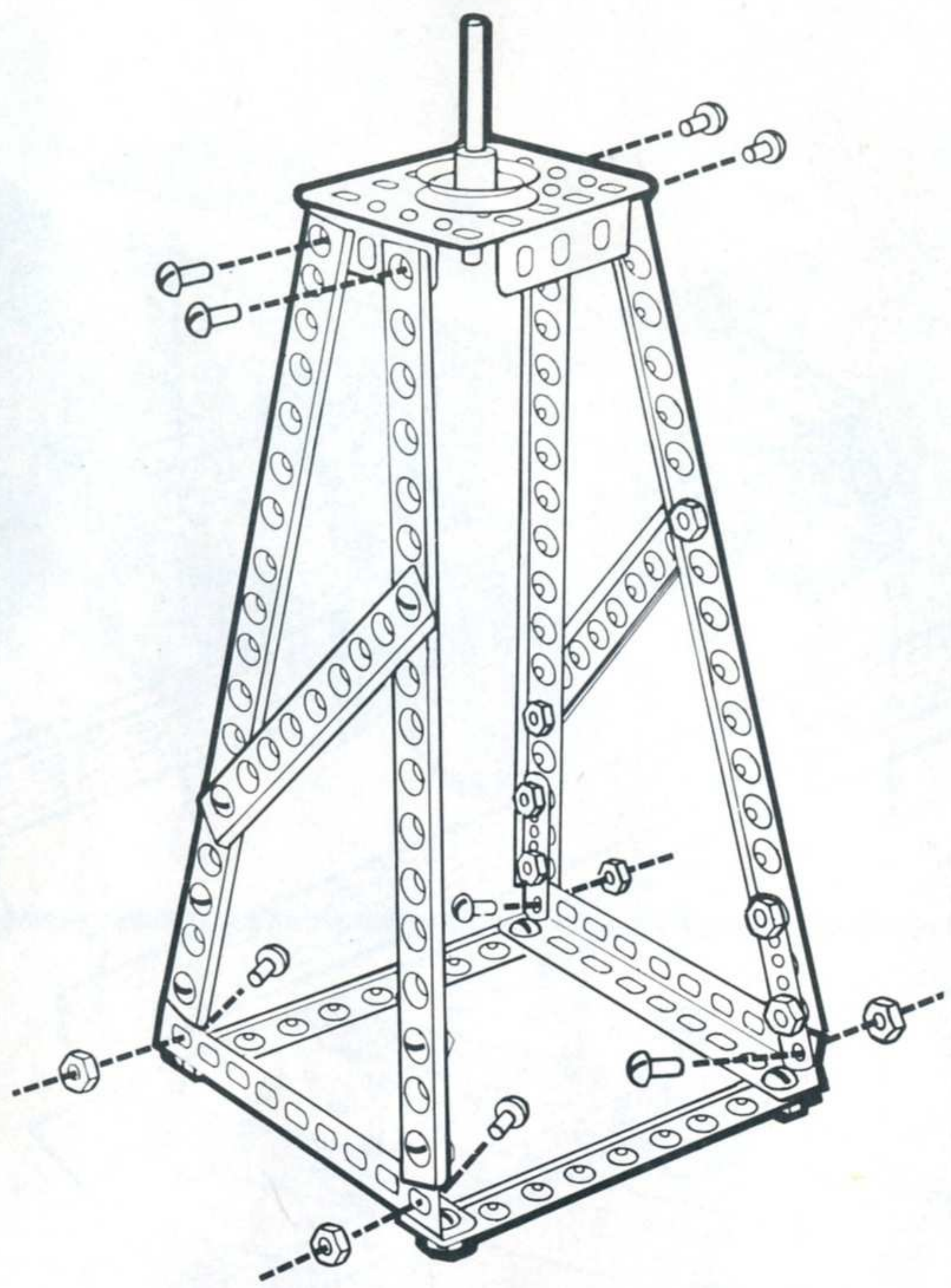

6

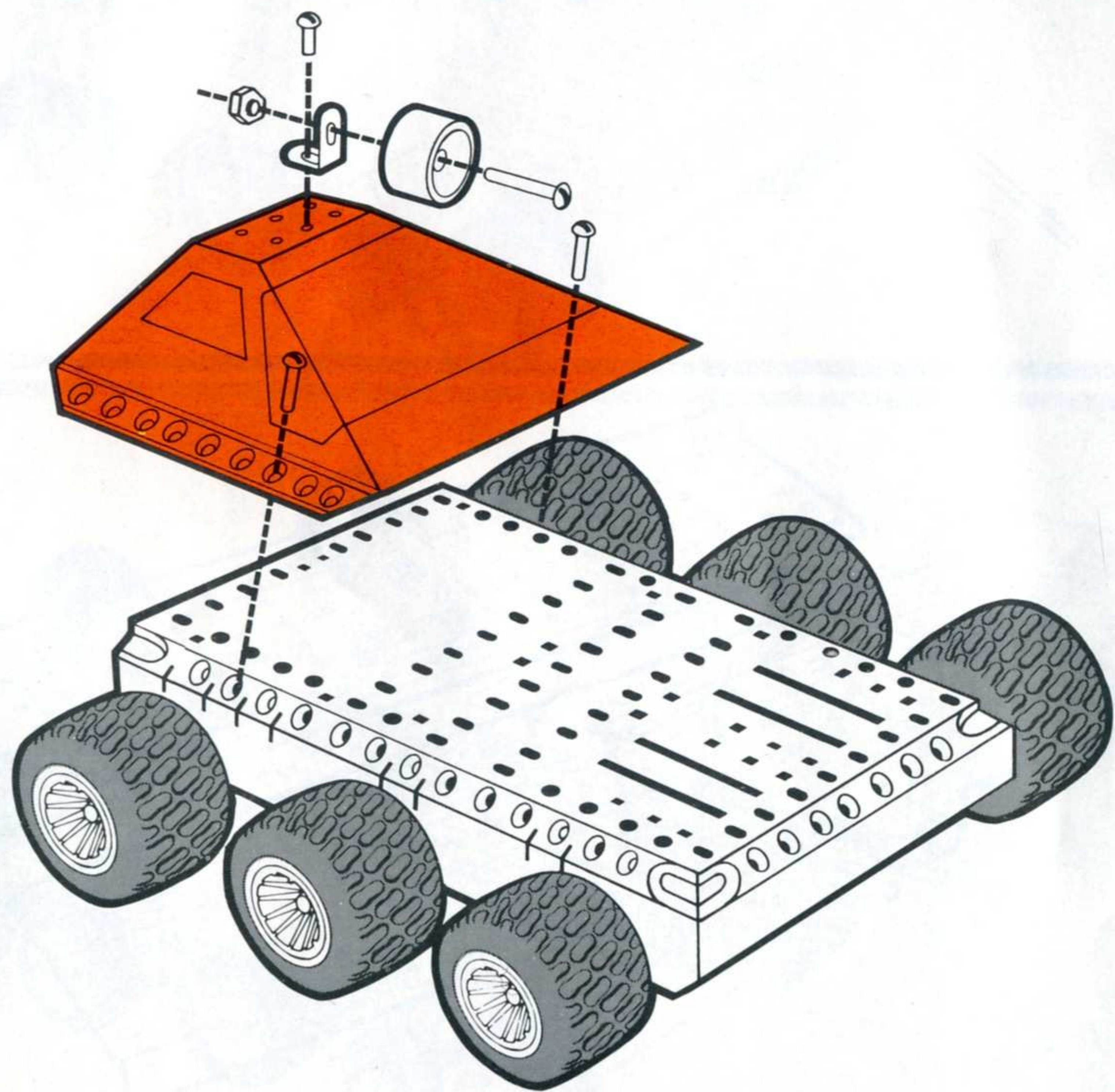

7

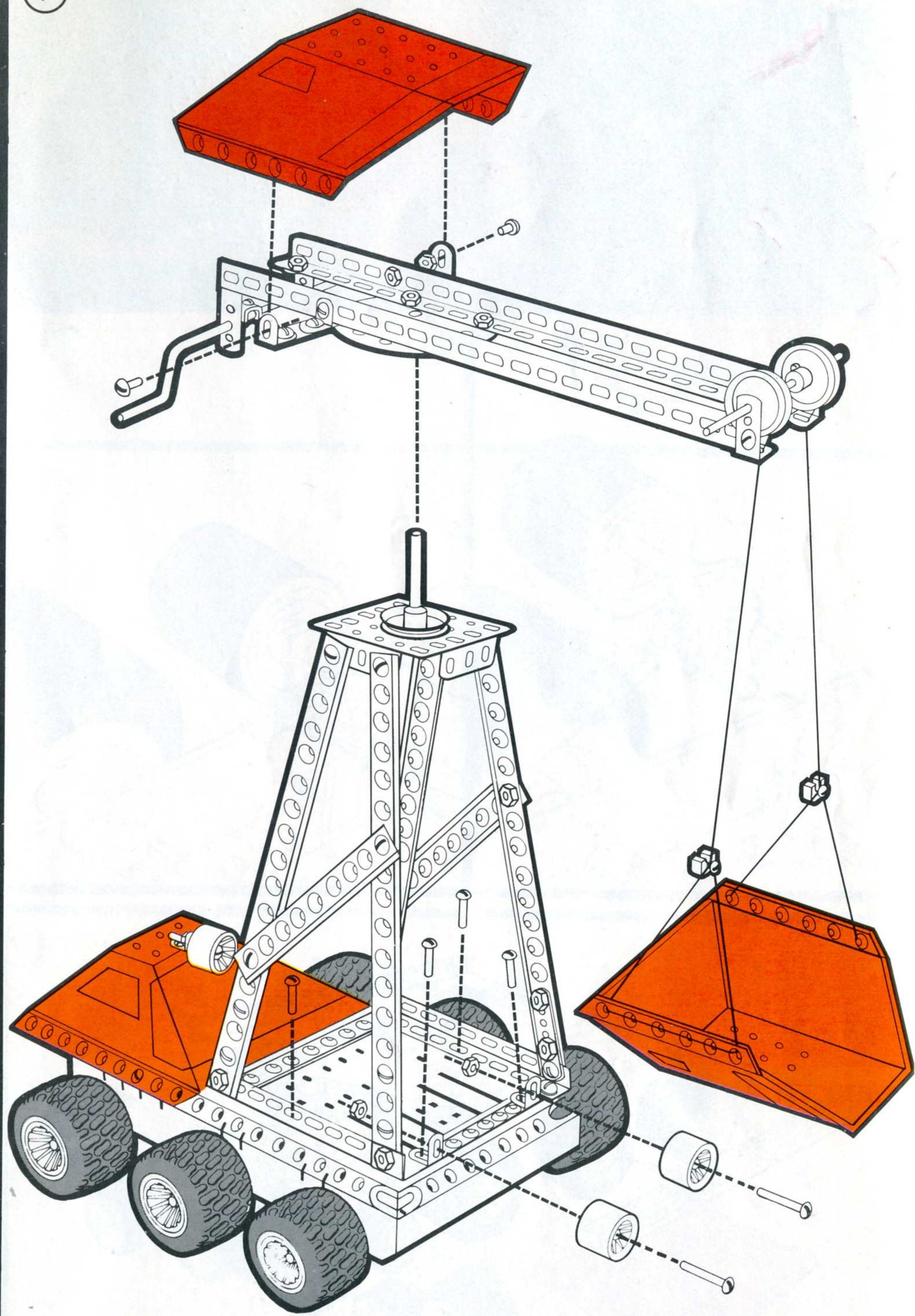



# RADAR TANK



4

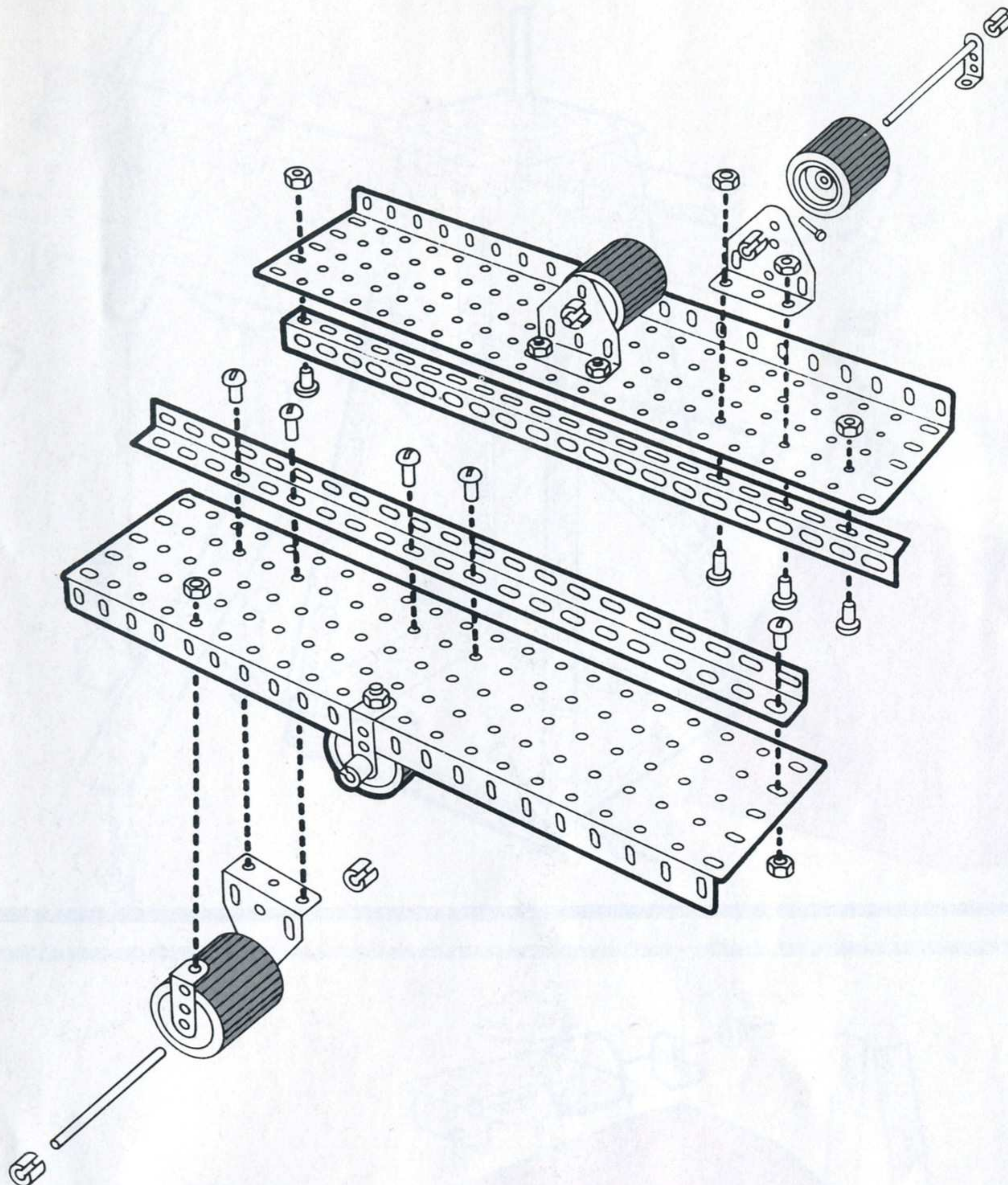

1

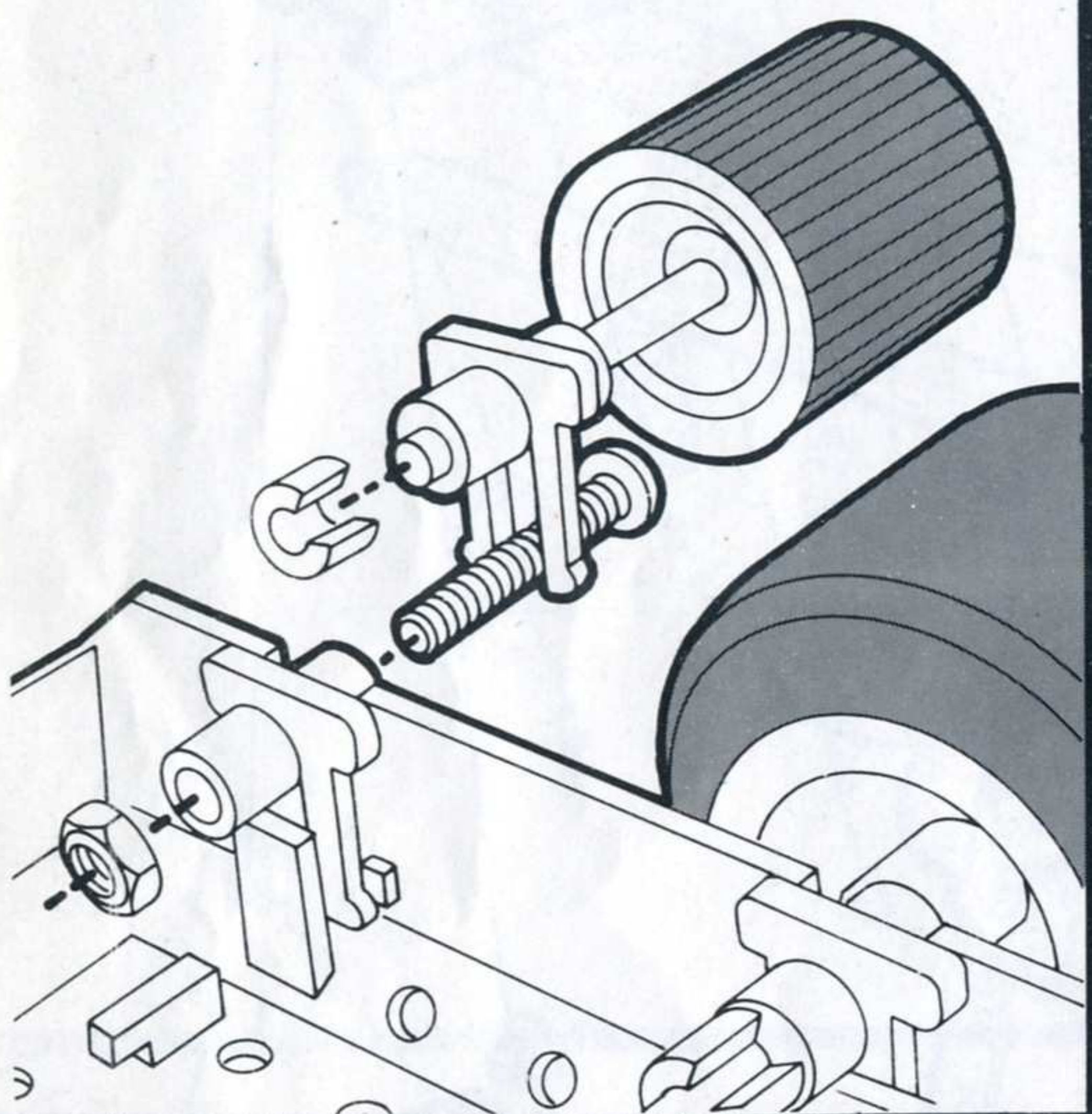

2

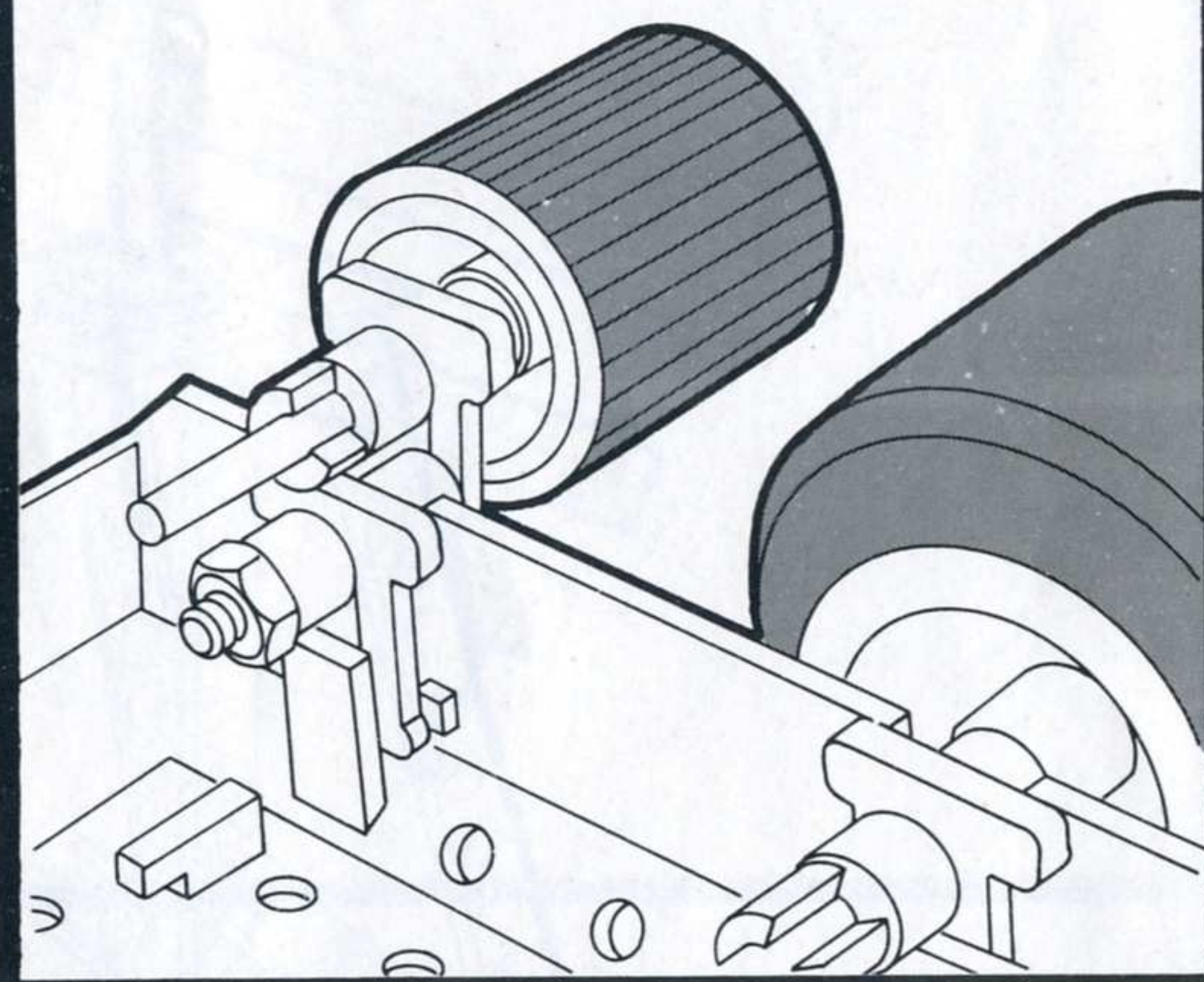

3

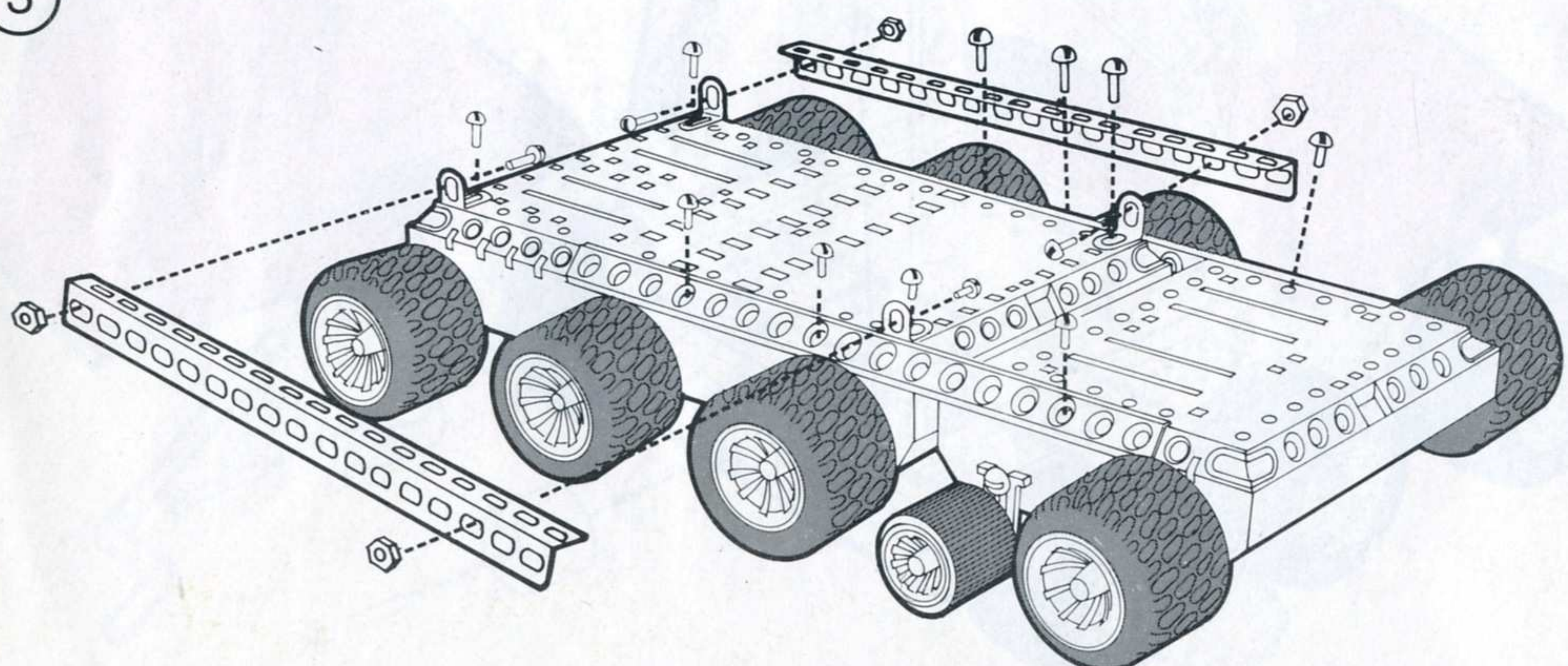

5

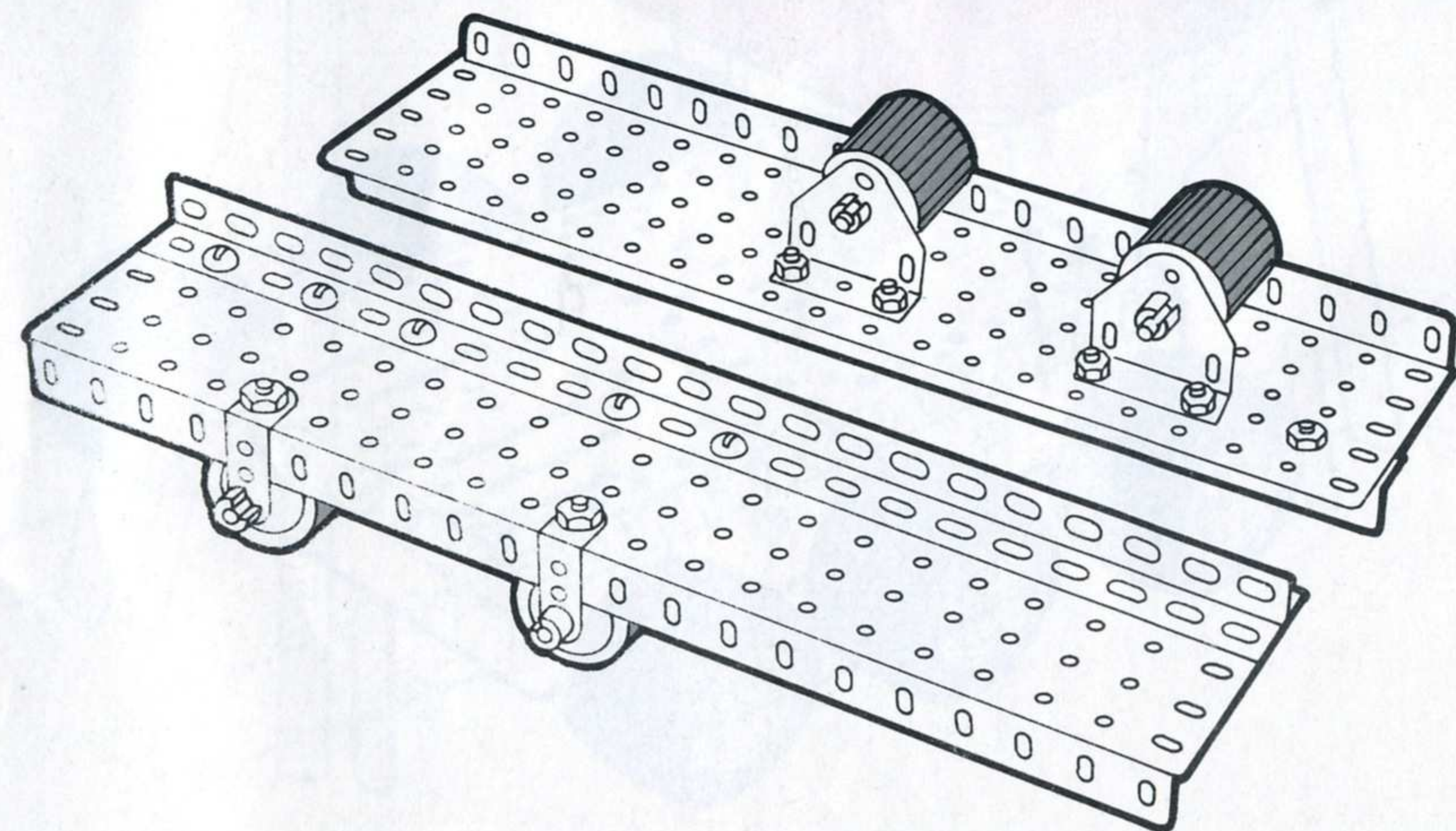



6

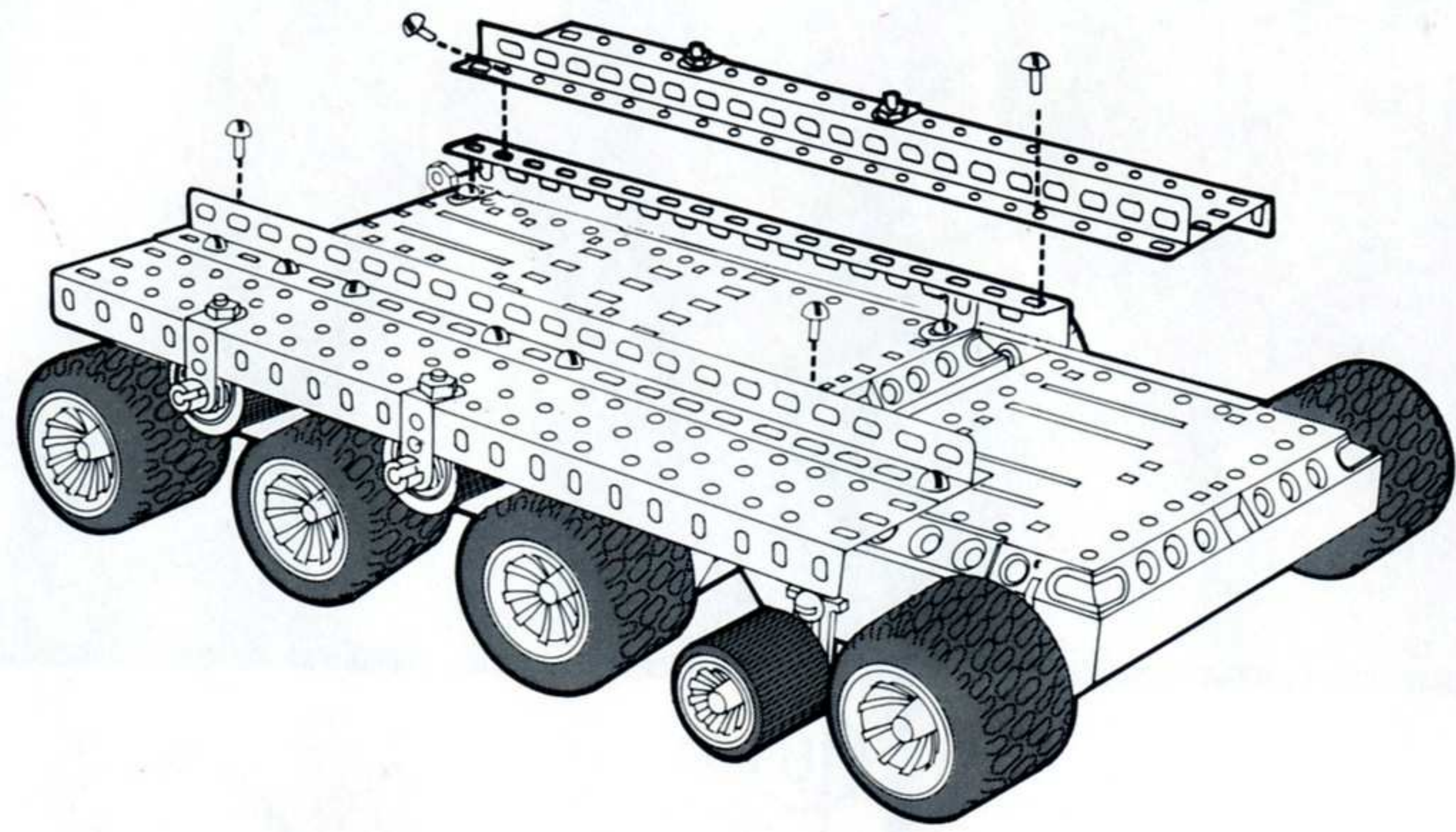

9

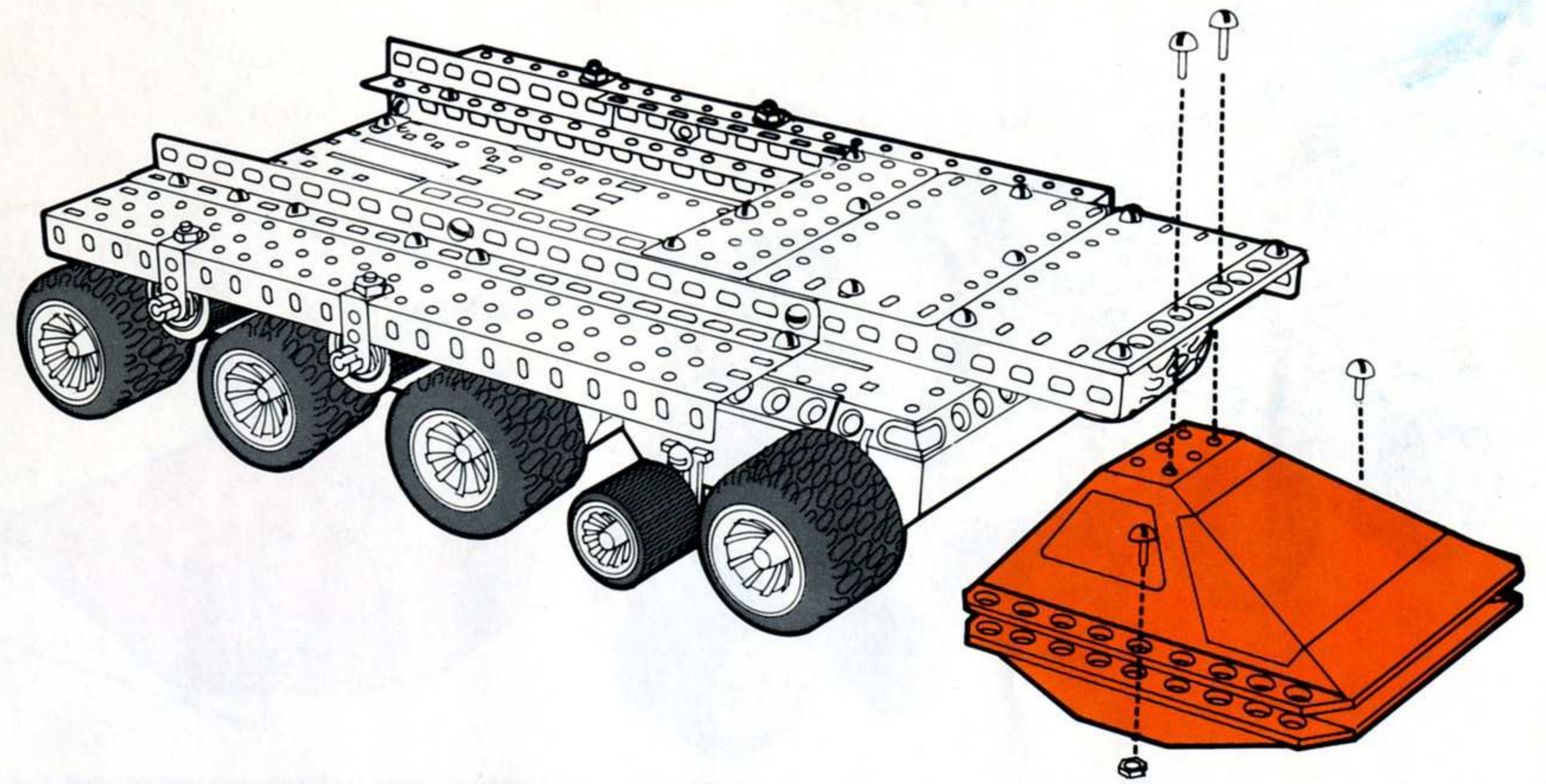

7

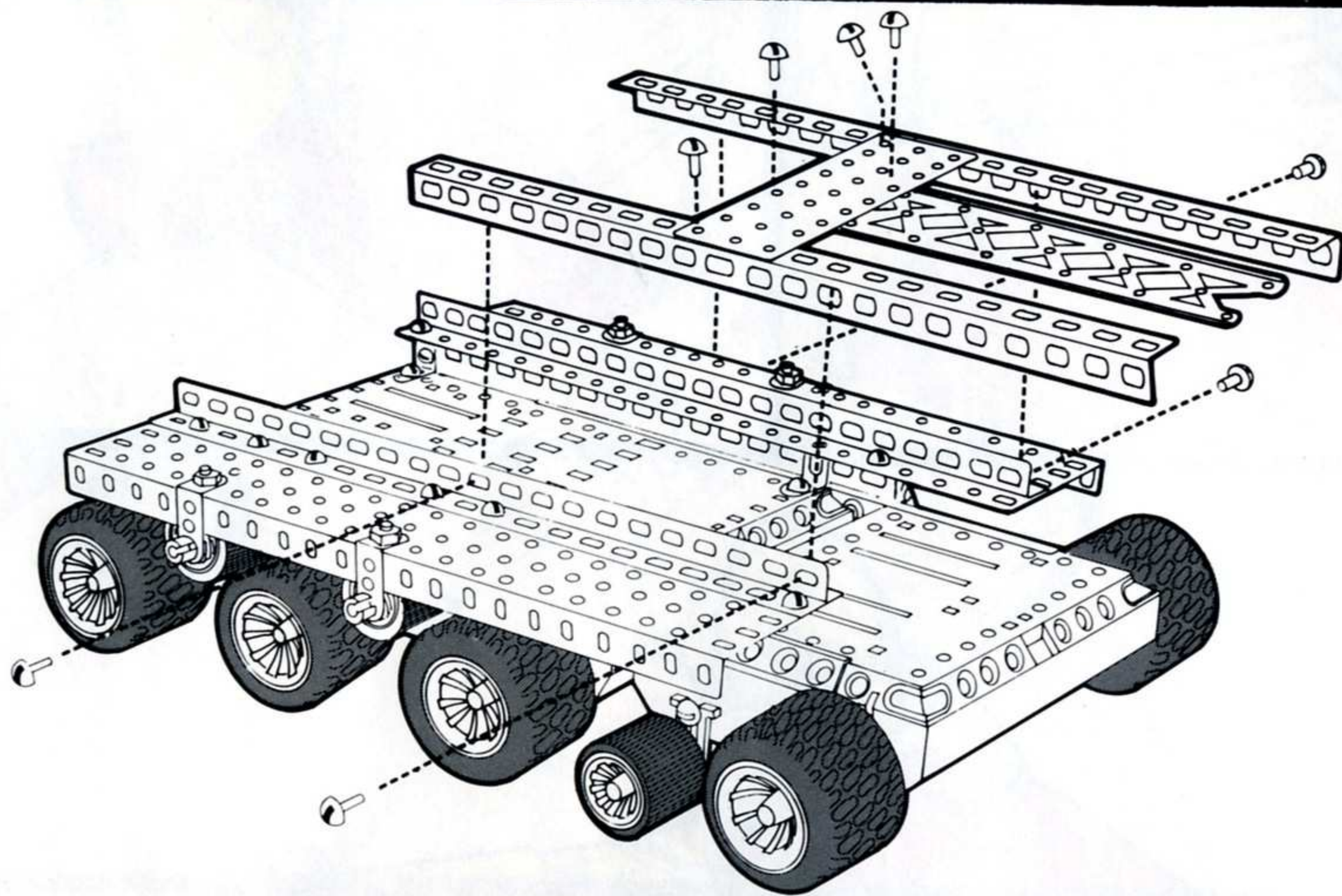

10

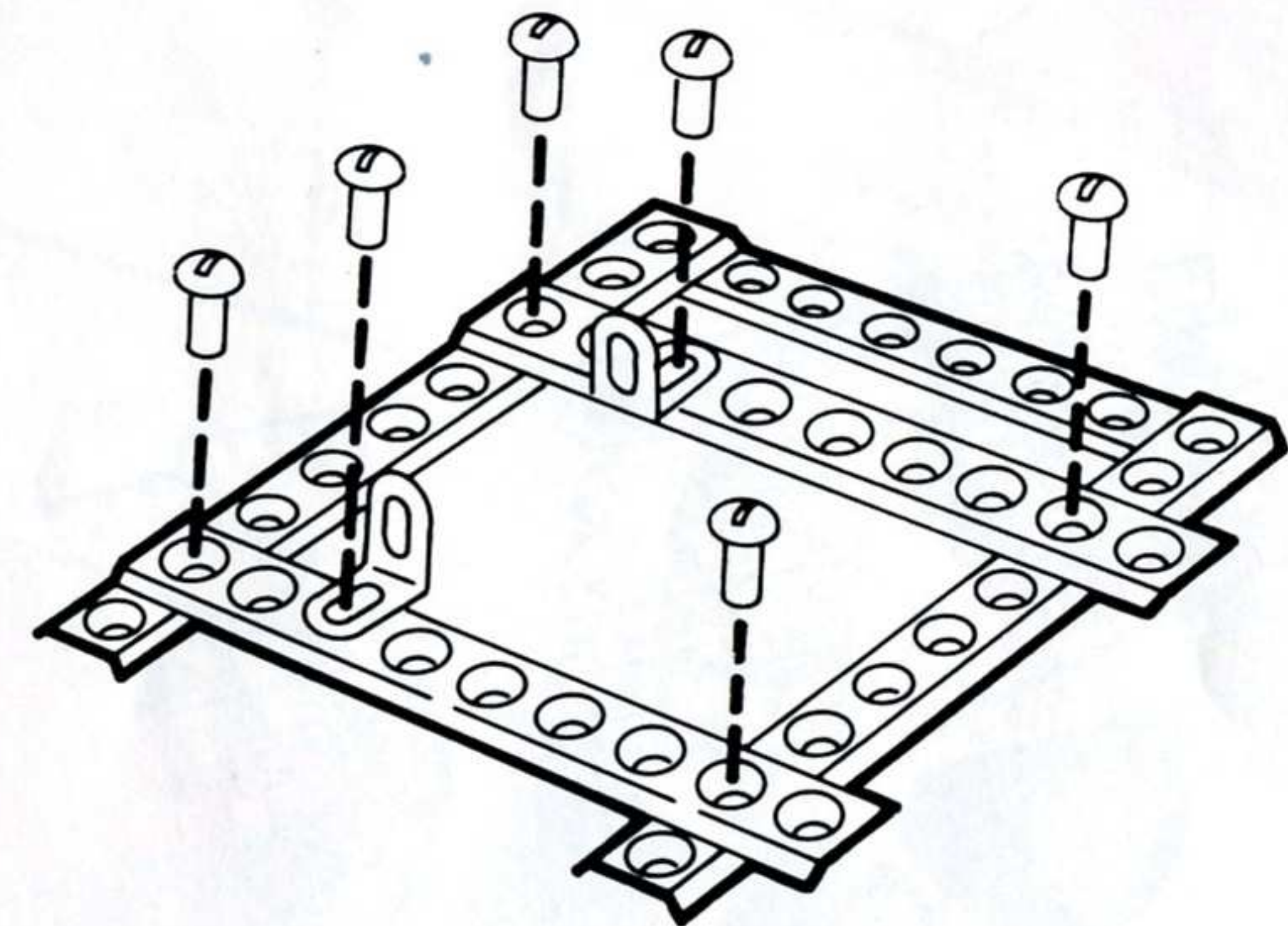

8

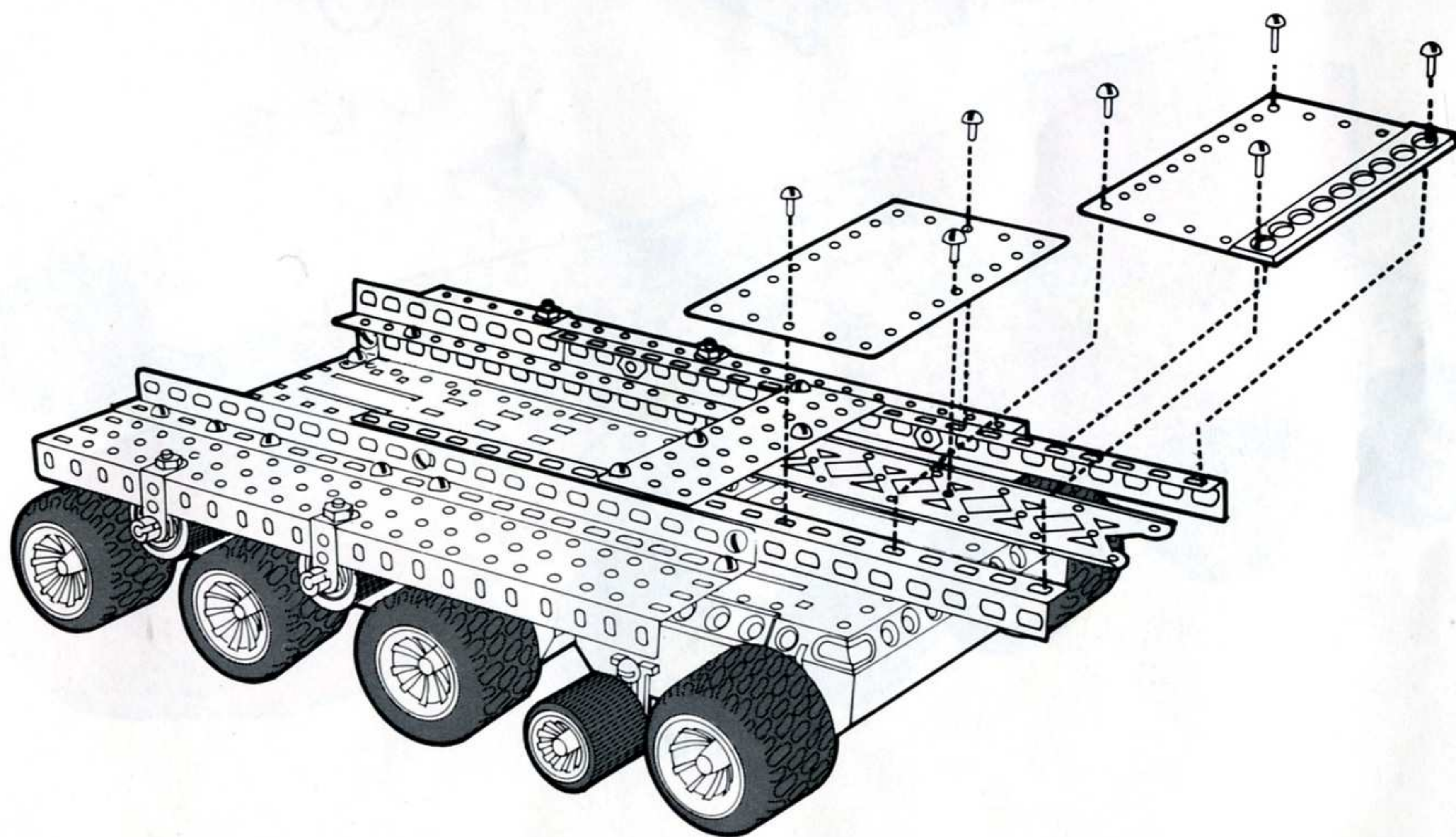

11

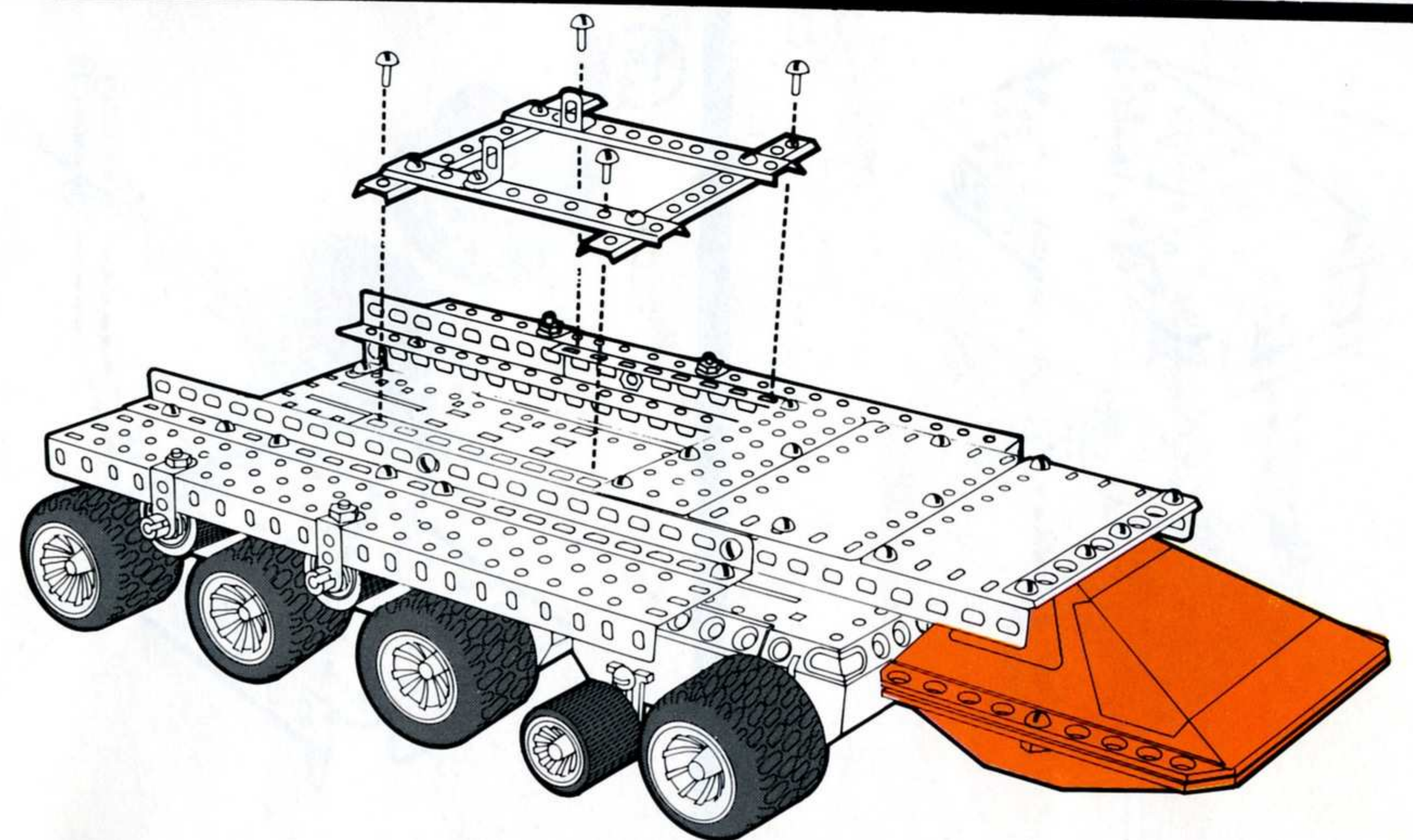



12

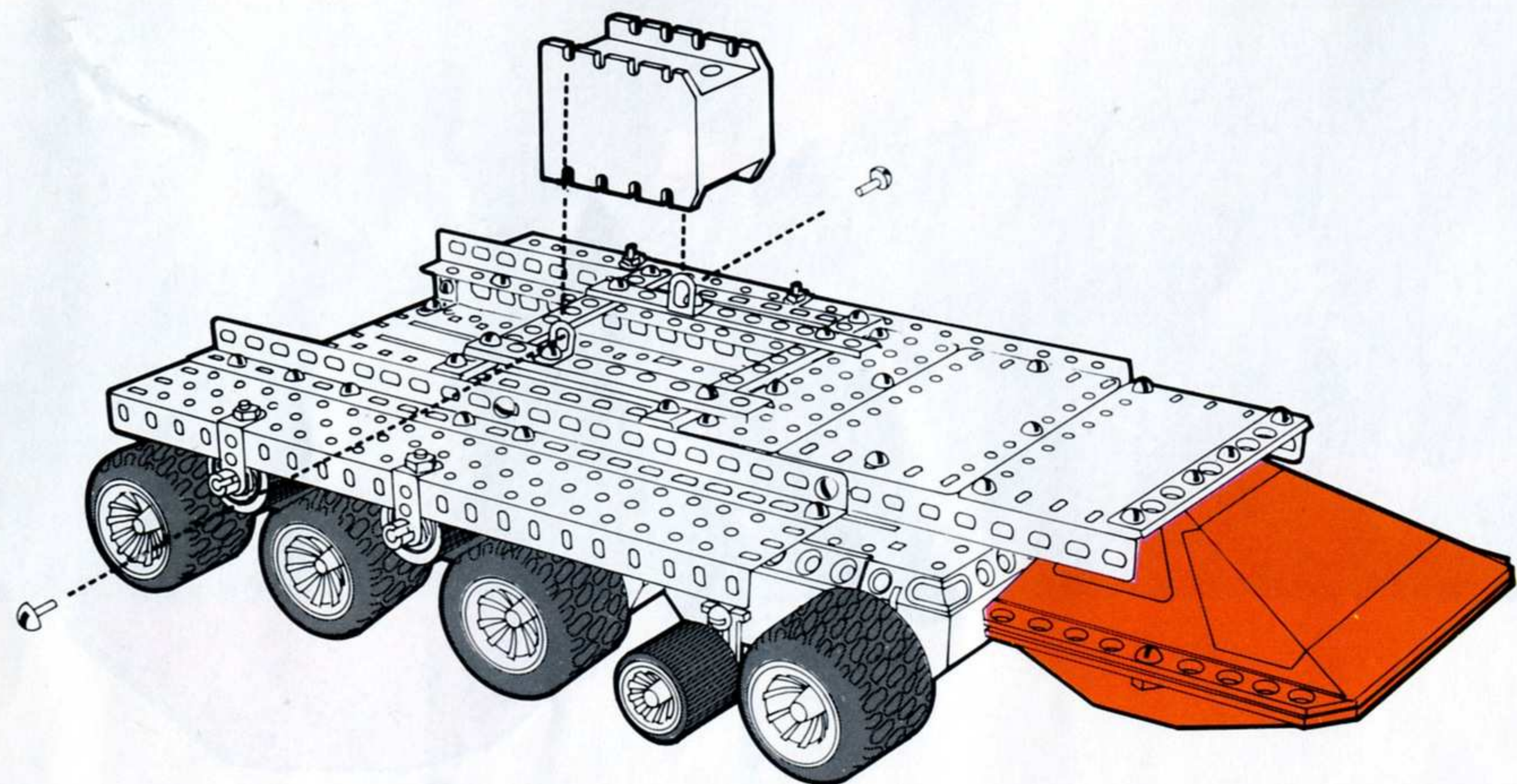

16

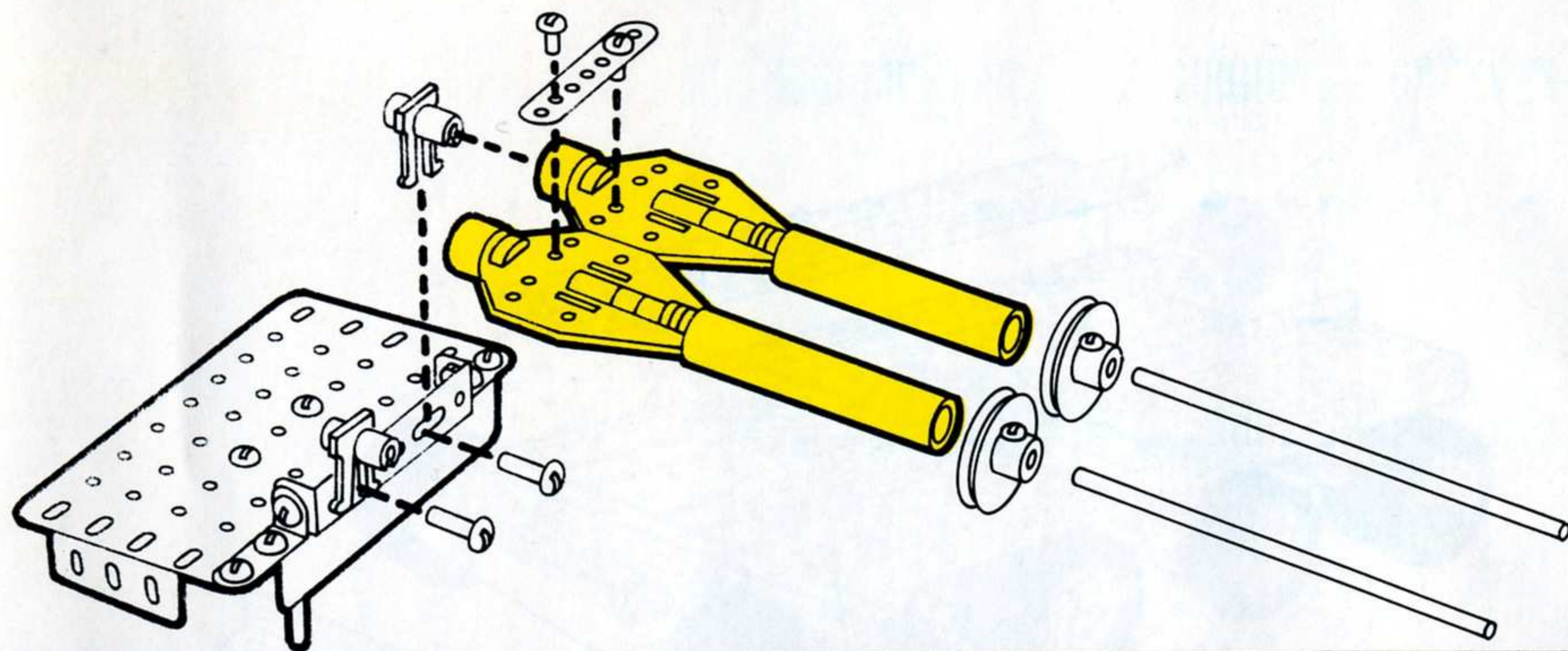

13

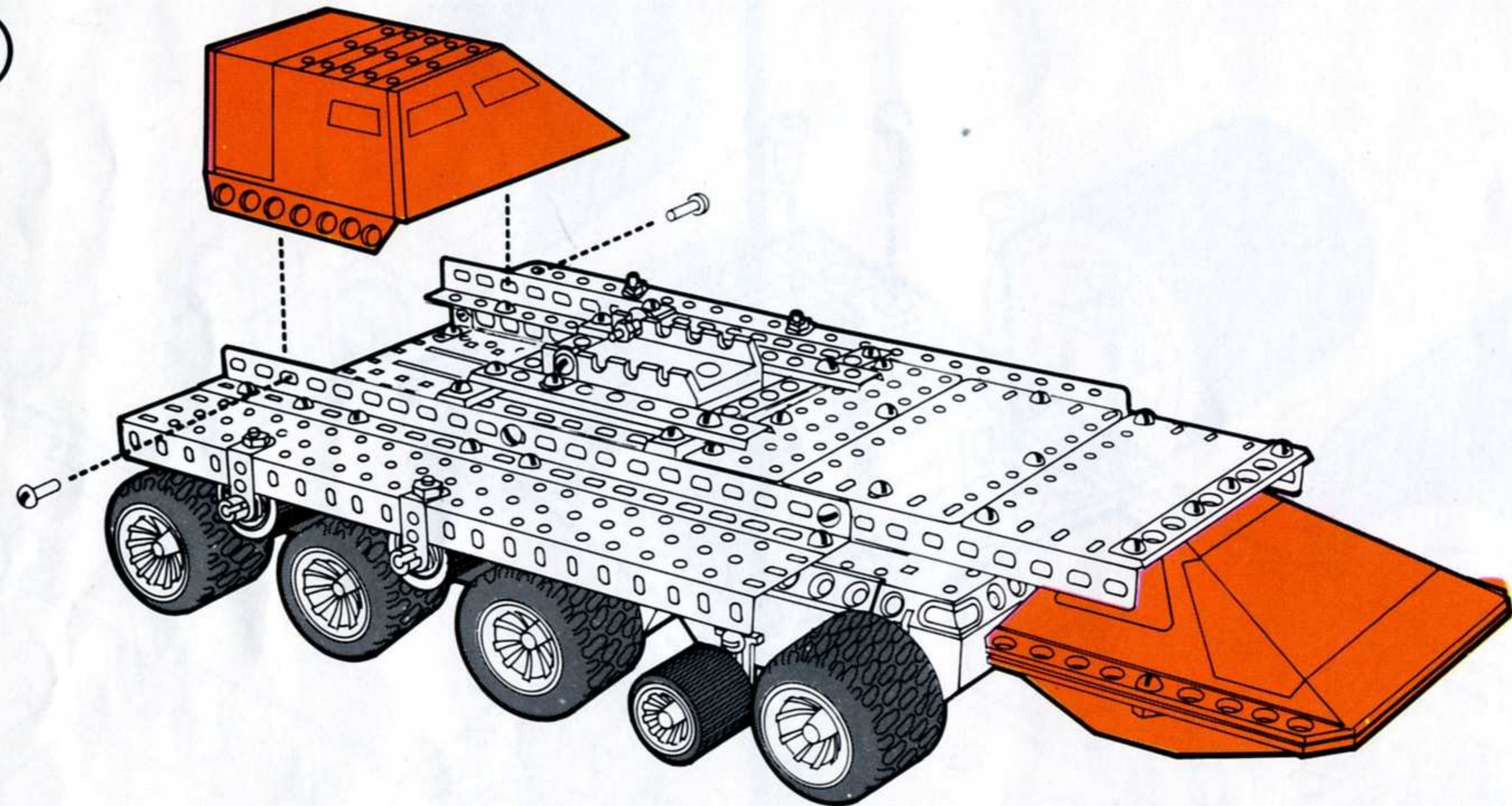

17

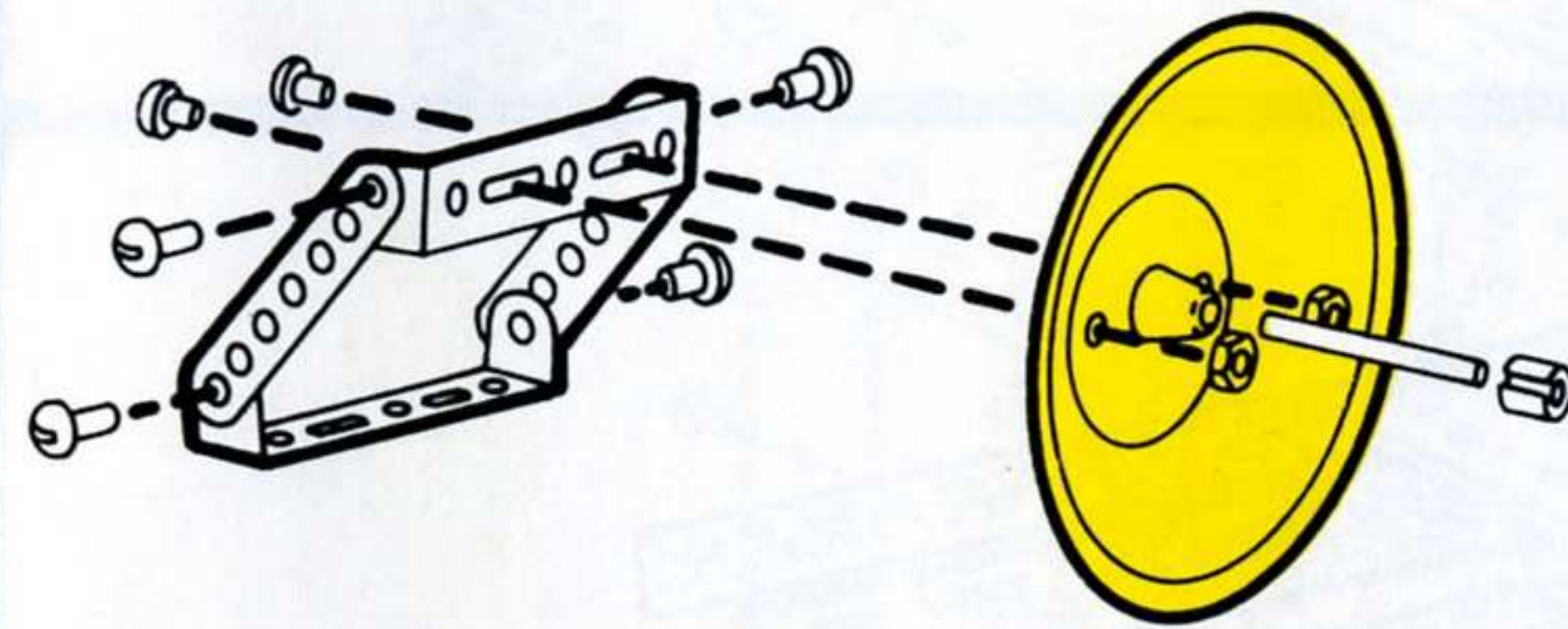

18

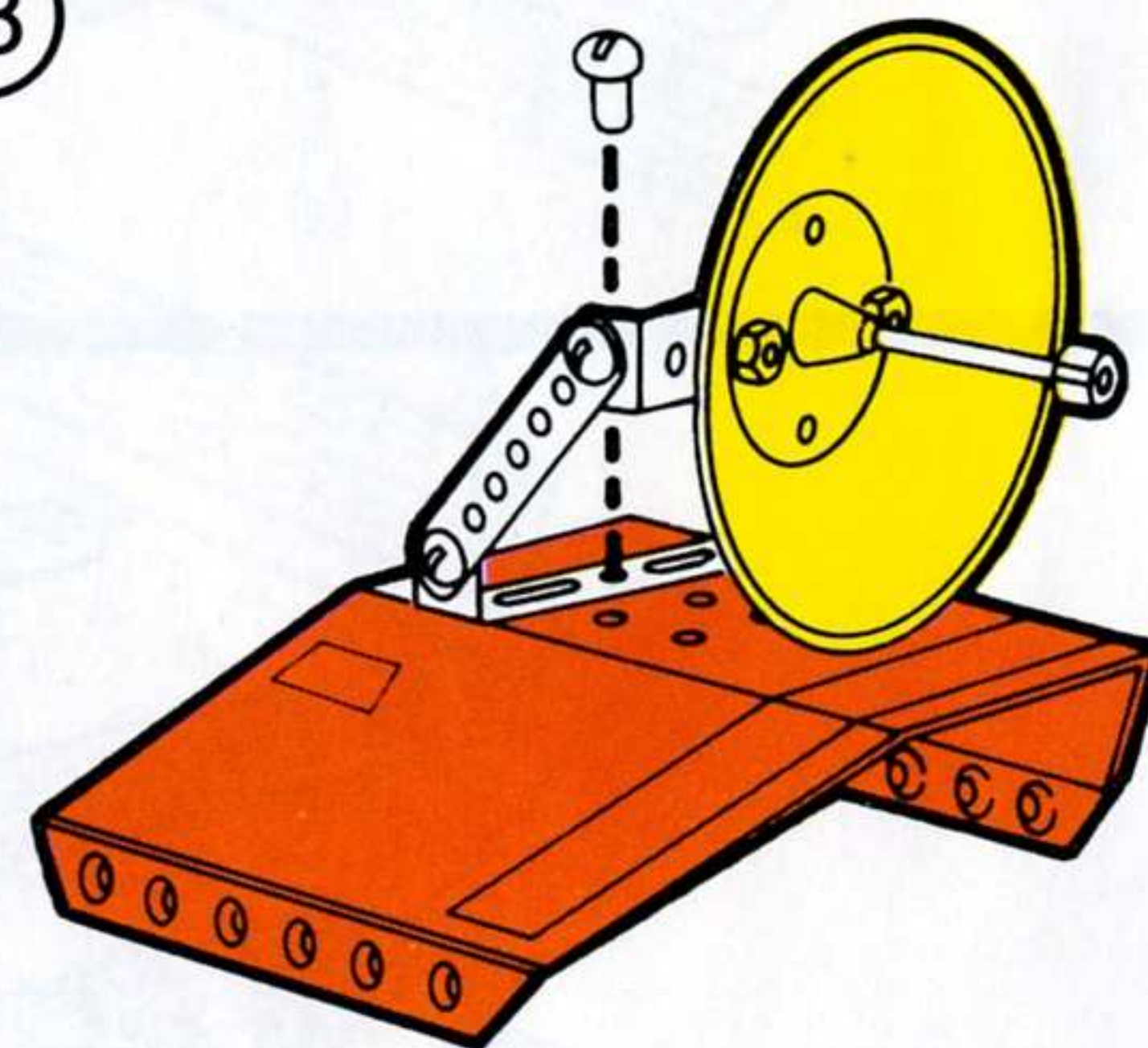

14

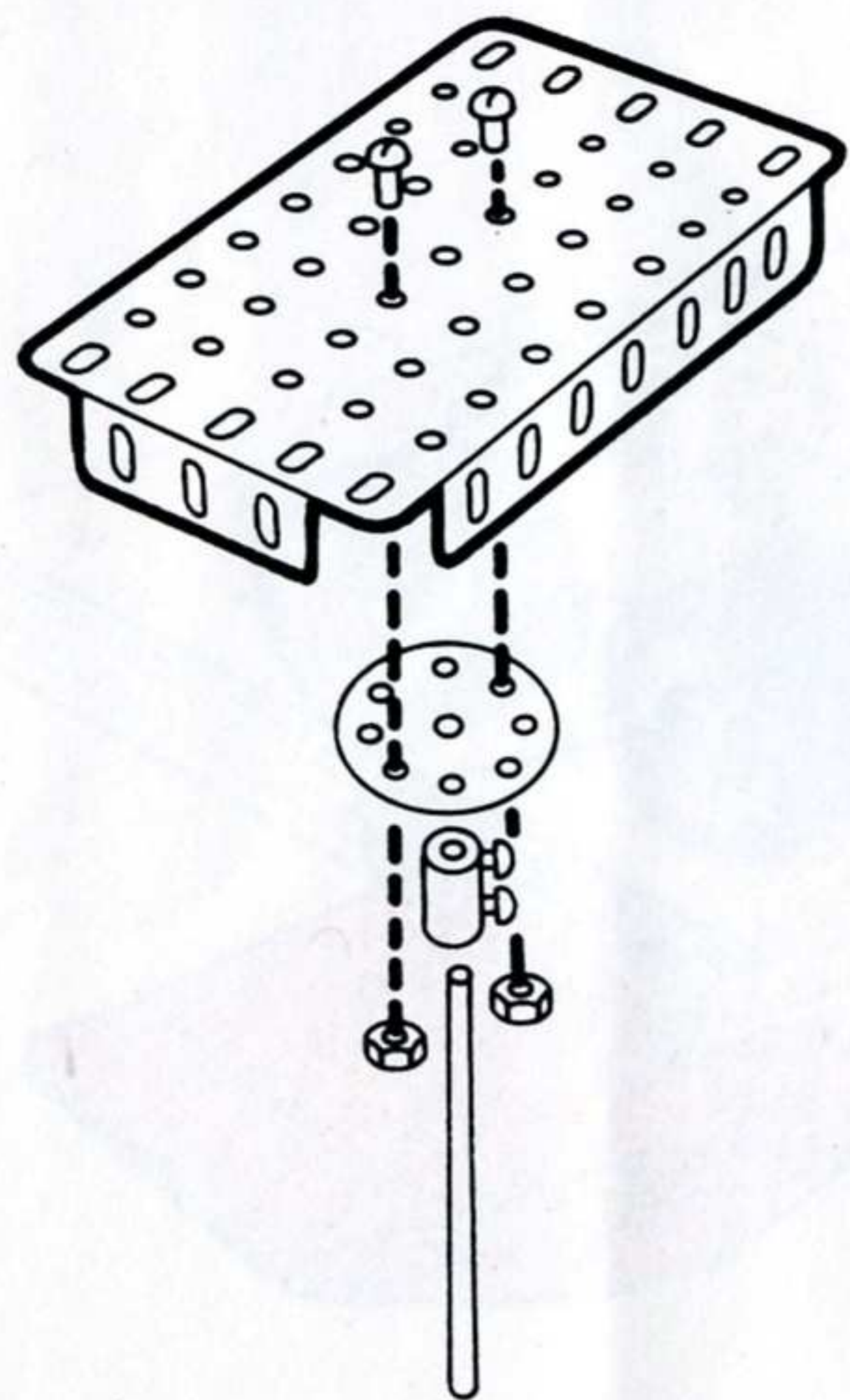

15

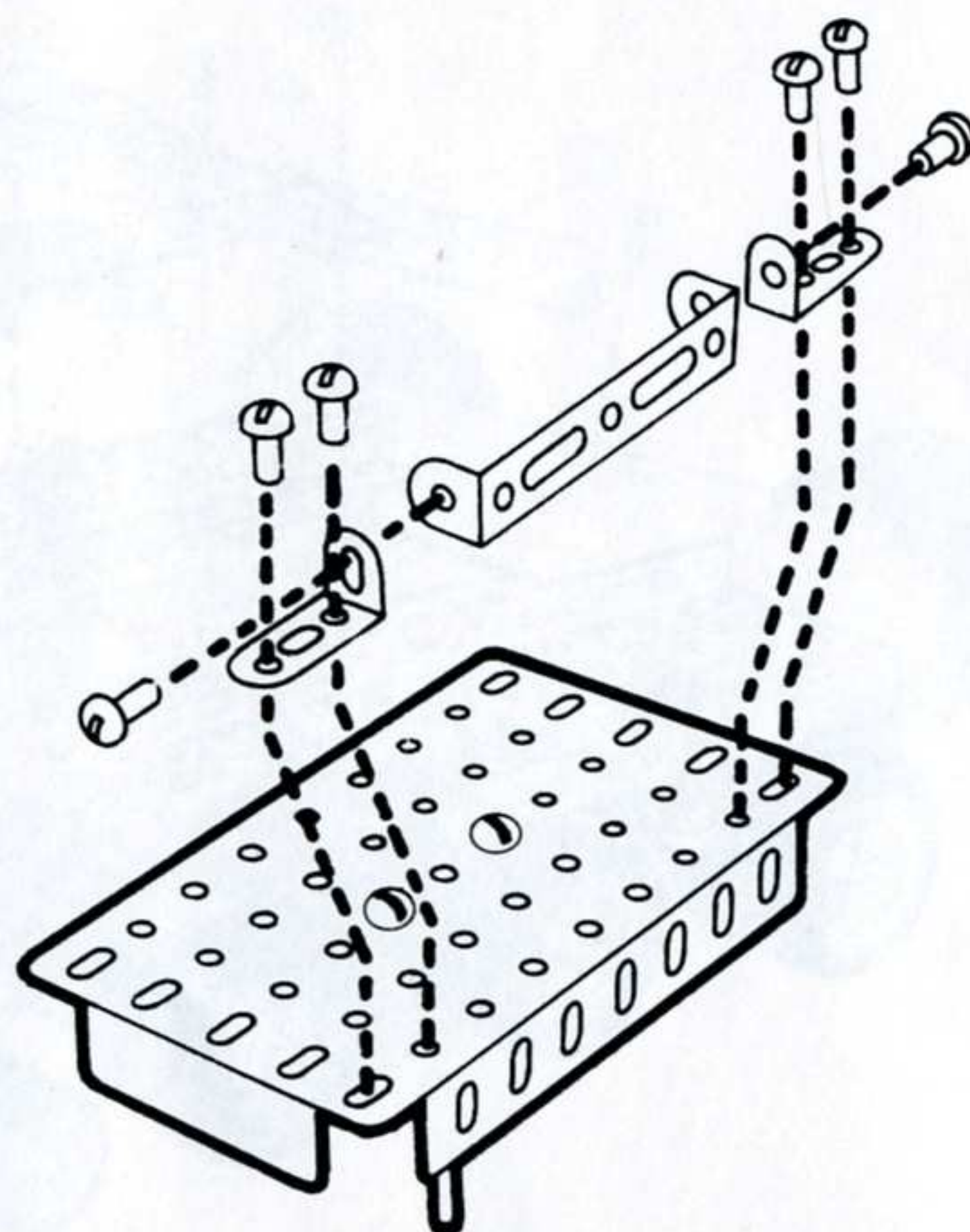

19

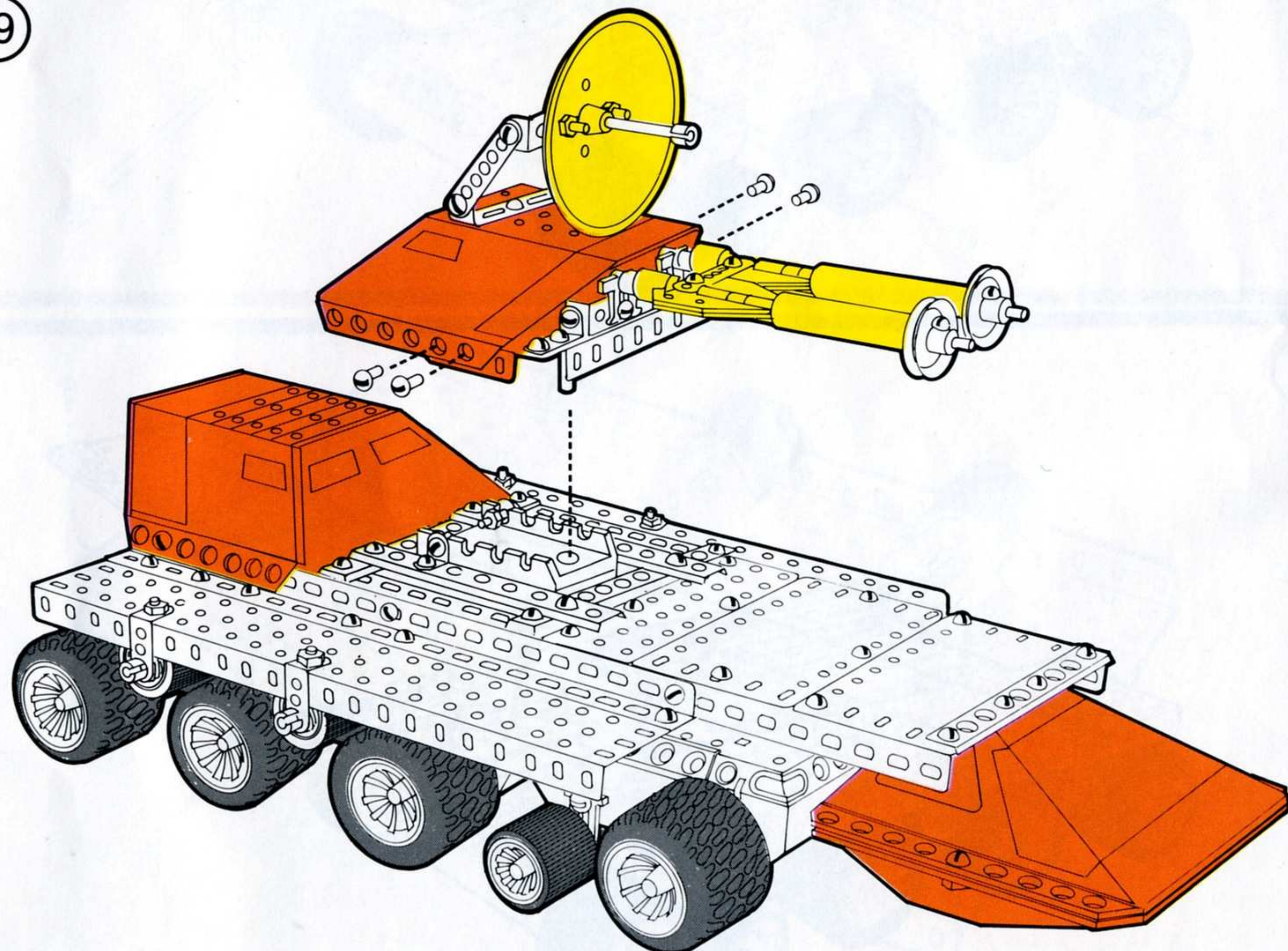



# MISSION COMMAND VEHICLE

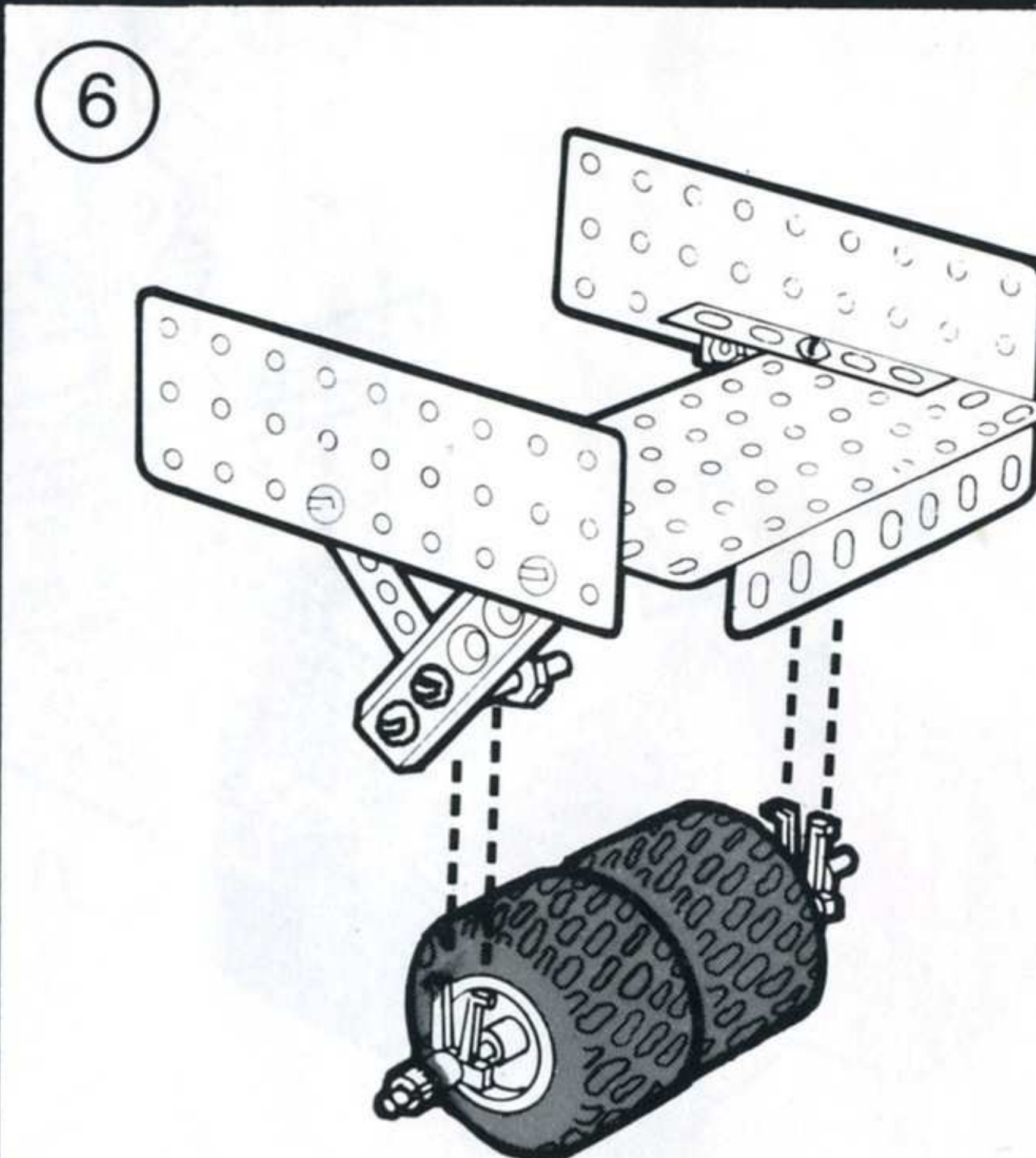
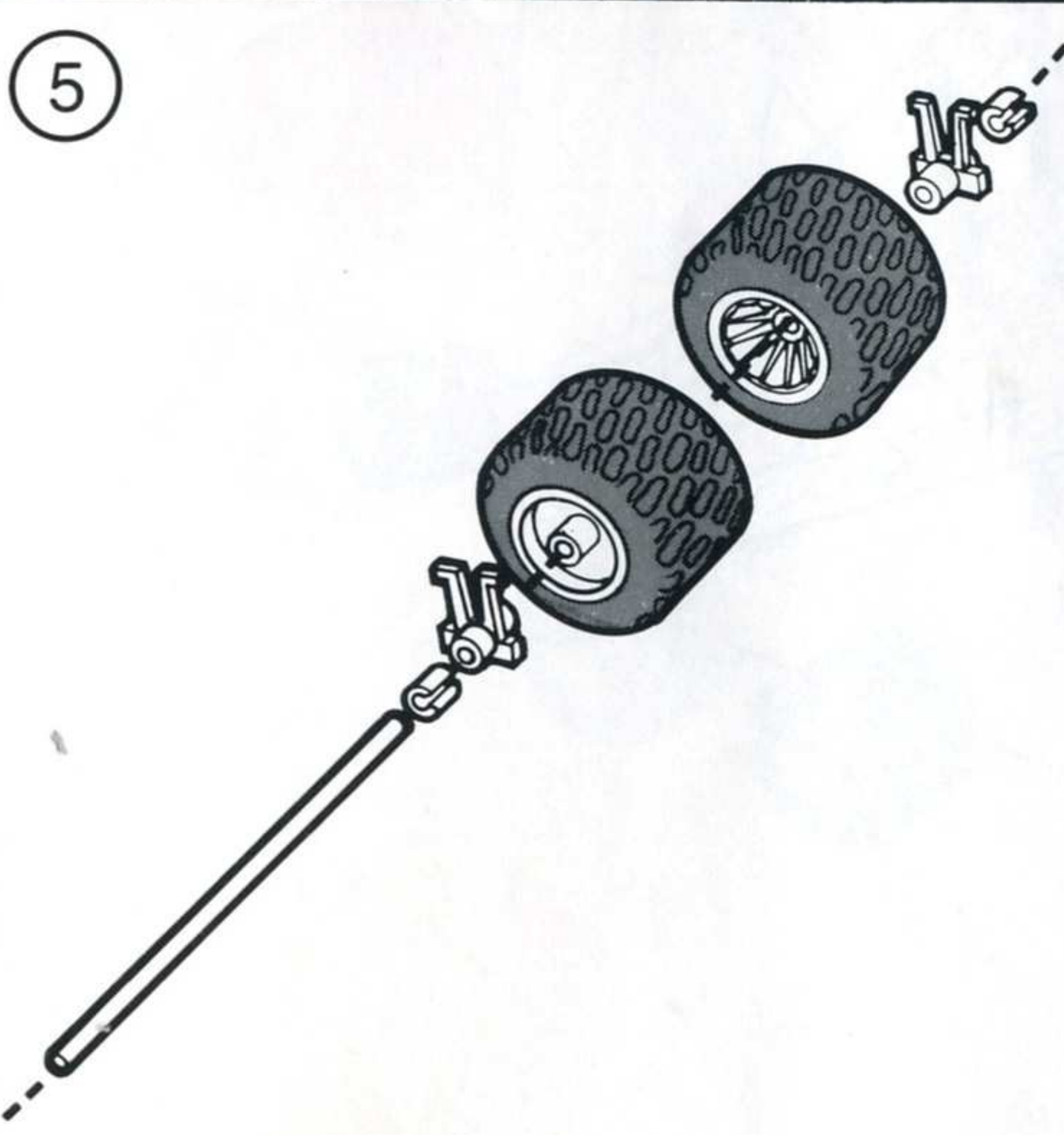
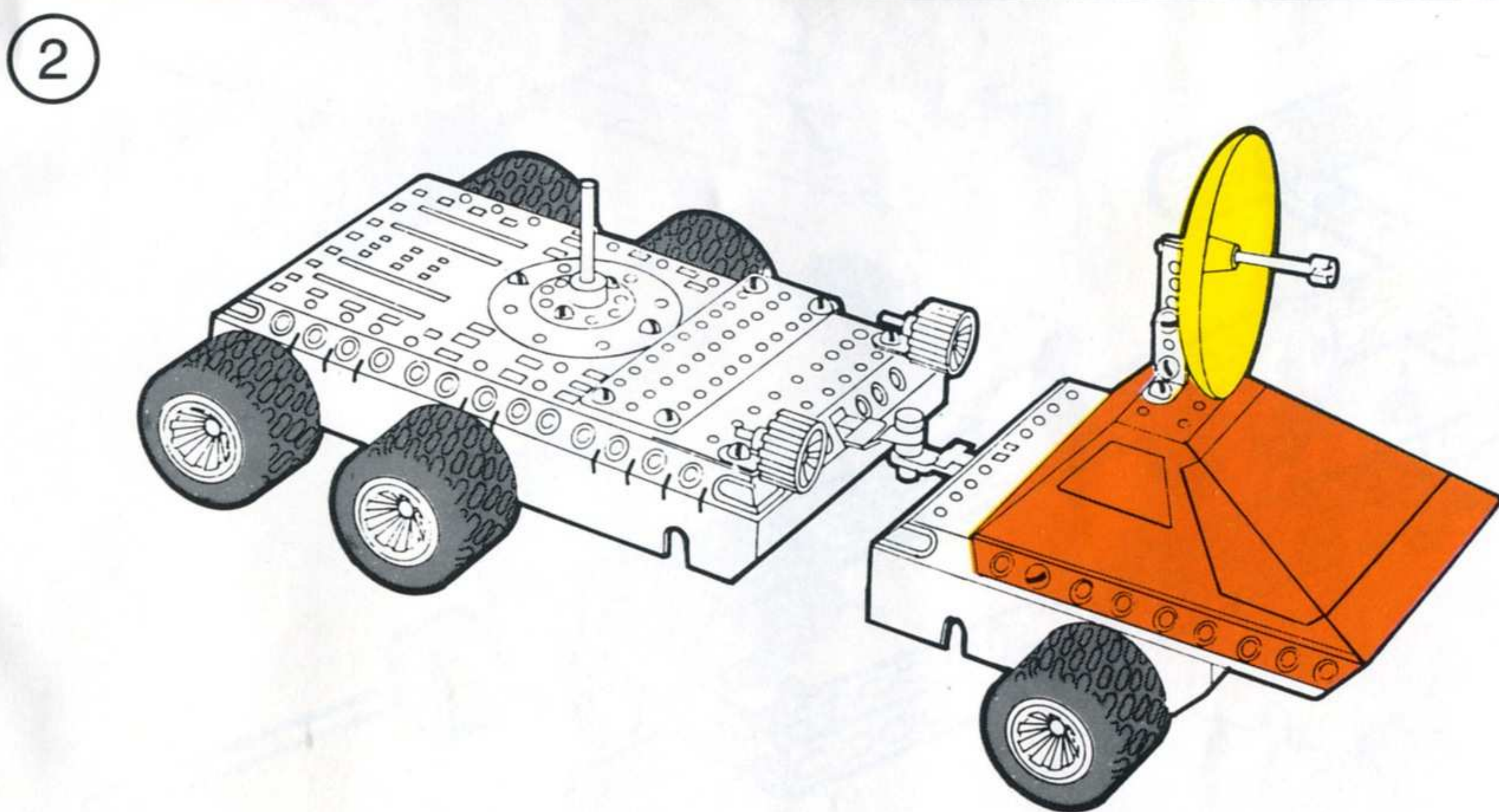
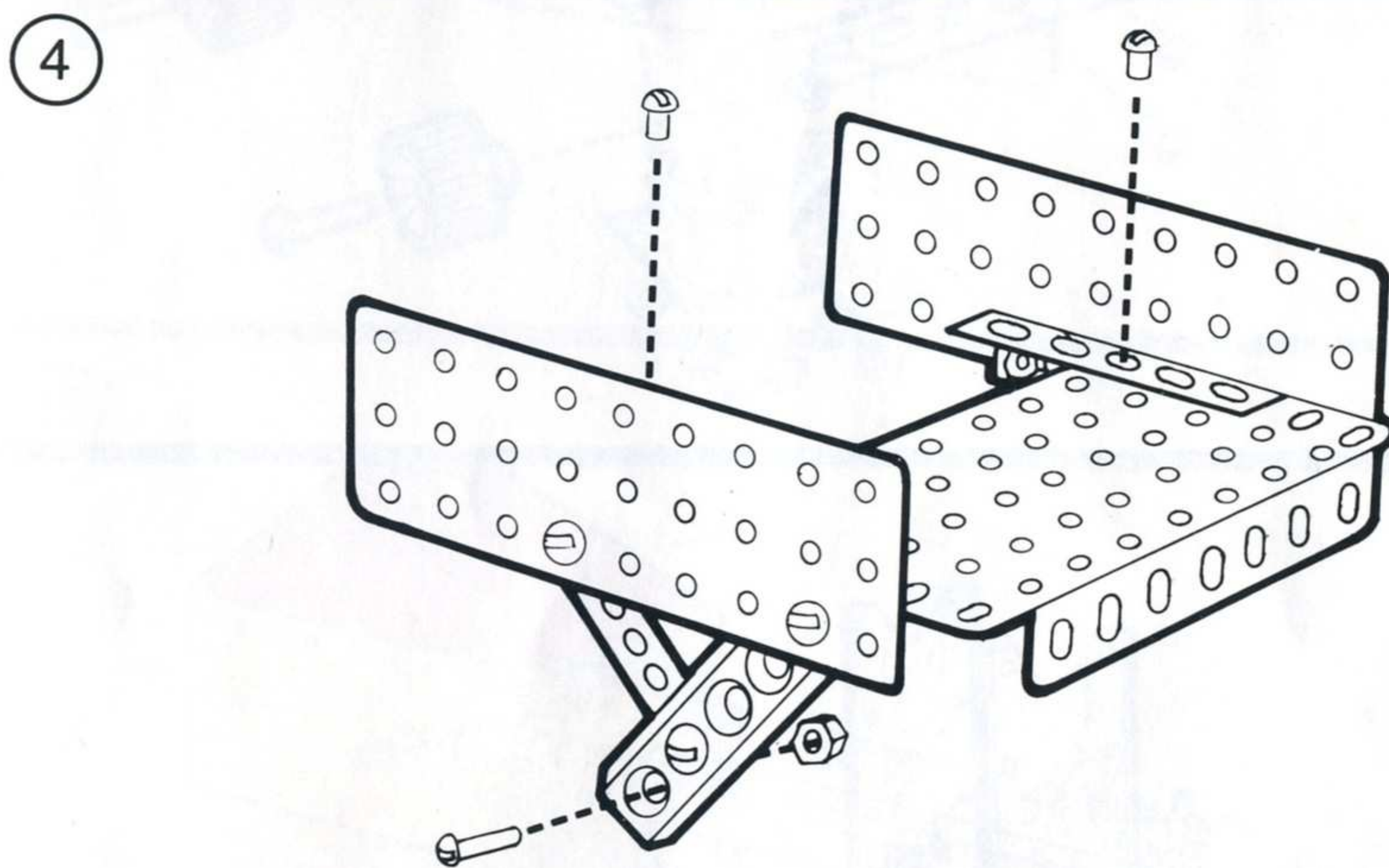
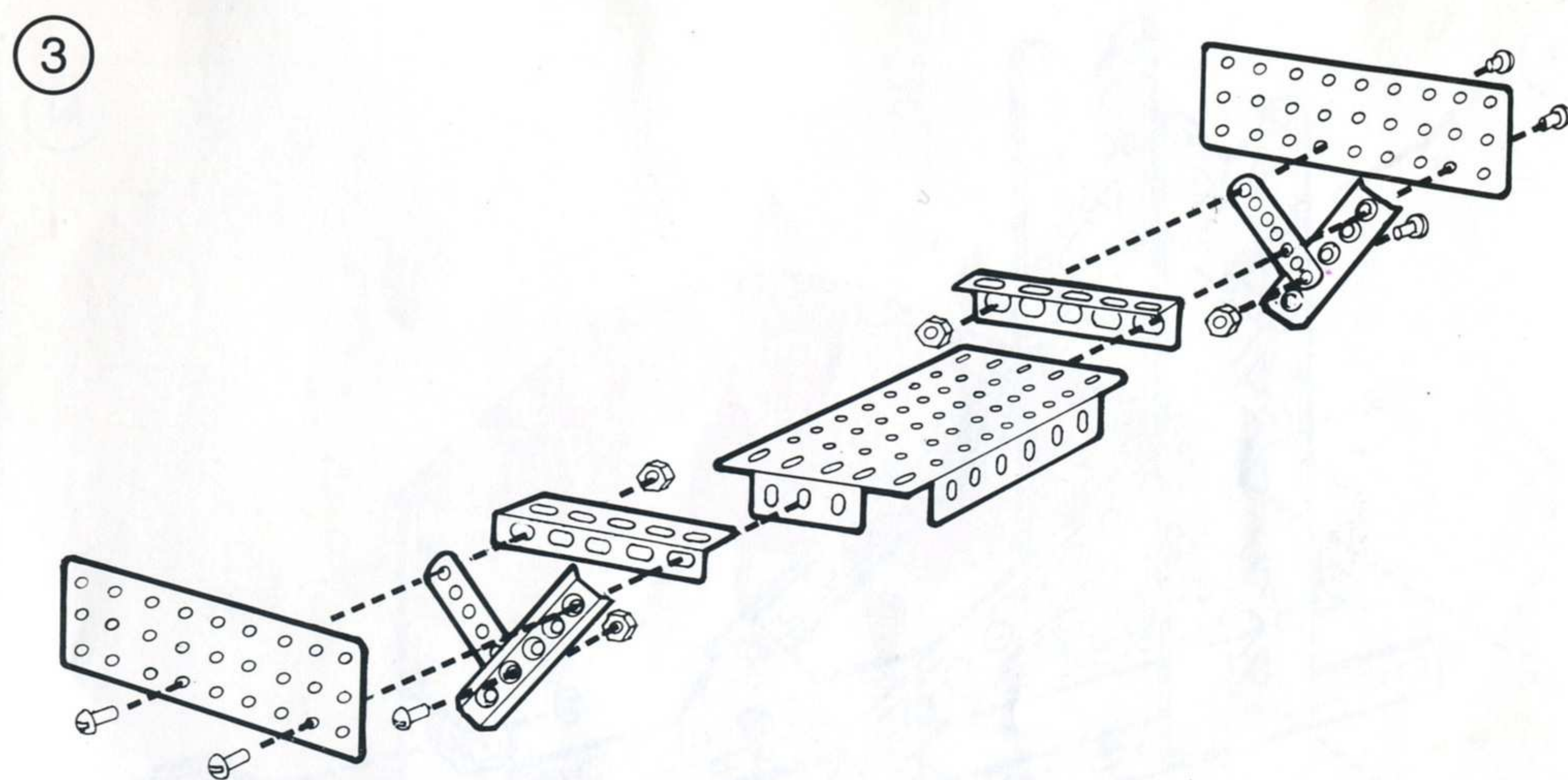
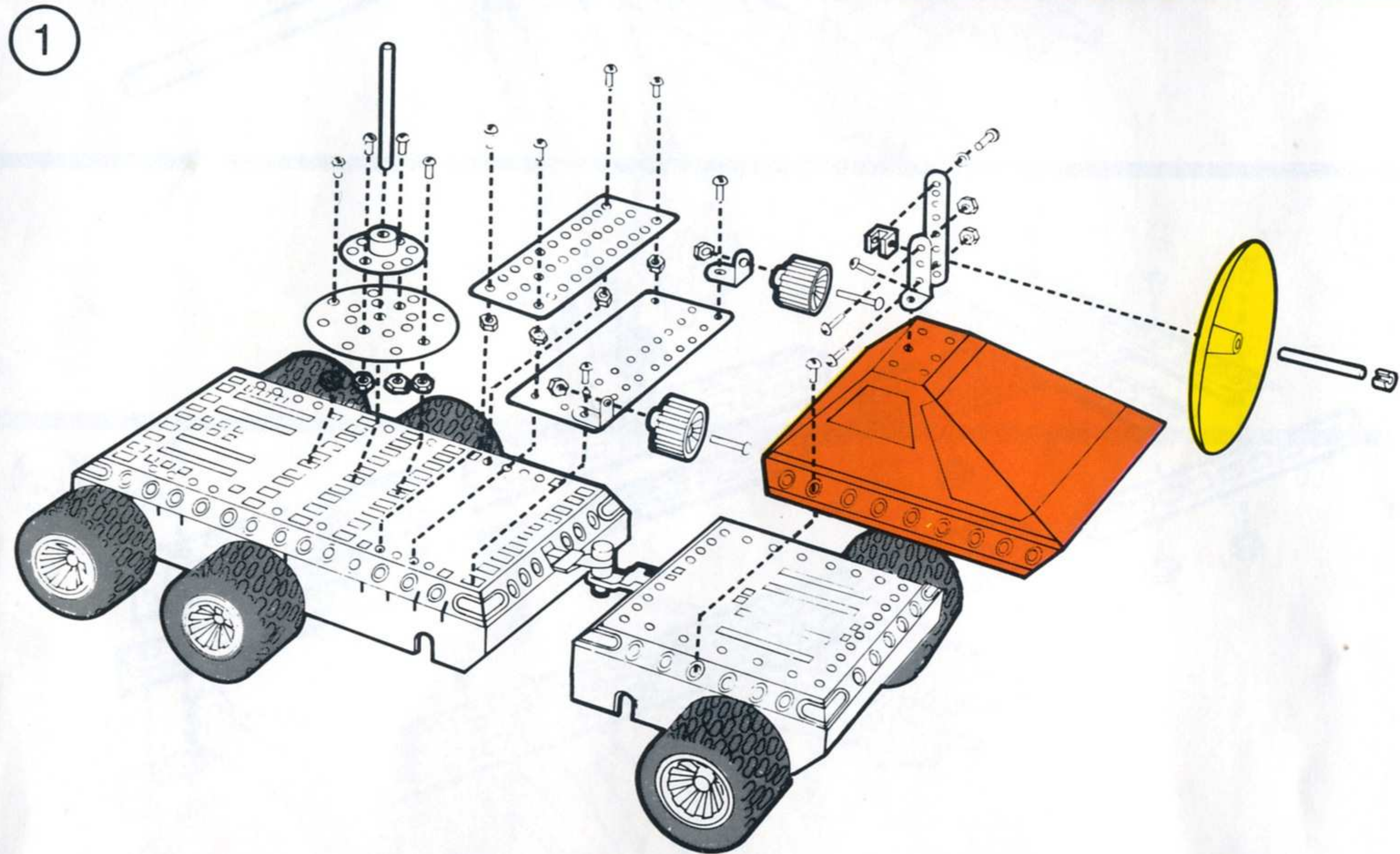



7

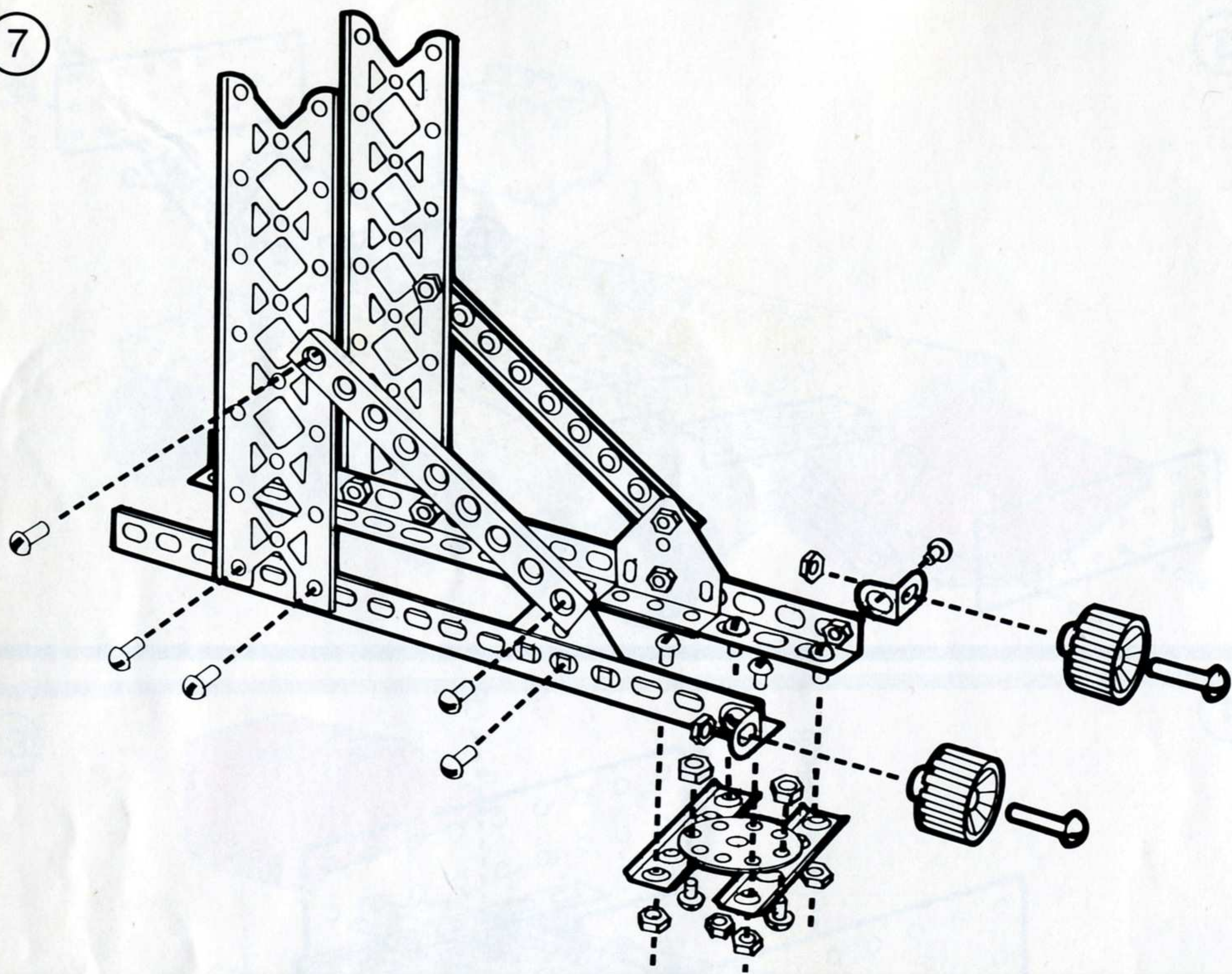

9

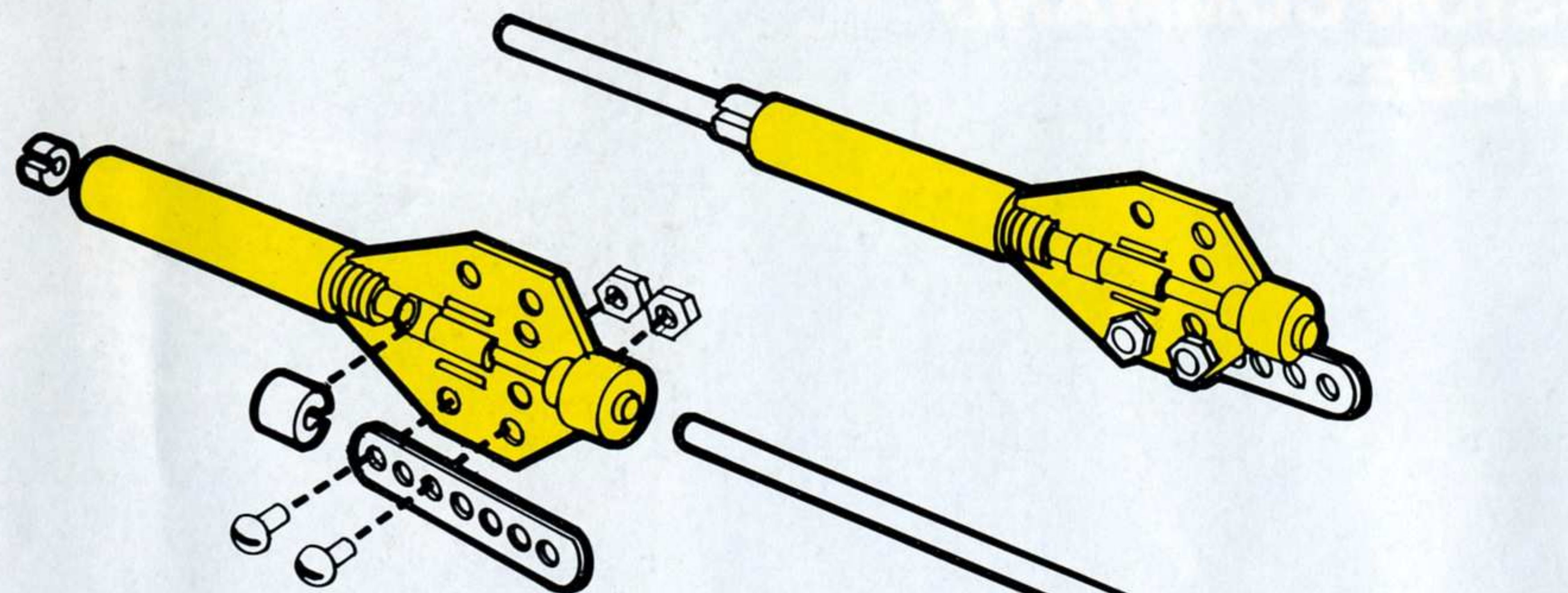

8

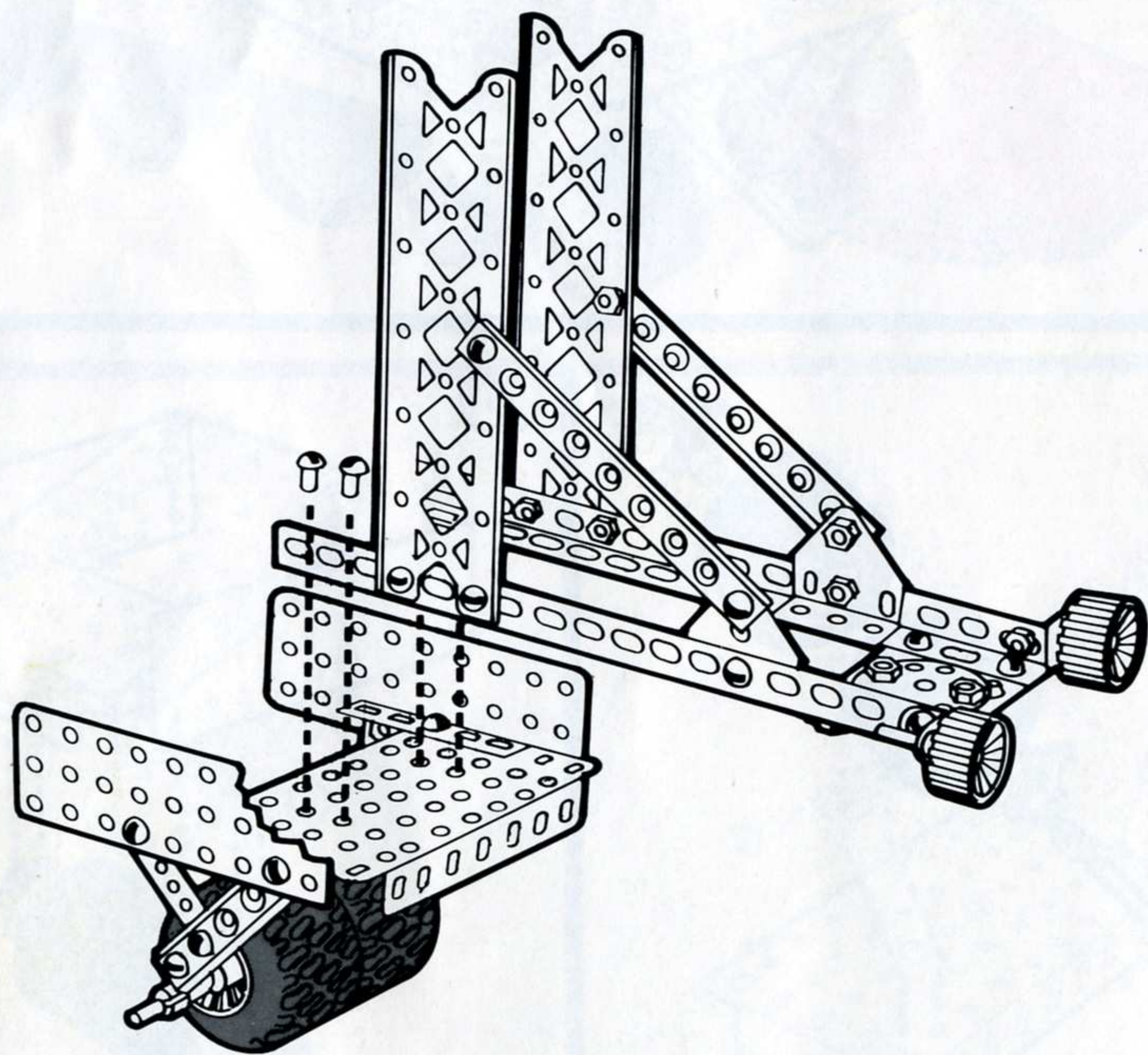

10

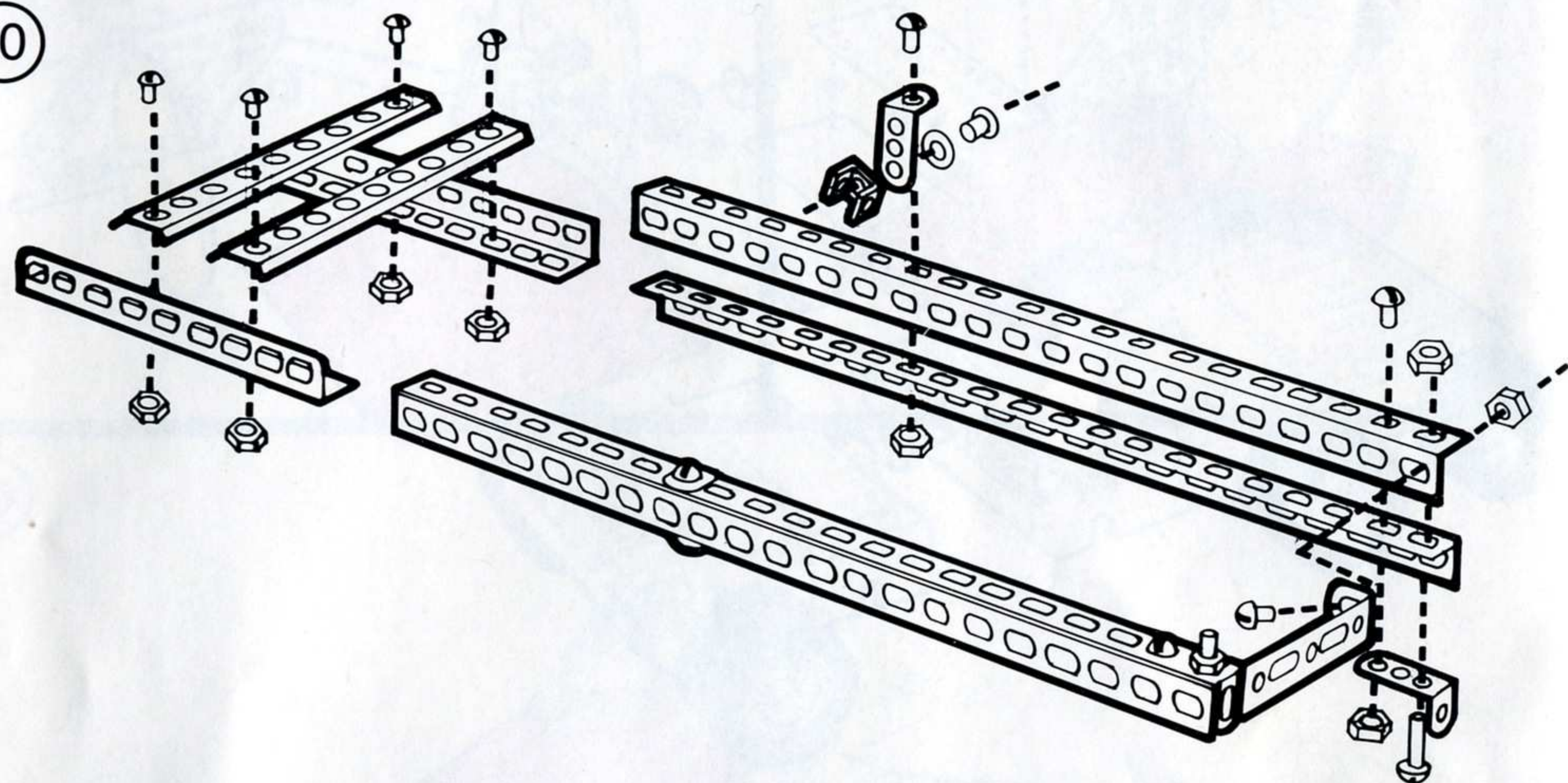

11

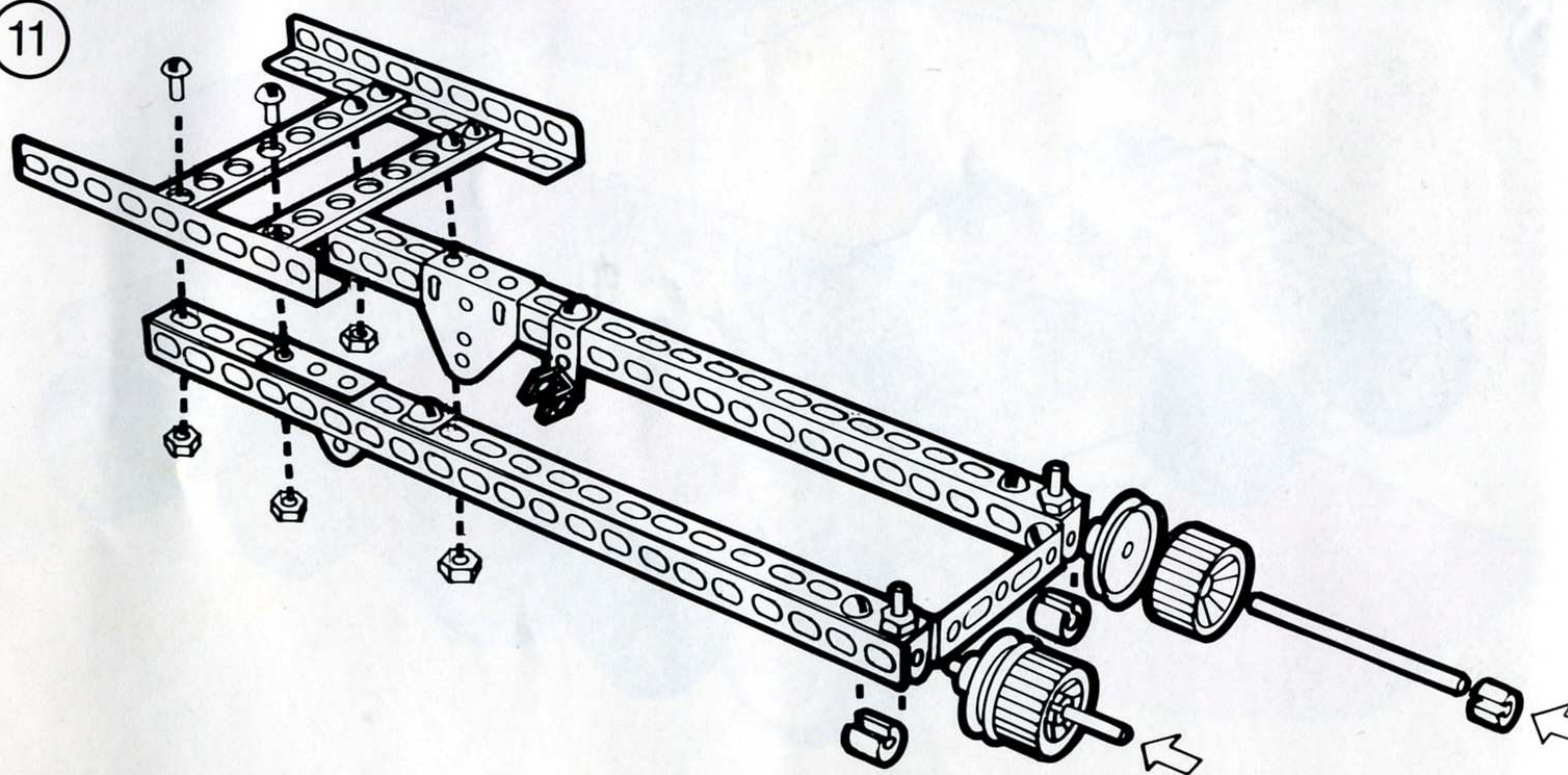



12

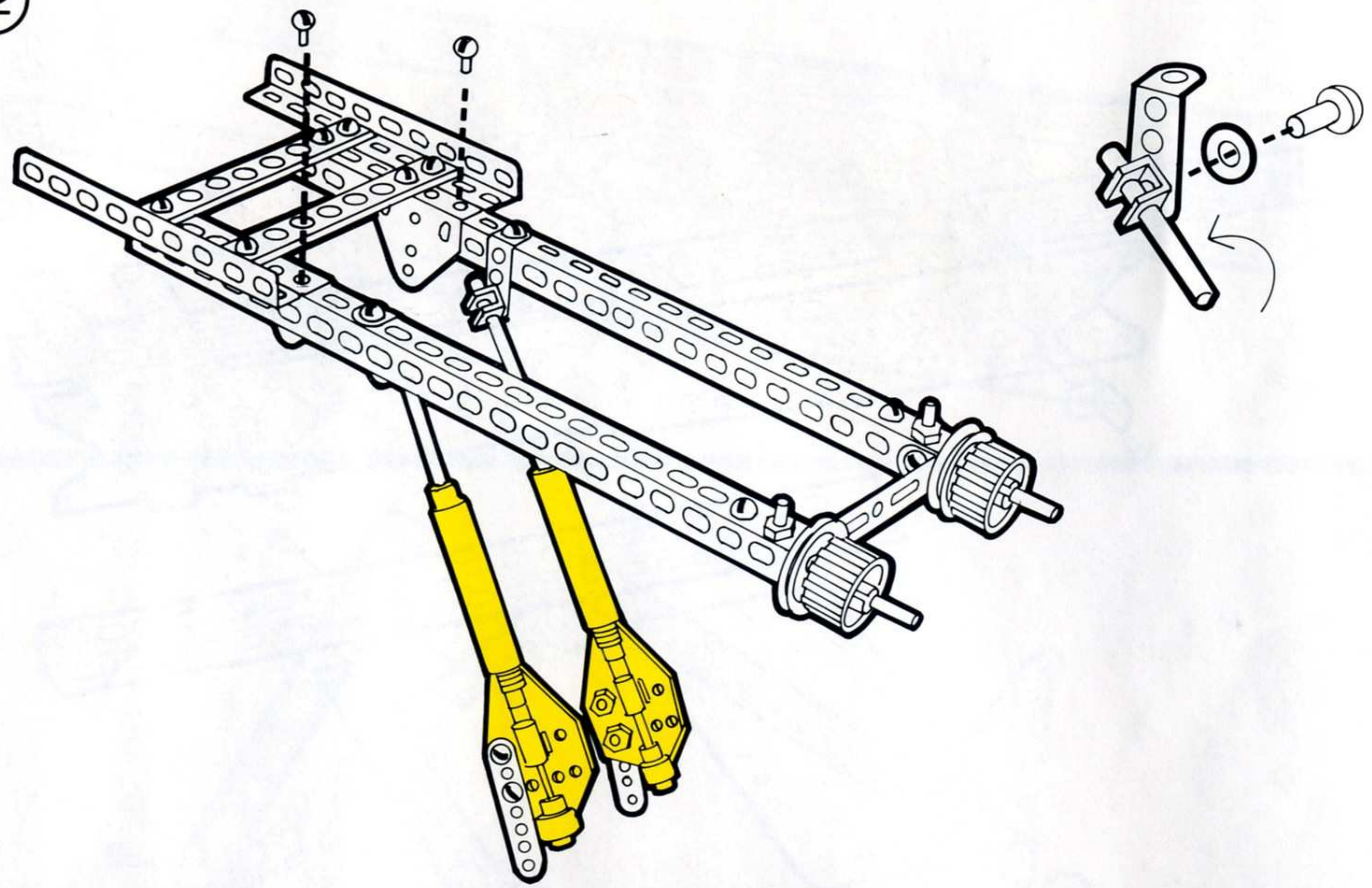

14

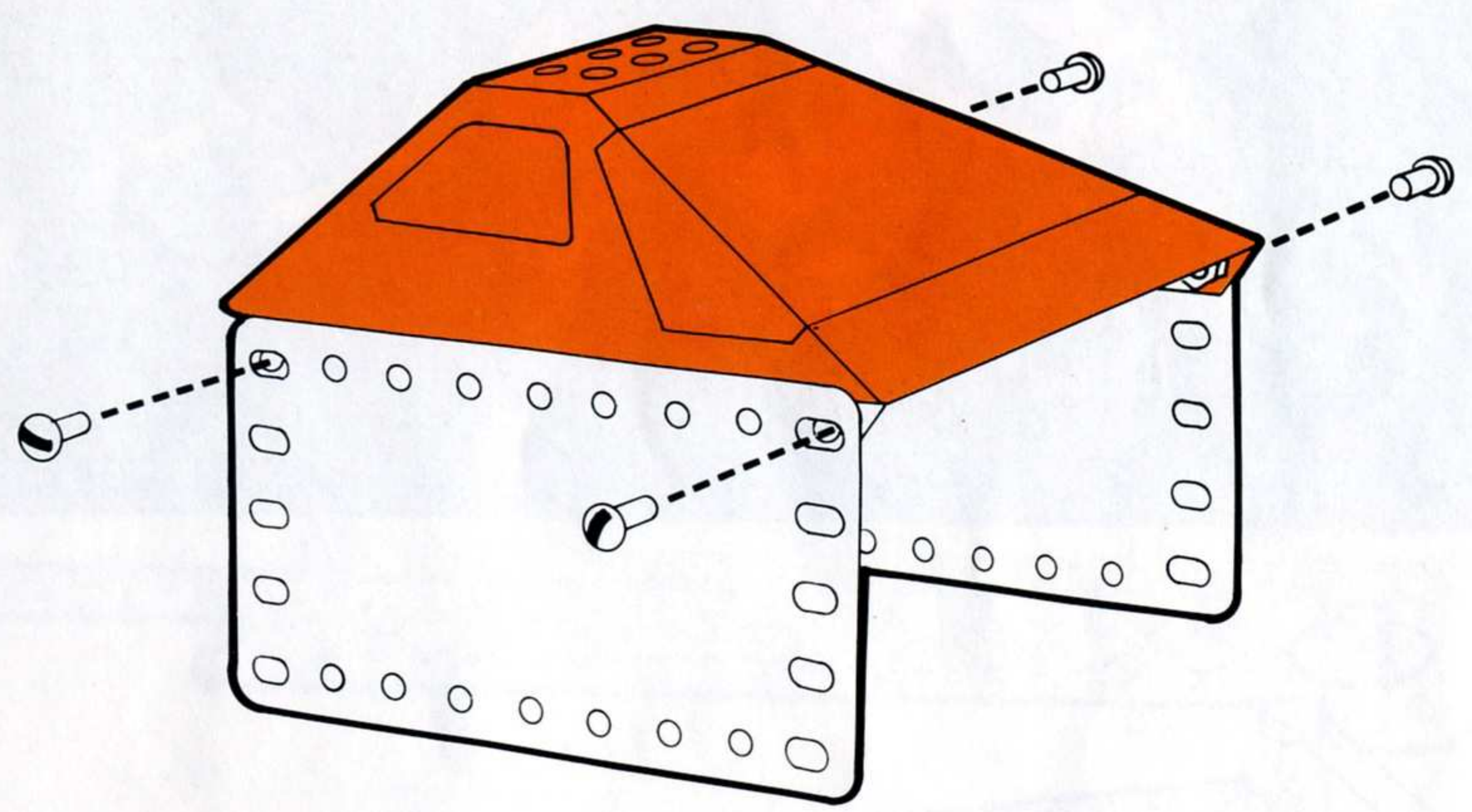

13

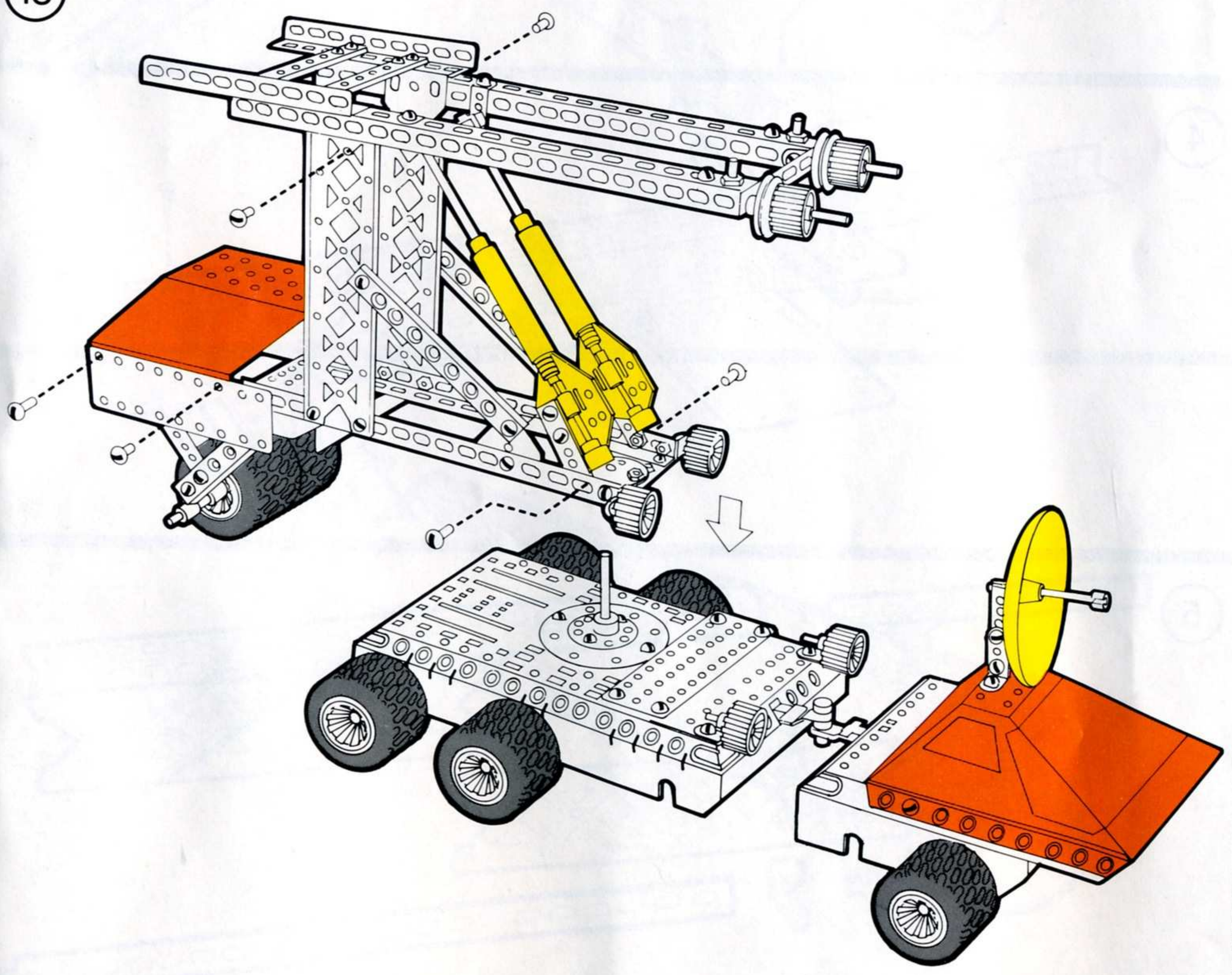

15

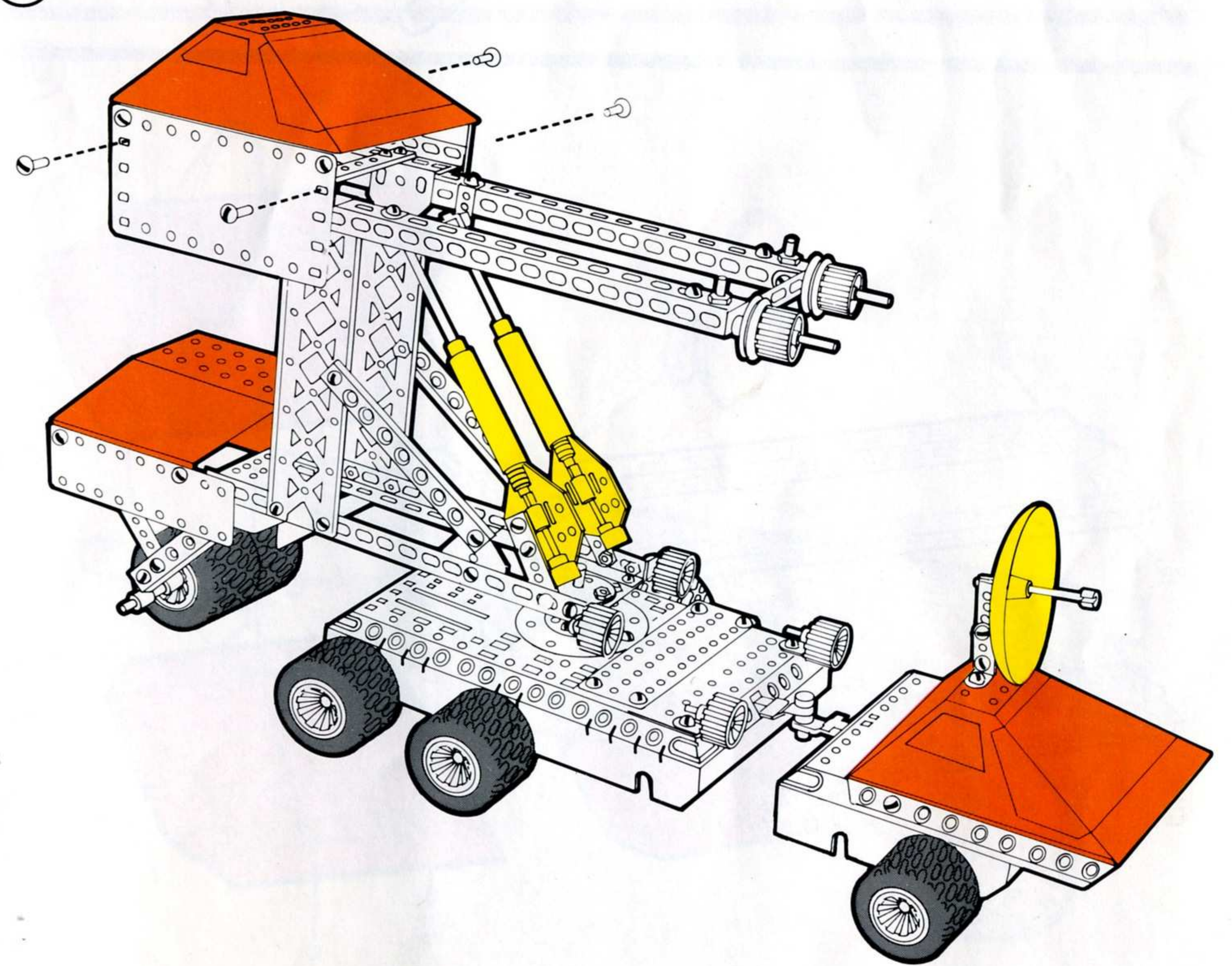



# STAR CRUISER

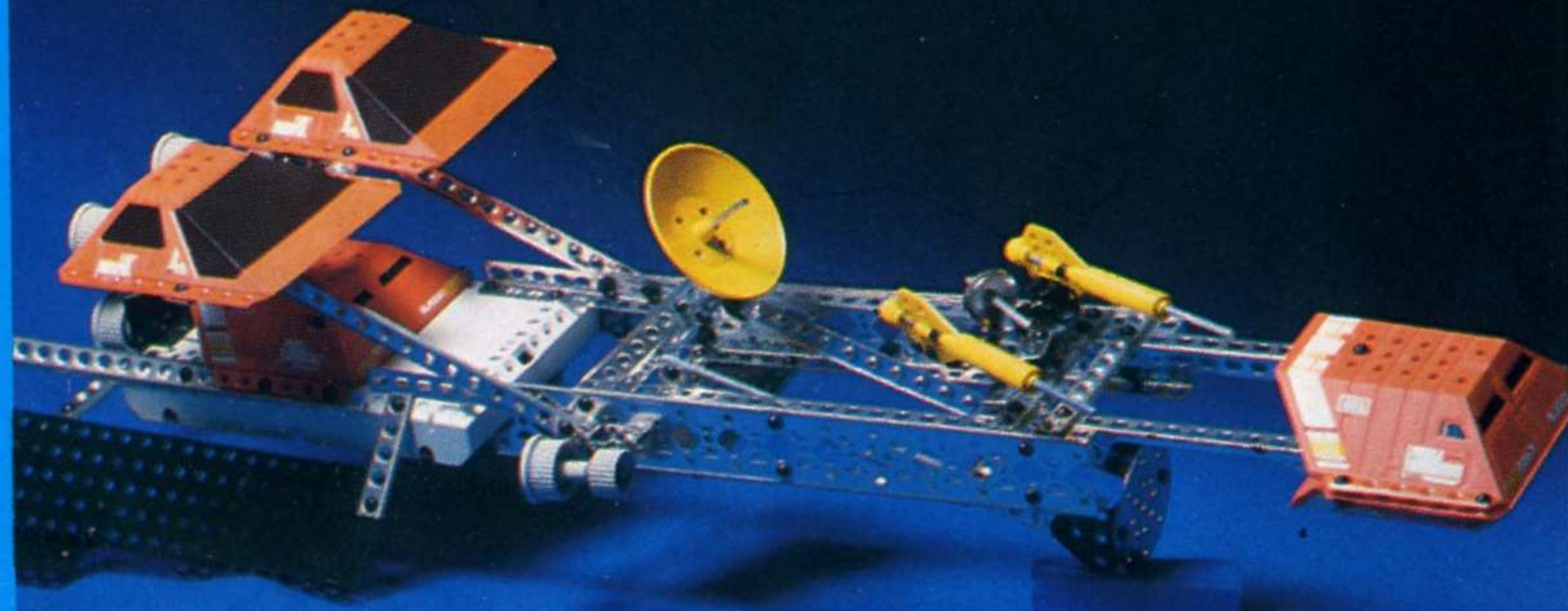

1

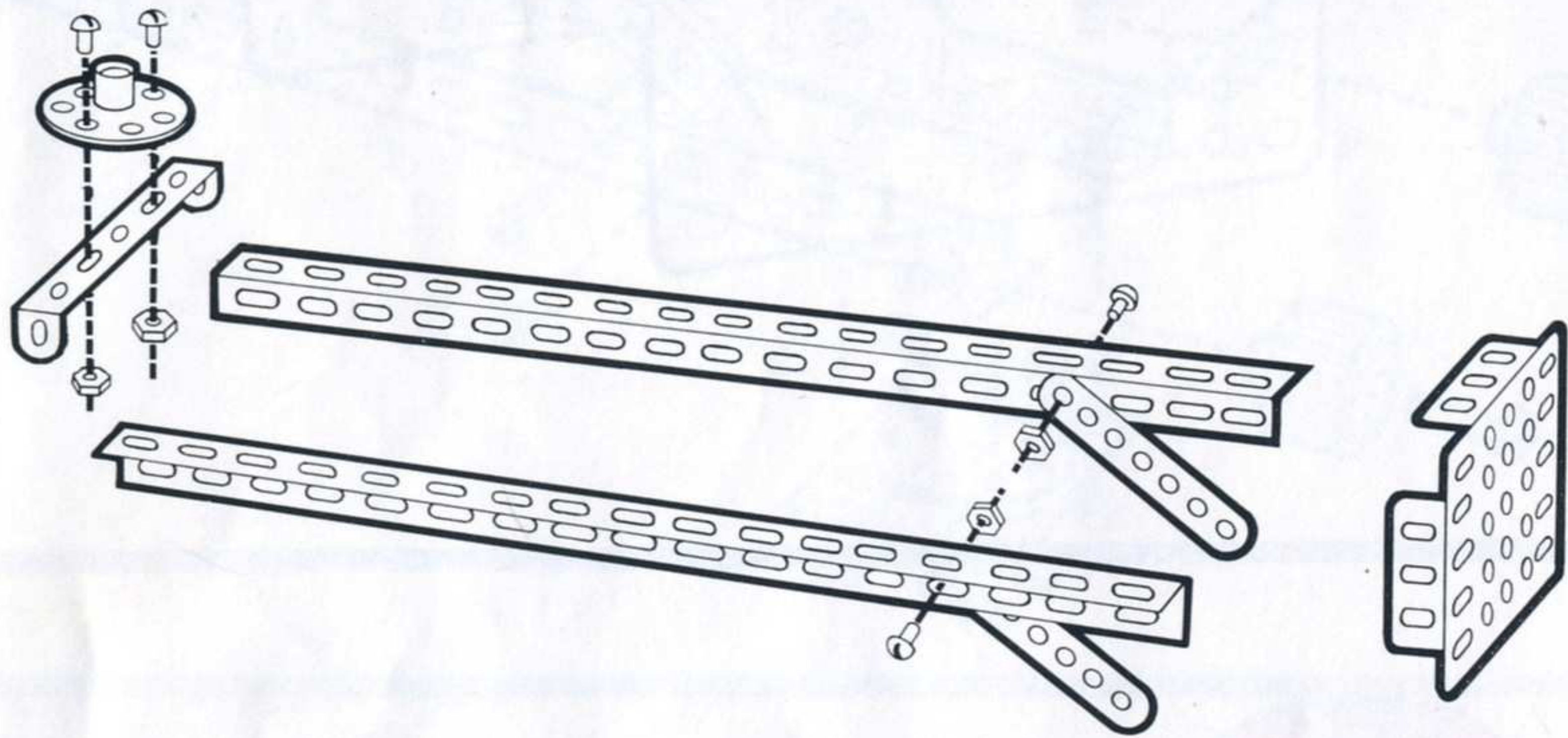

2

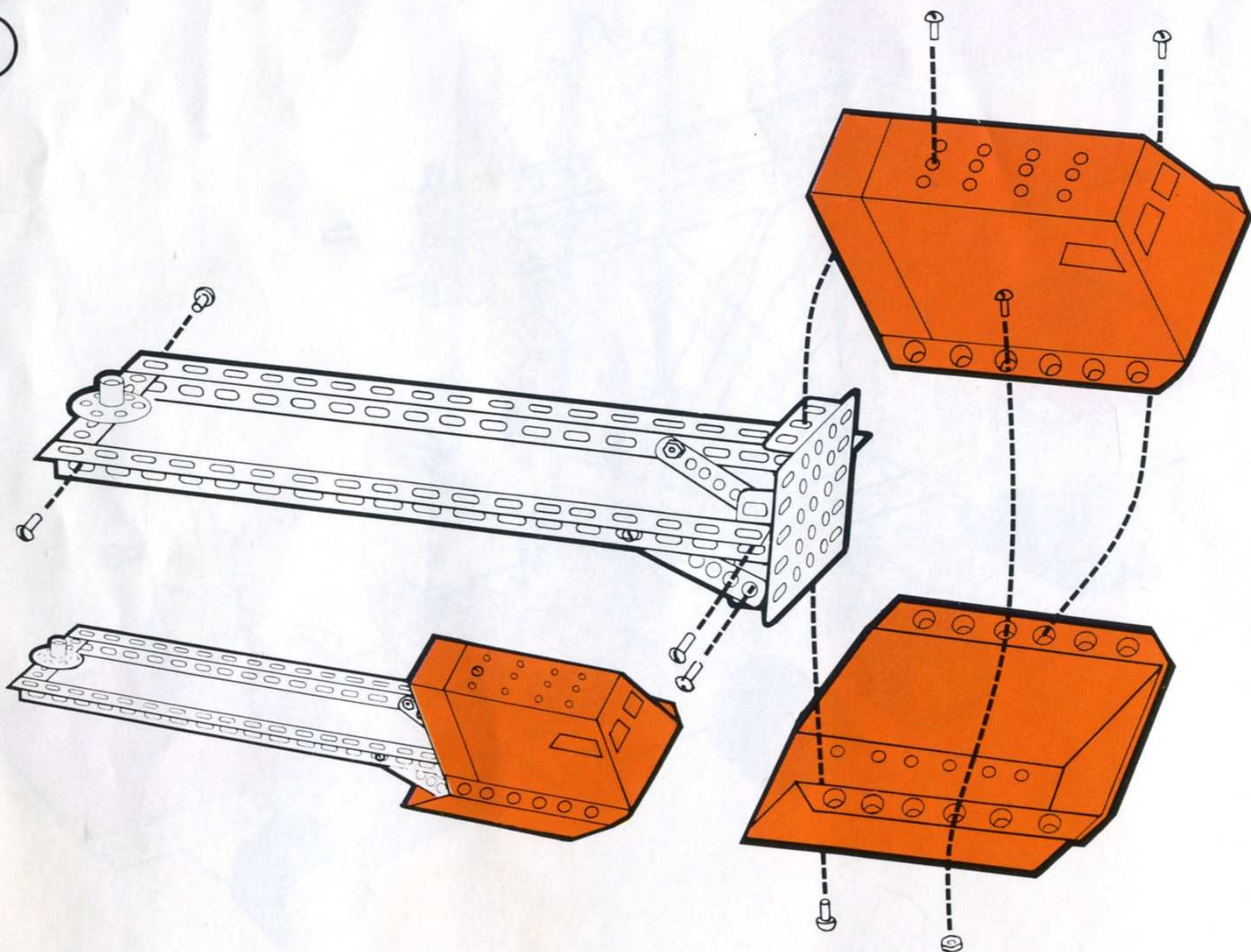

3

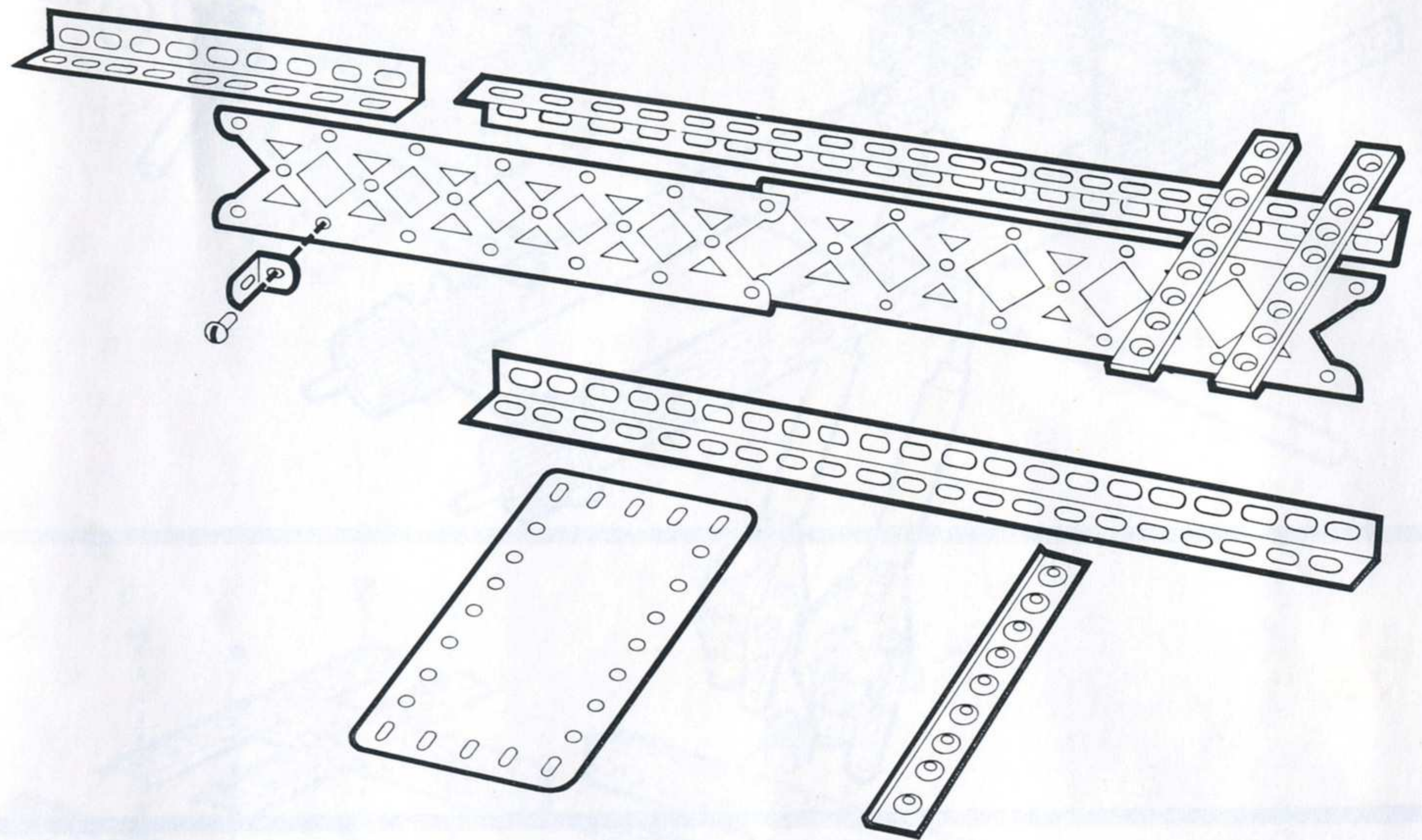

4

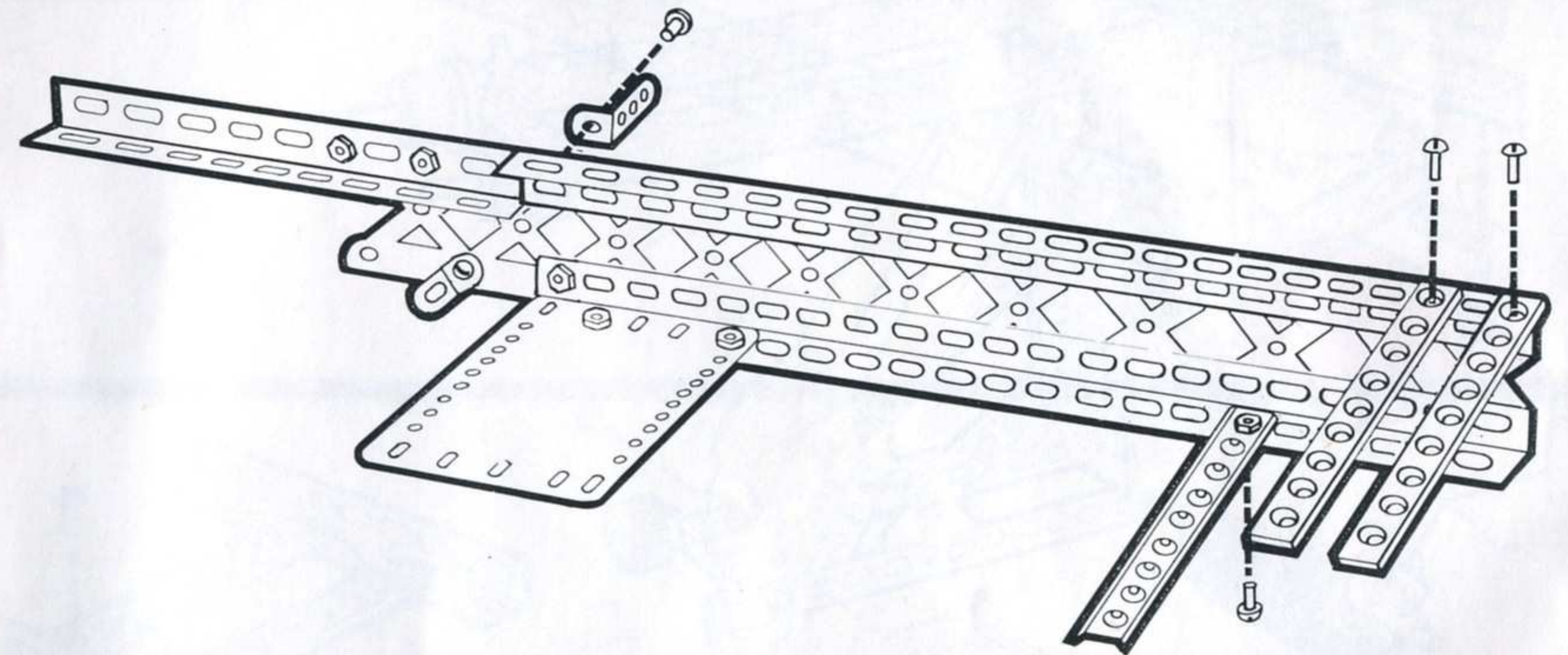

5

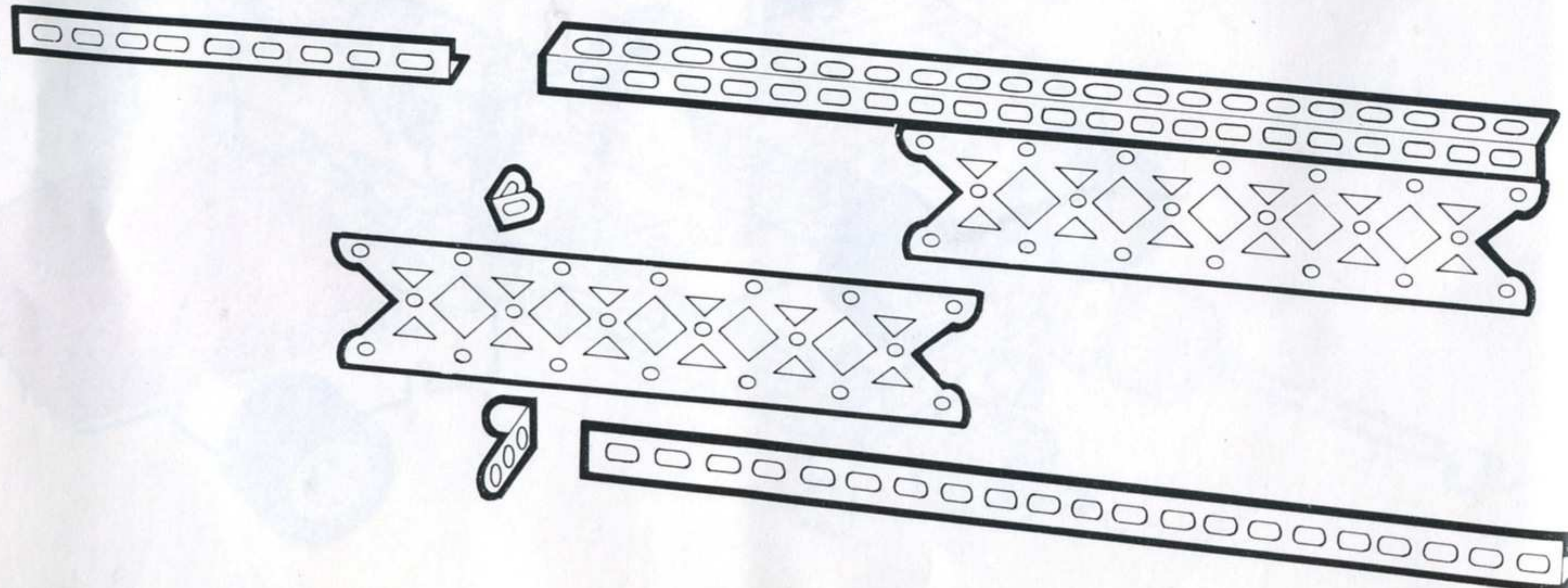



6

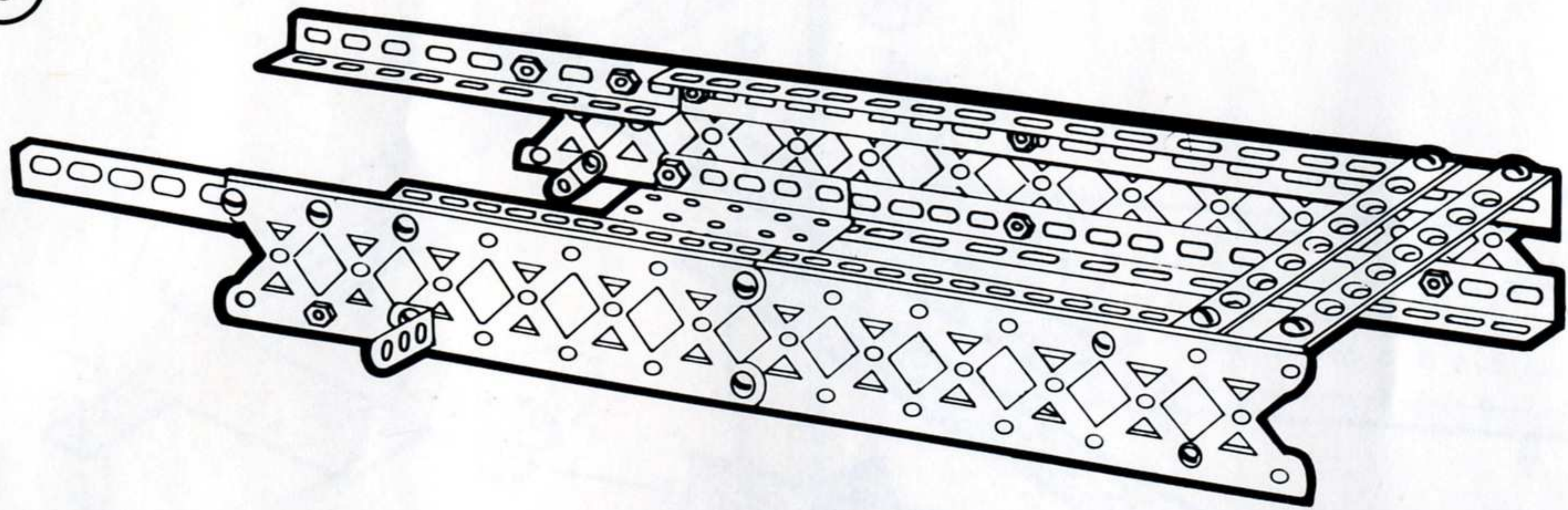

7

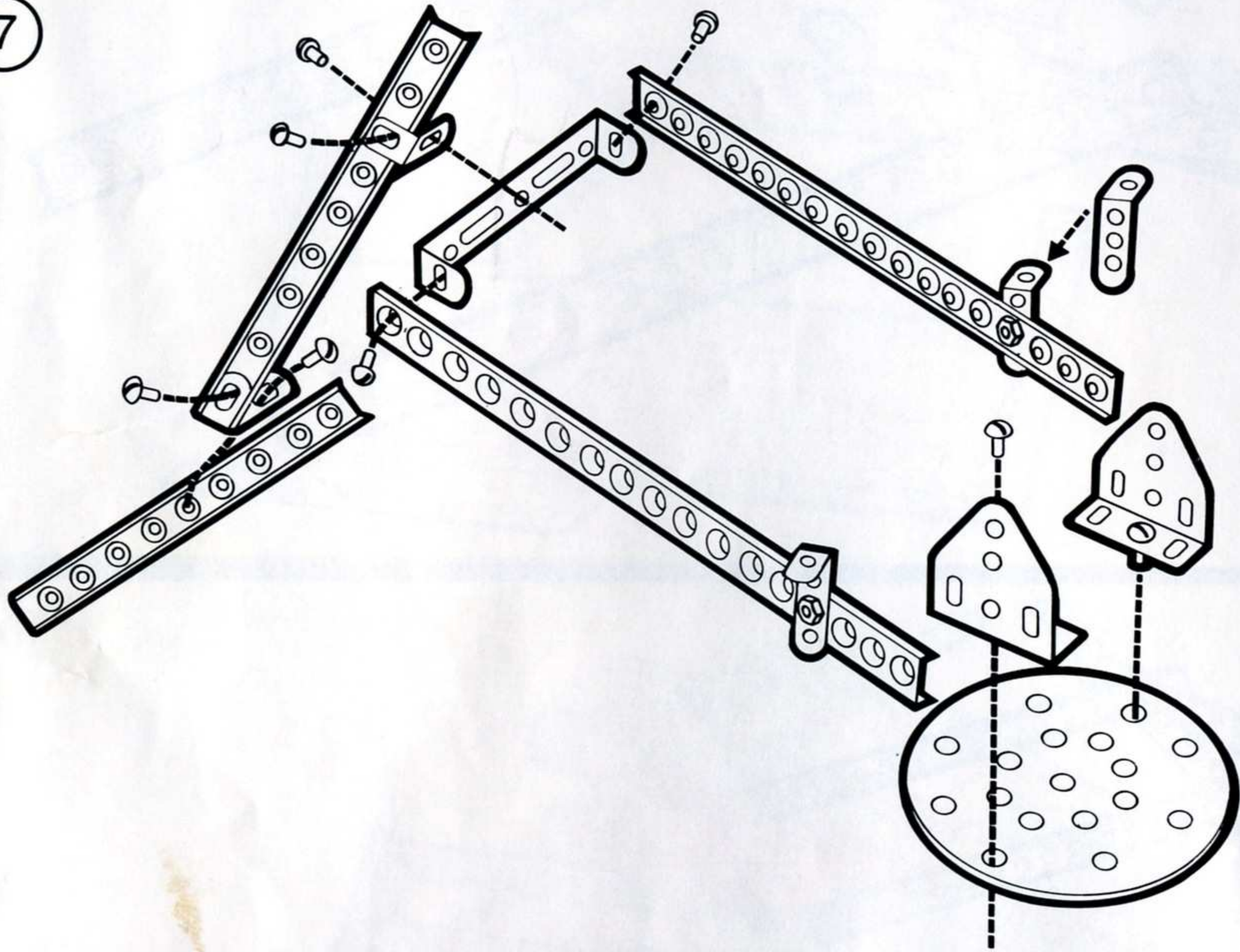

8

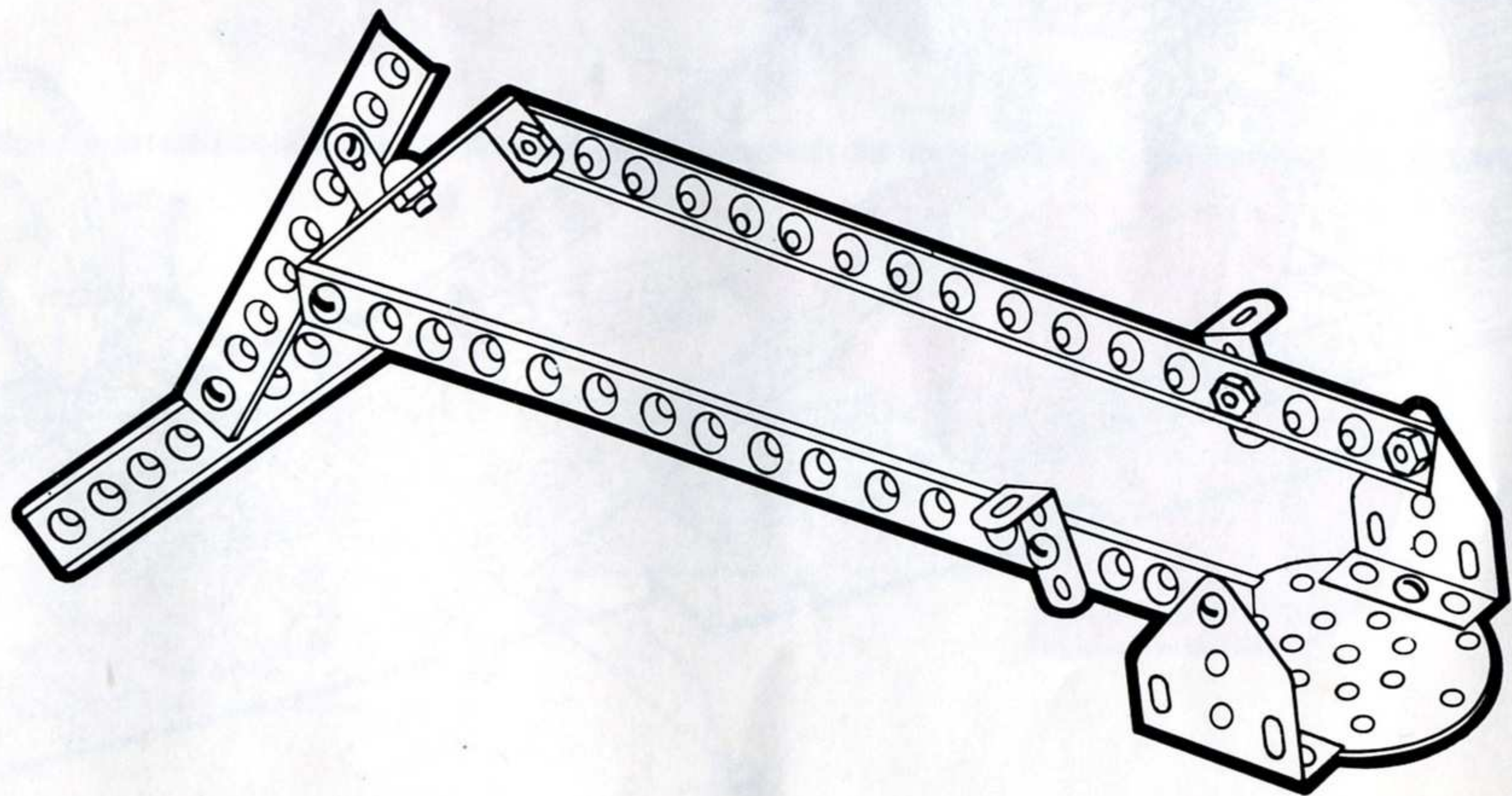

9

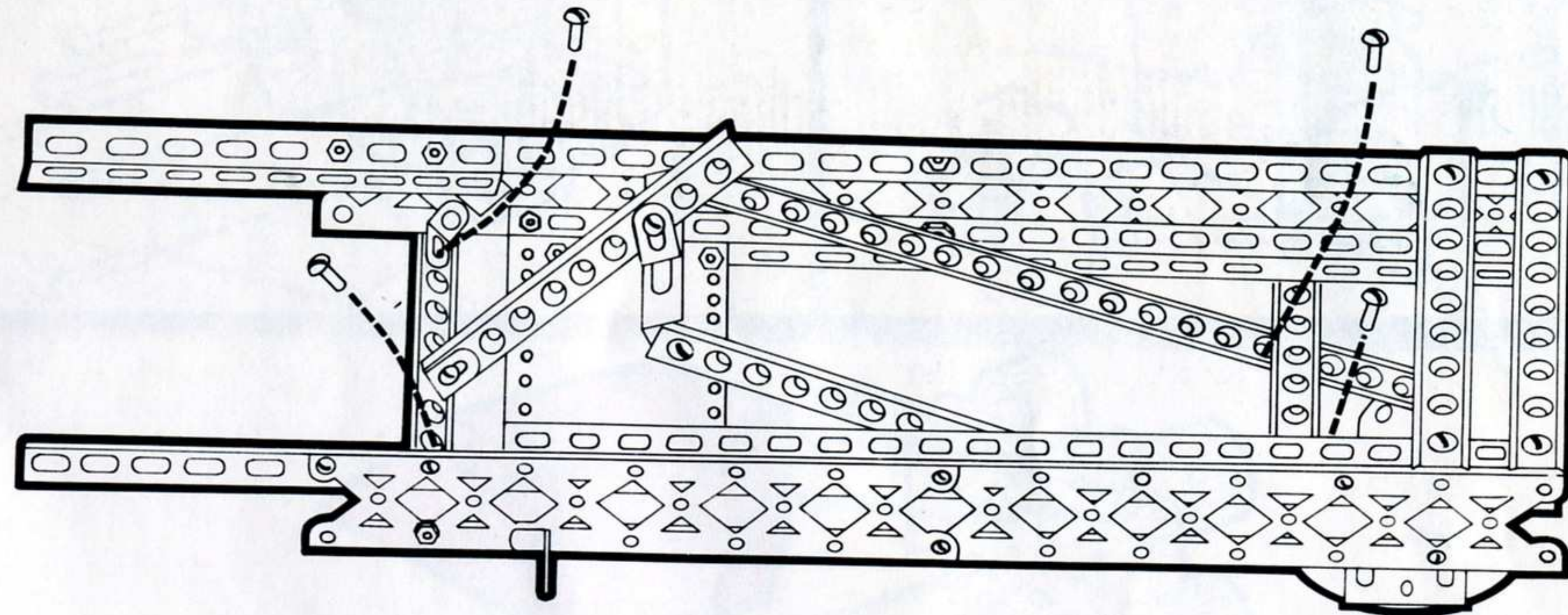

10

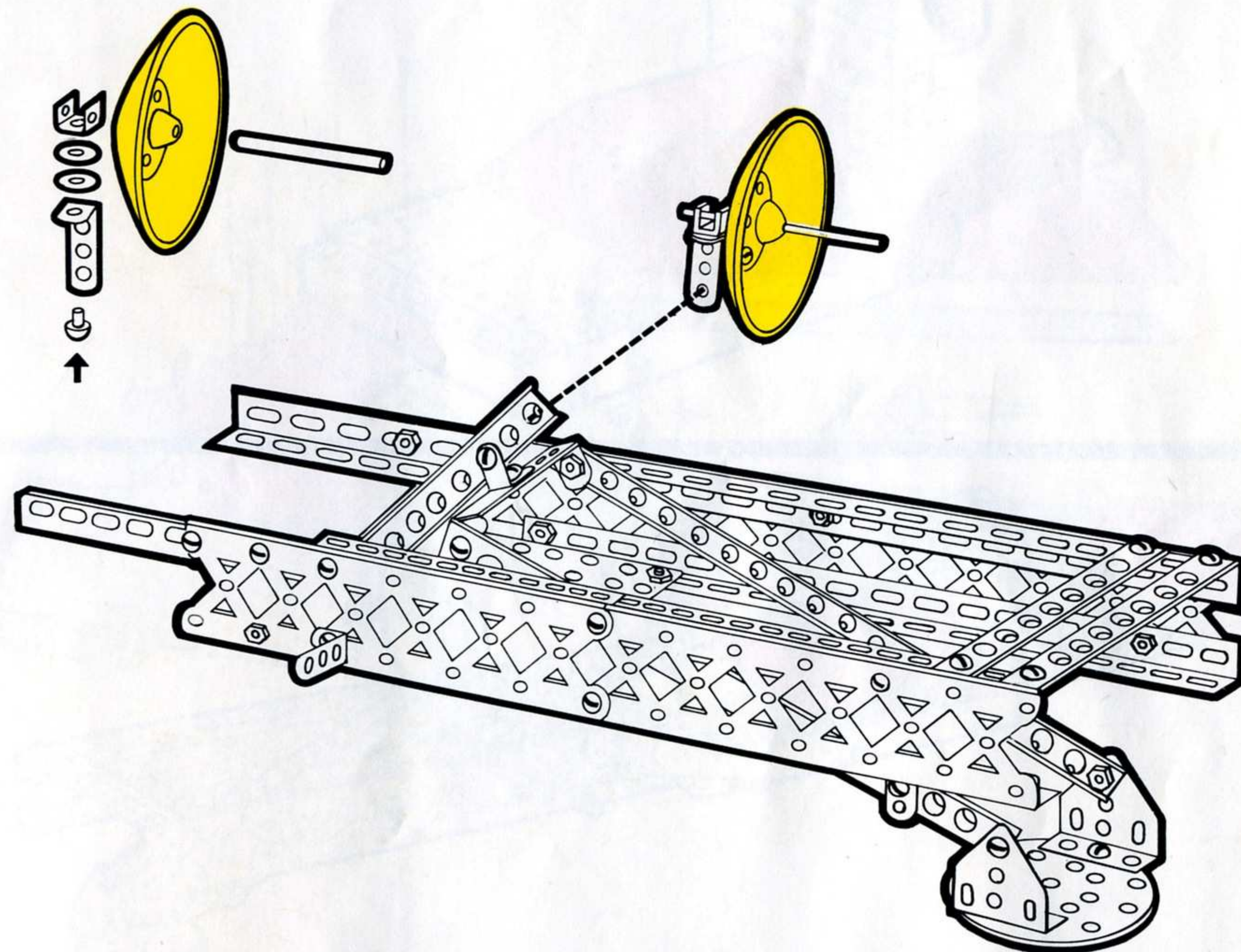



11

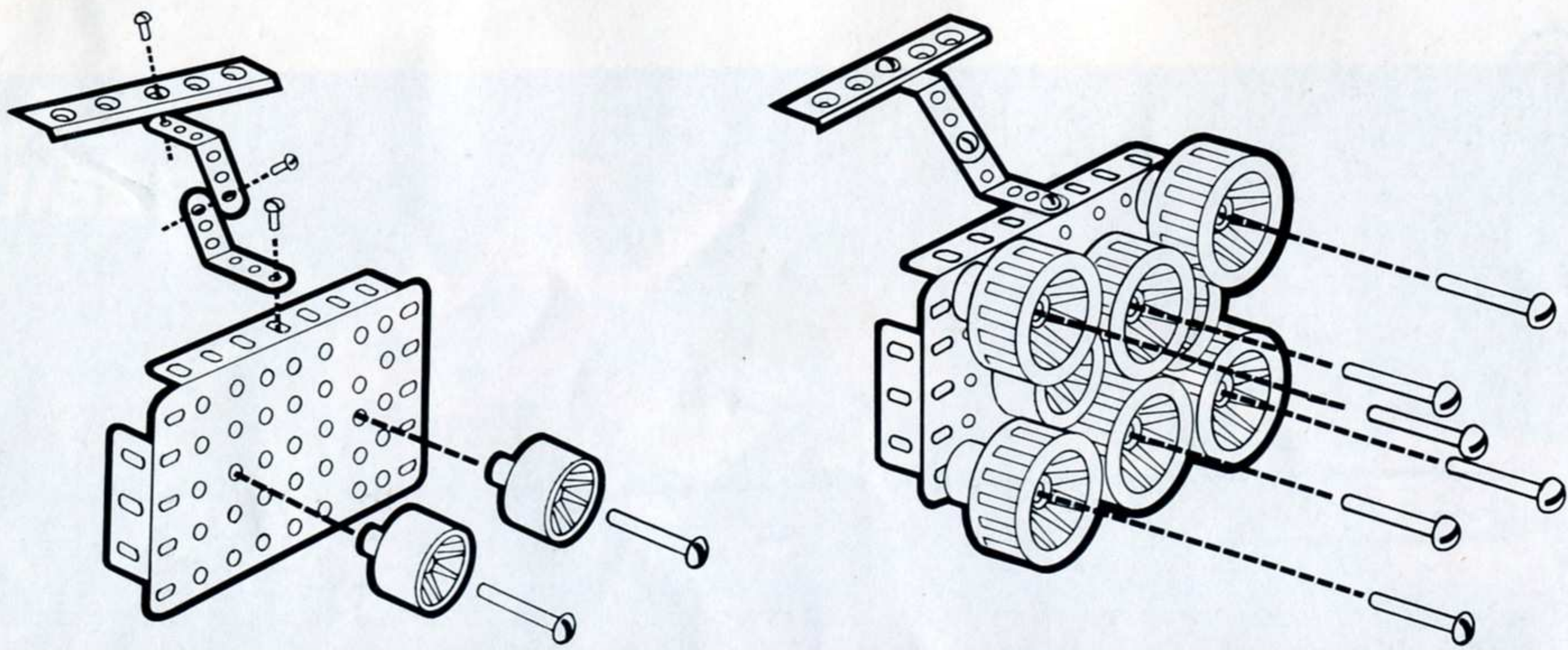

15

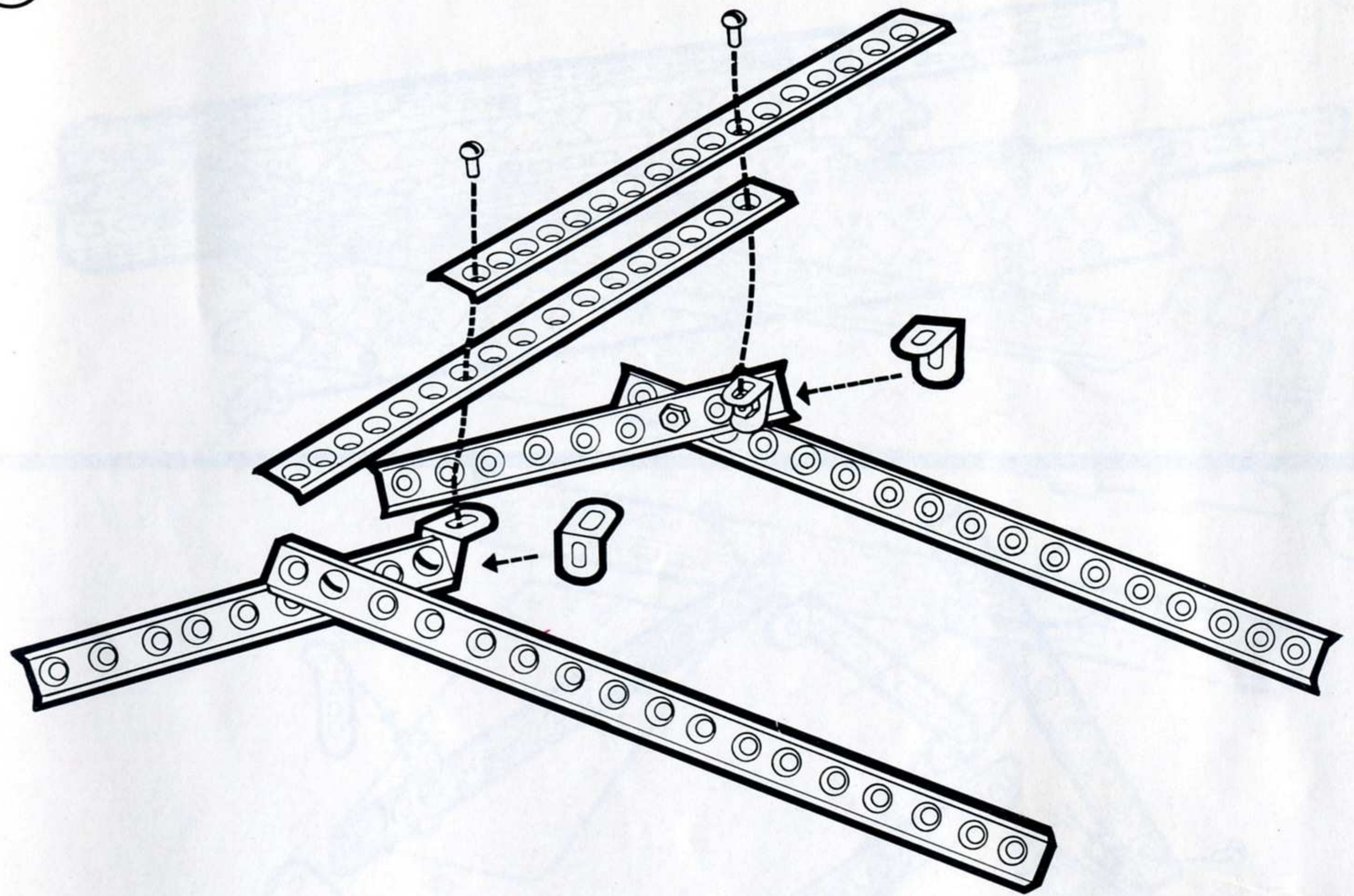

12

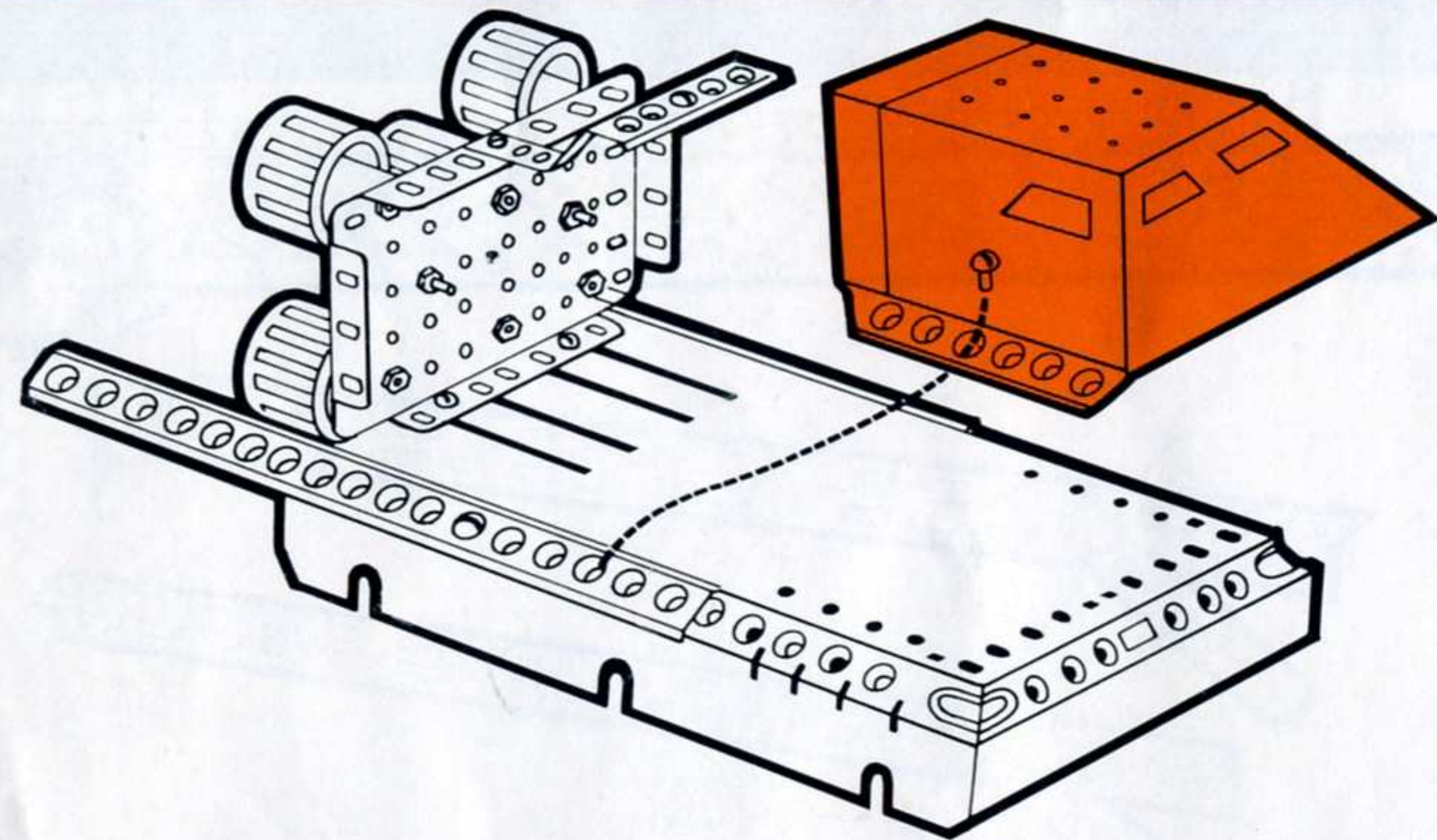

16

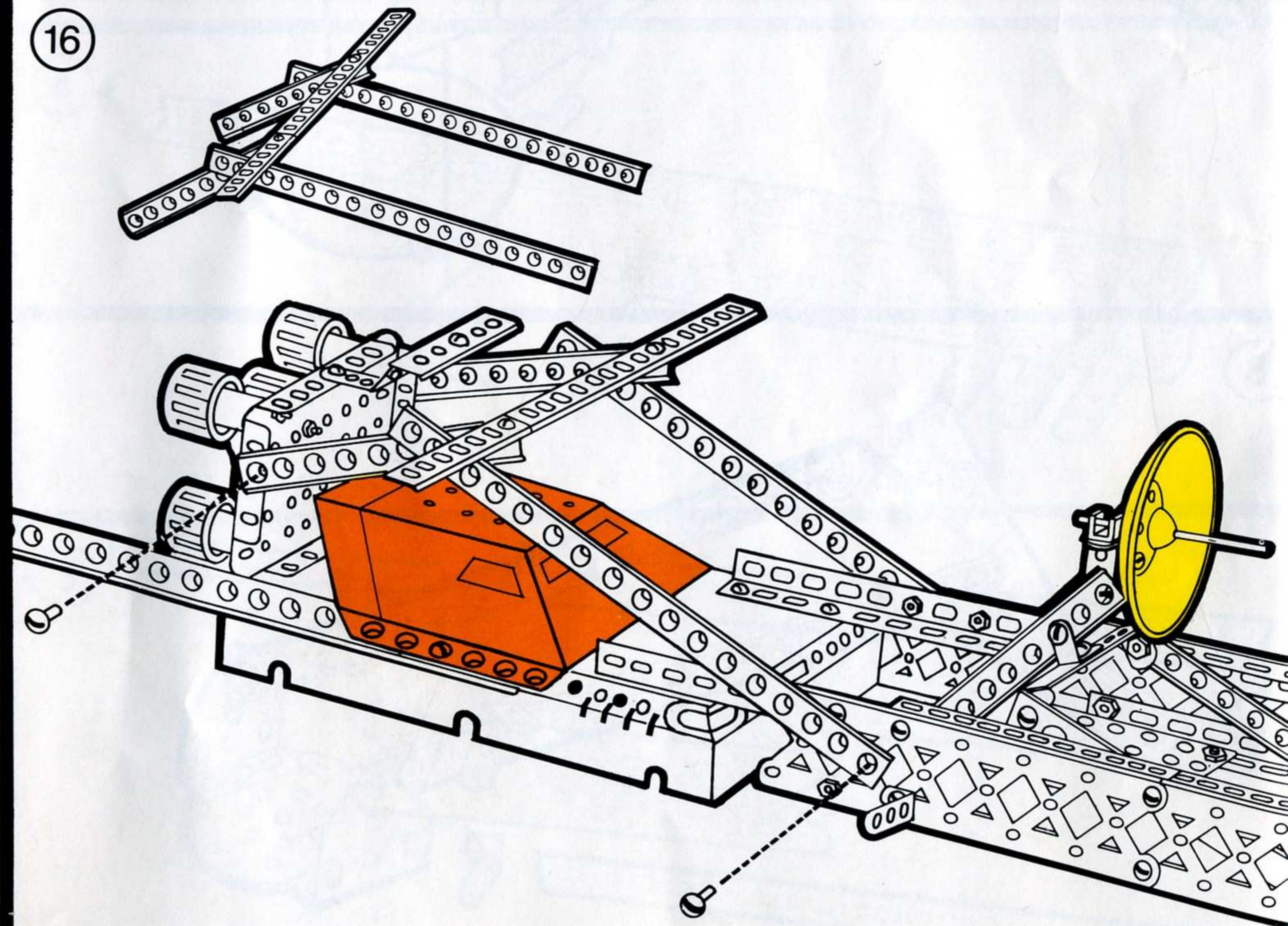

13

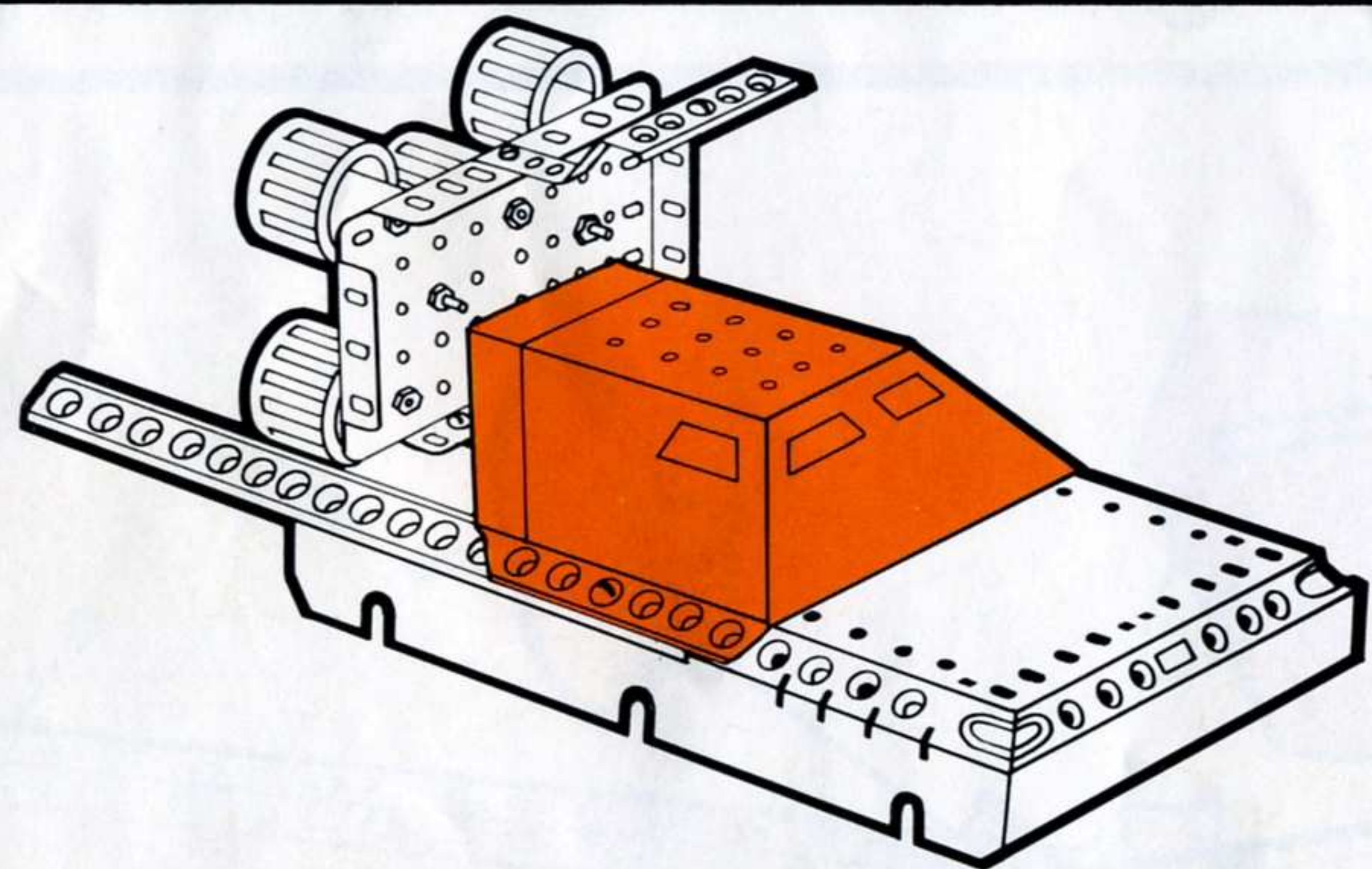

14

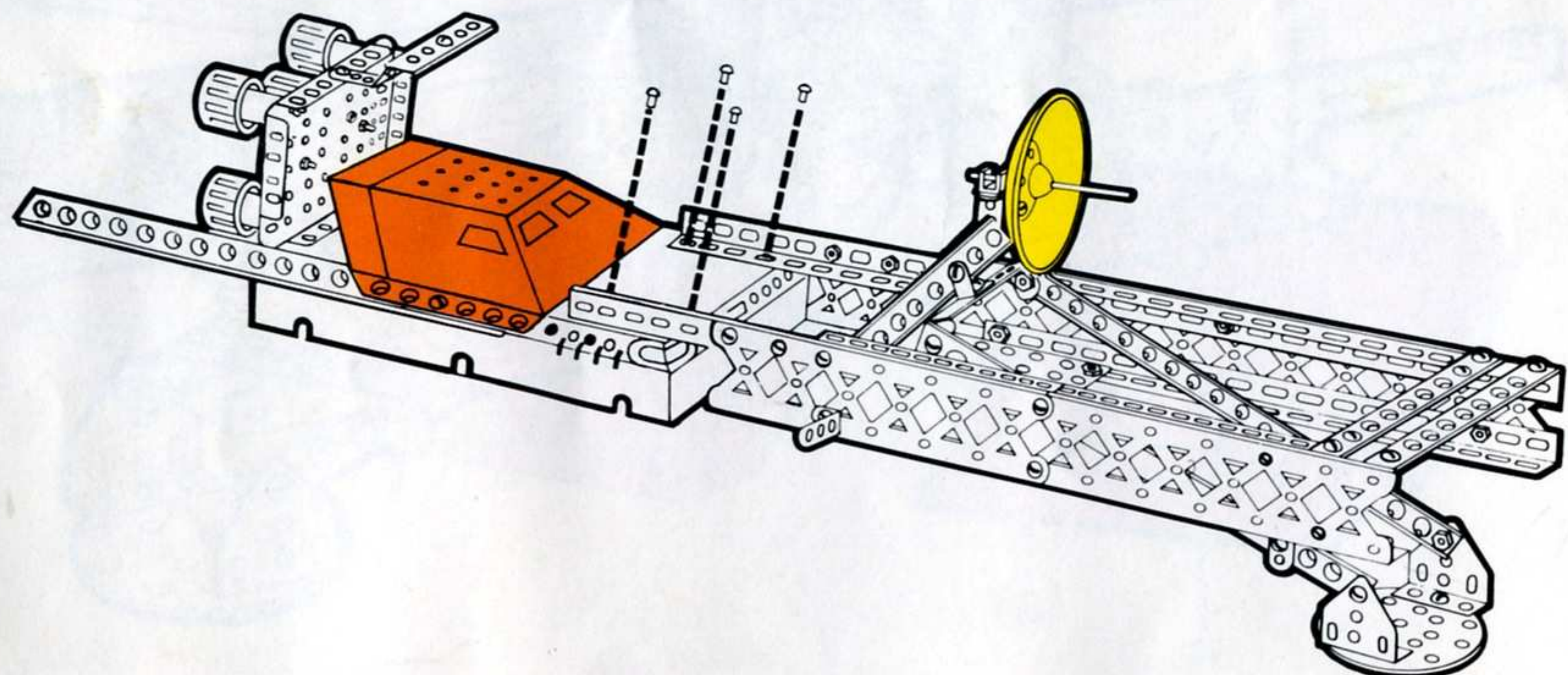



17

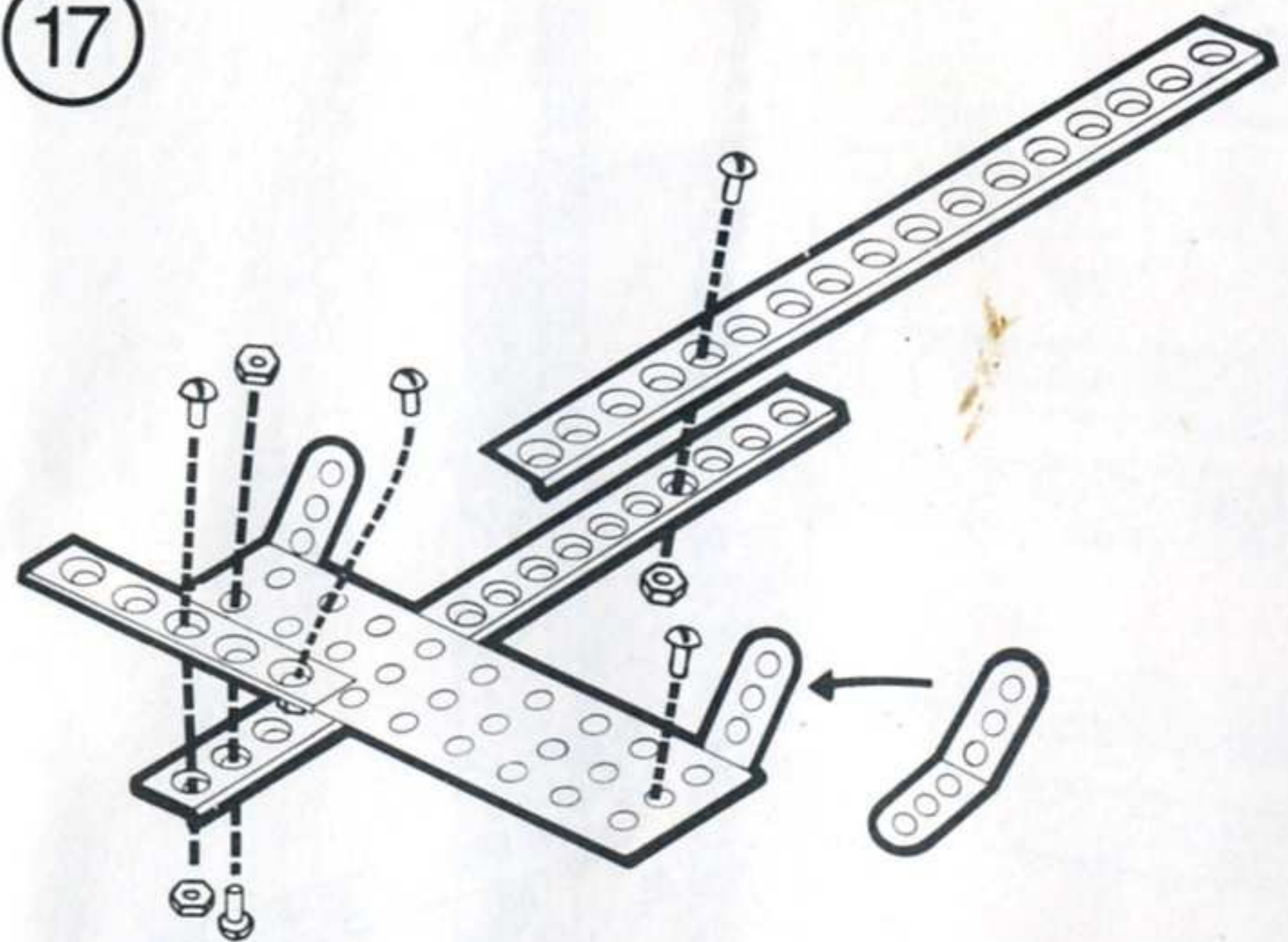

18

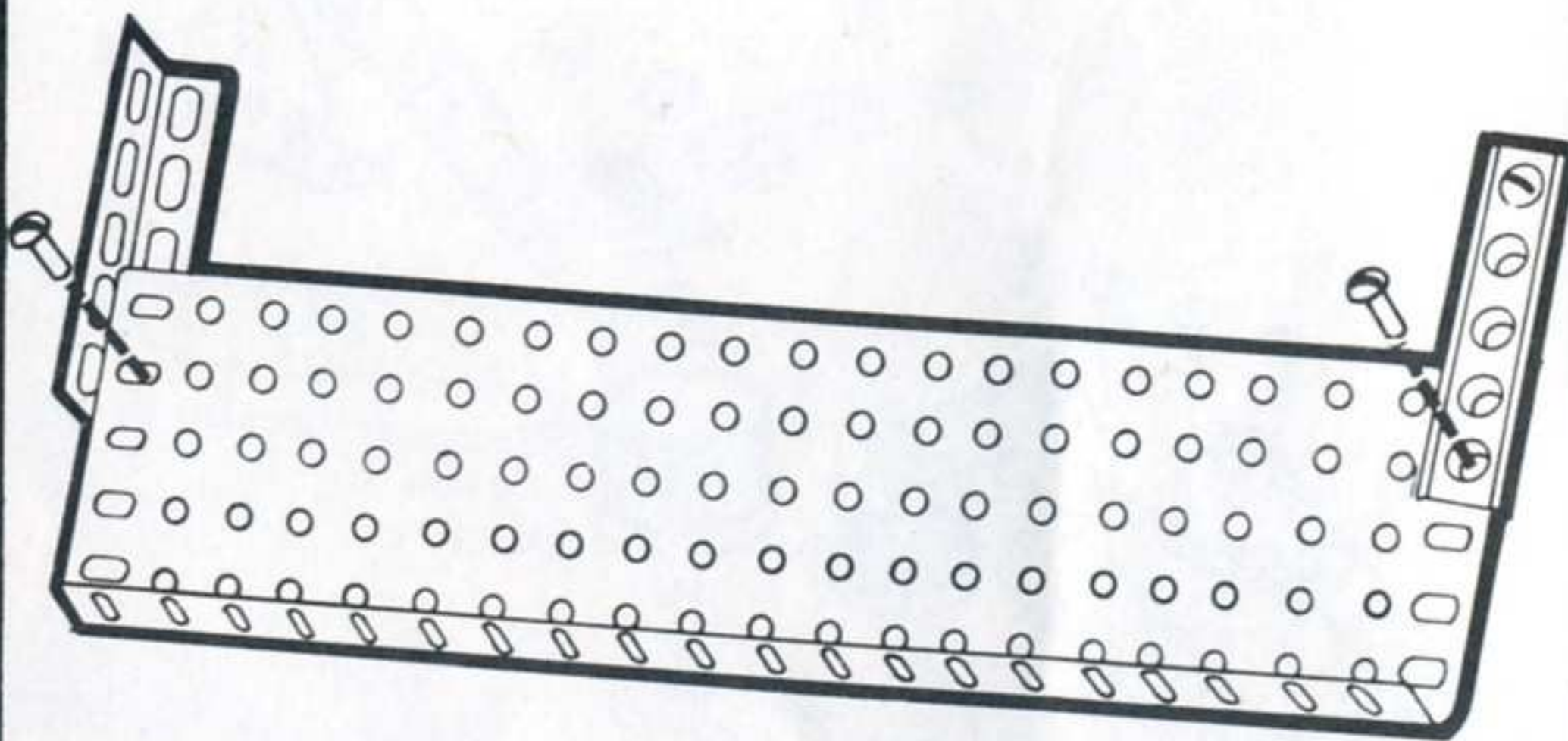

22

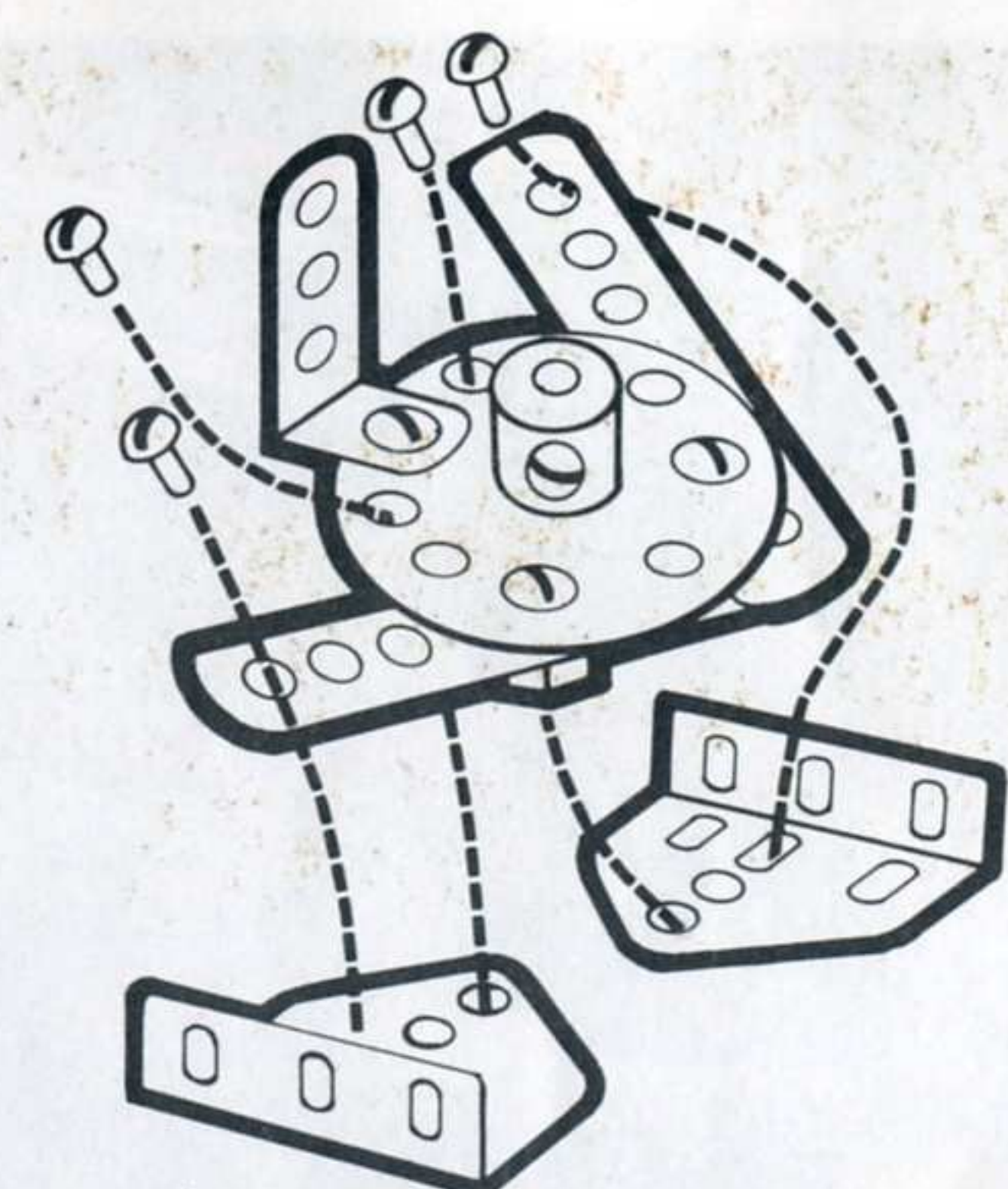

23

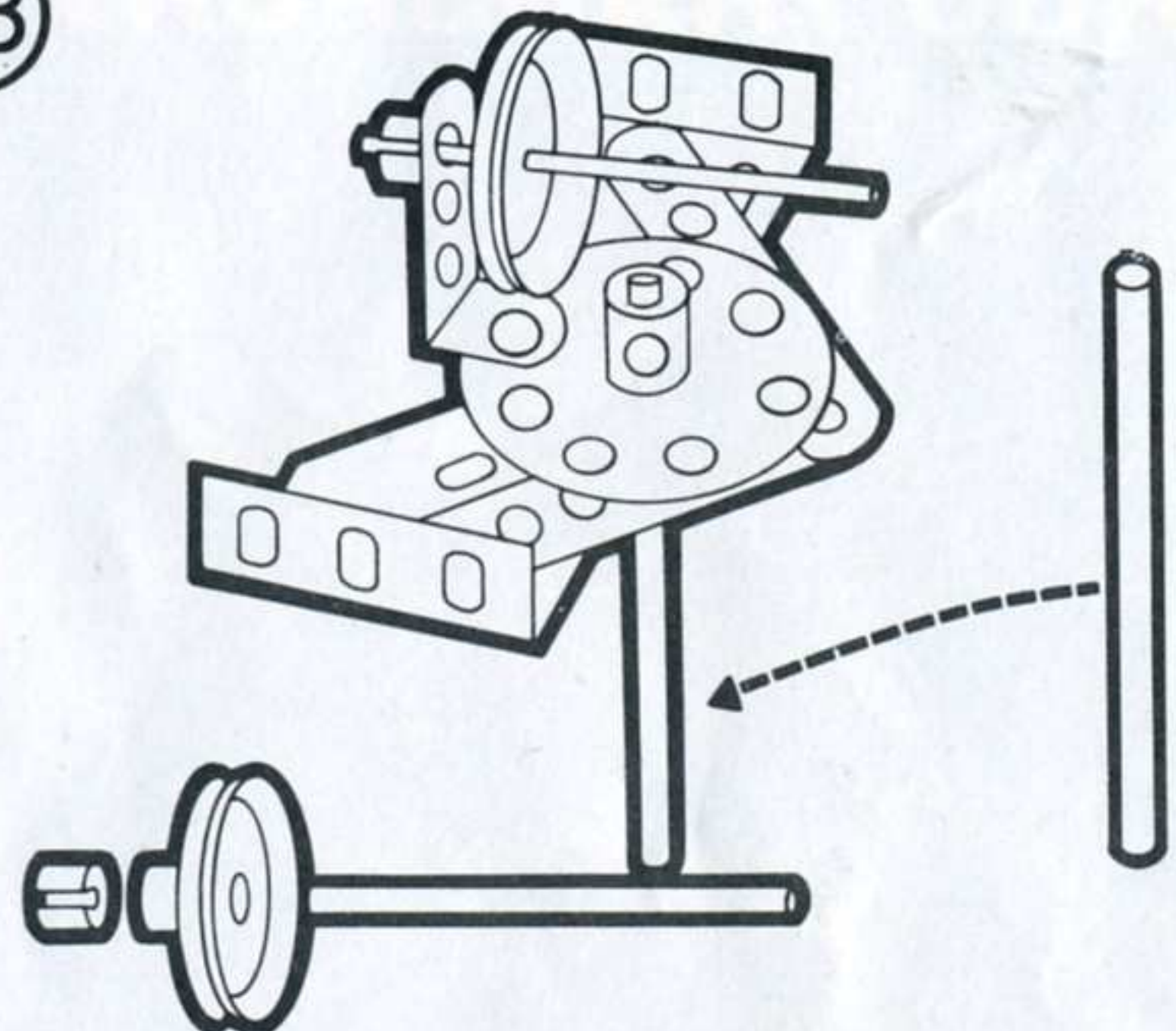

19

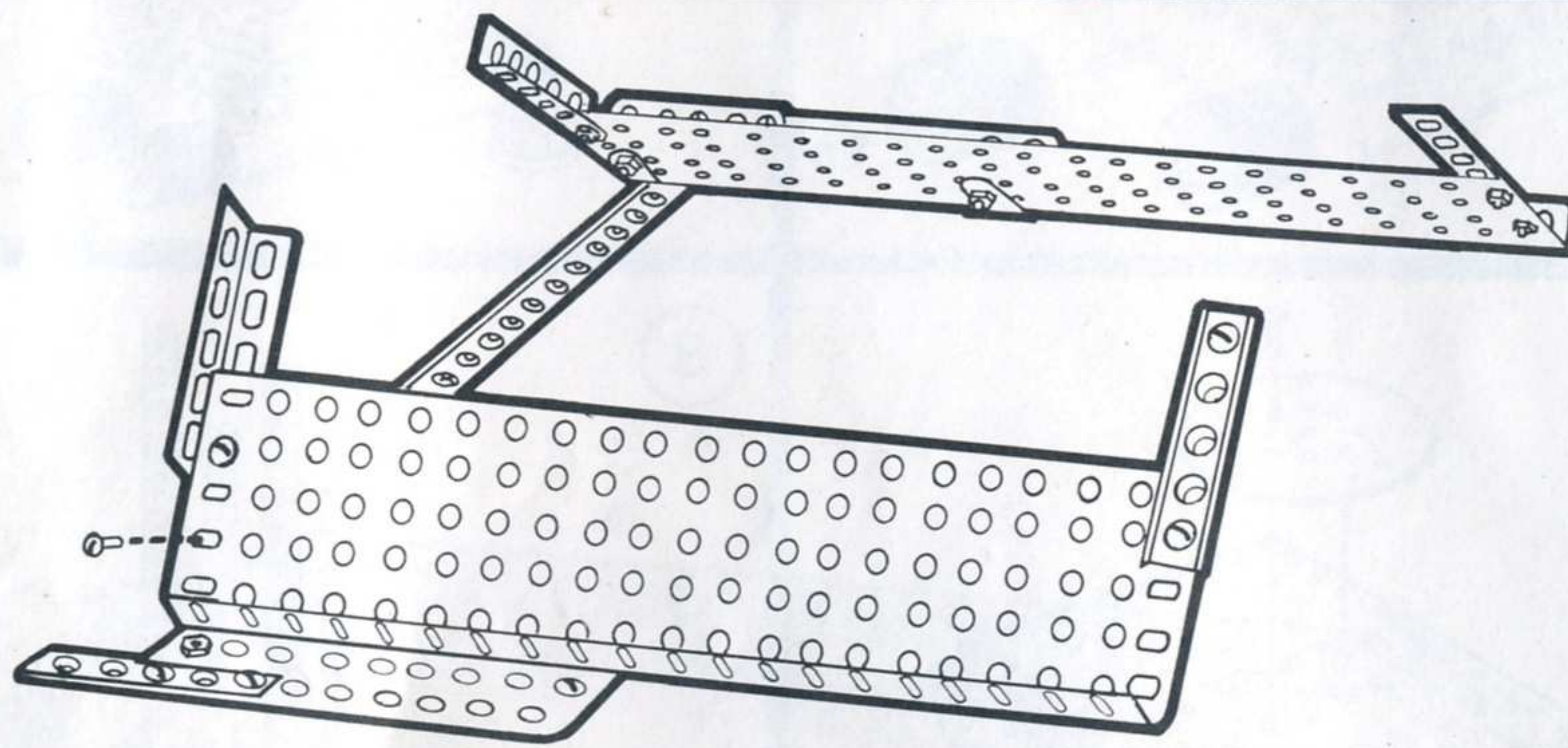

24

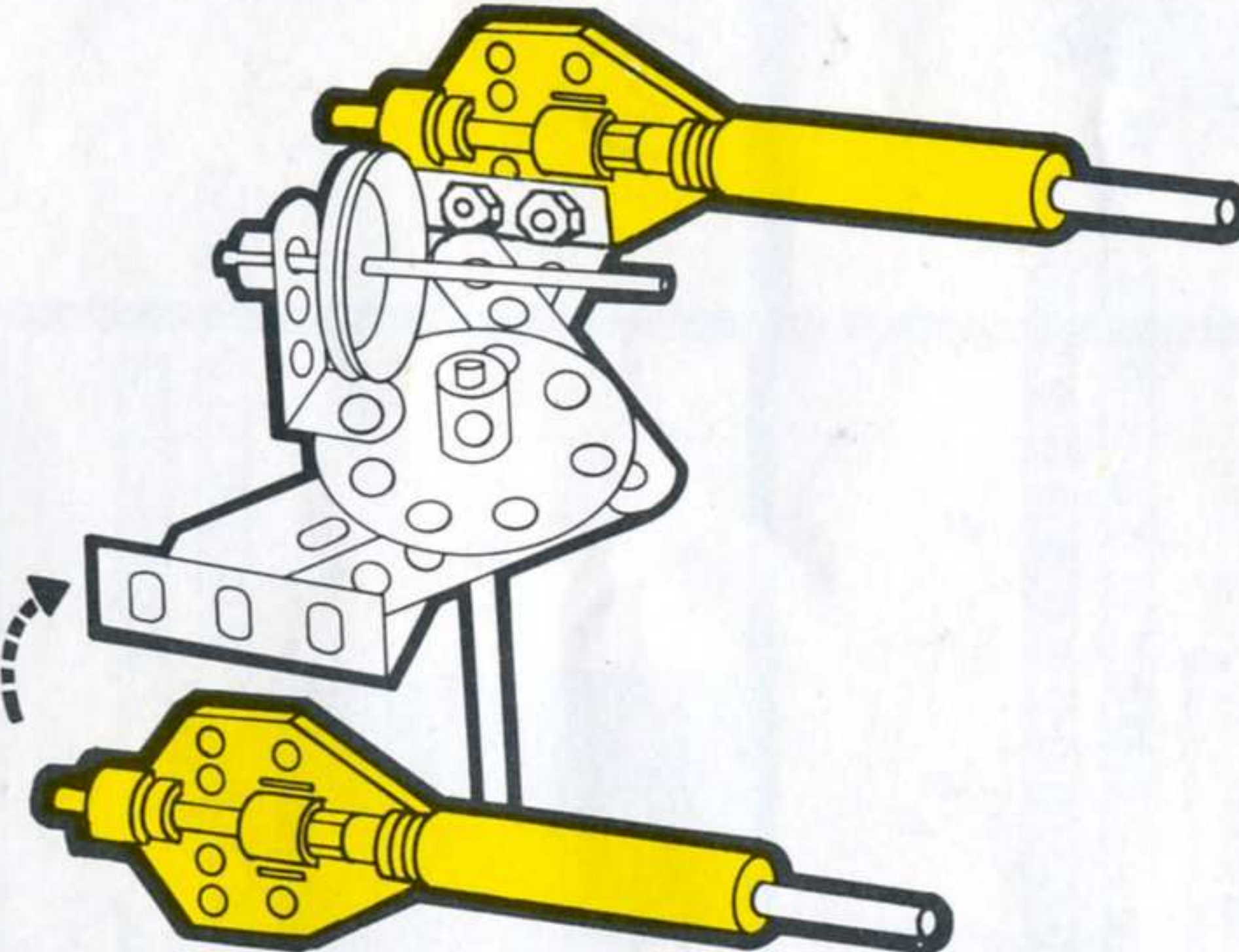

20

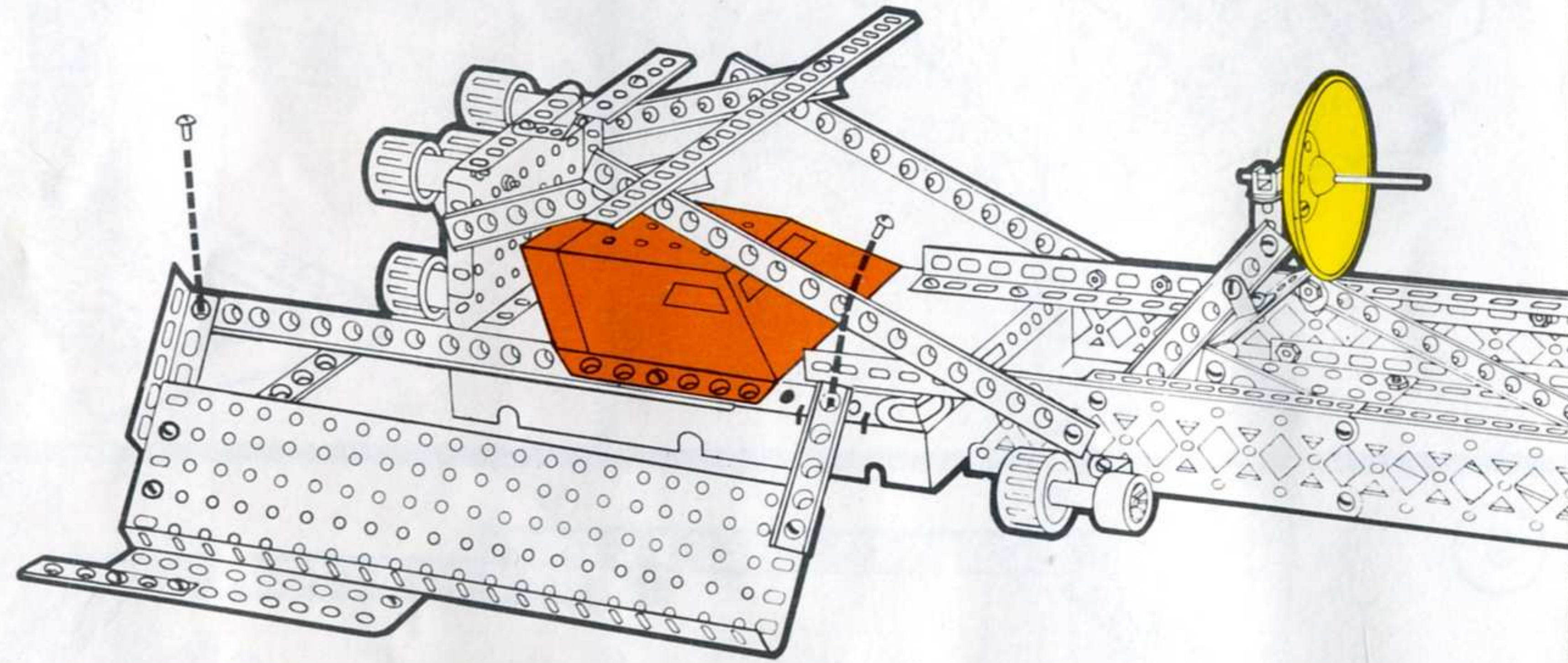

25

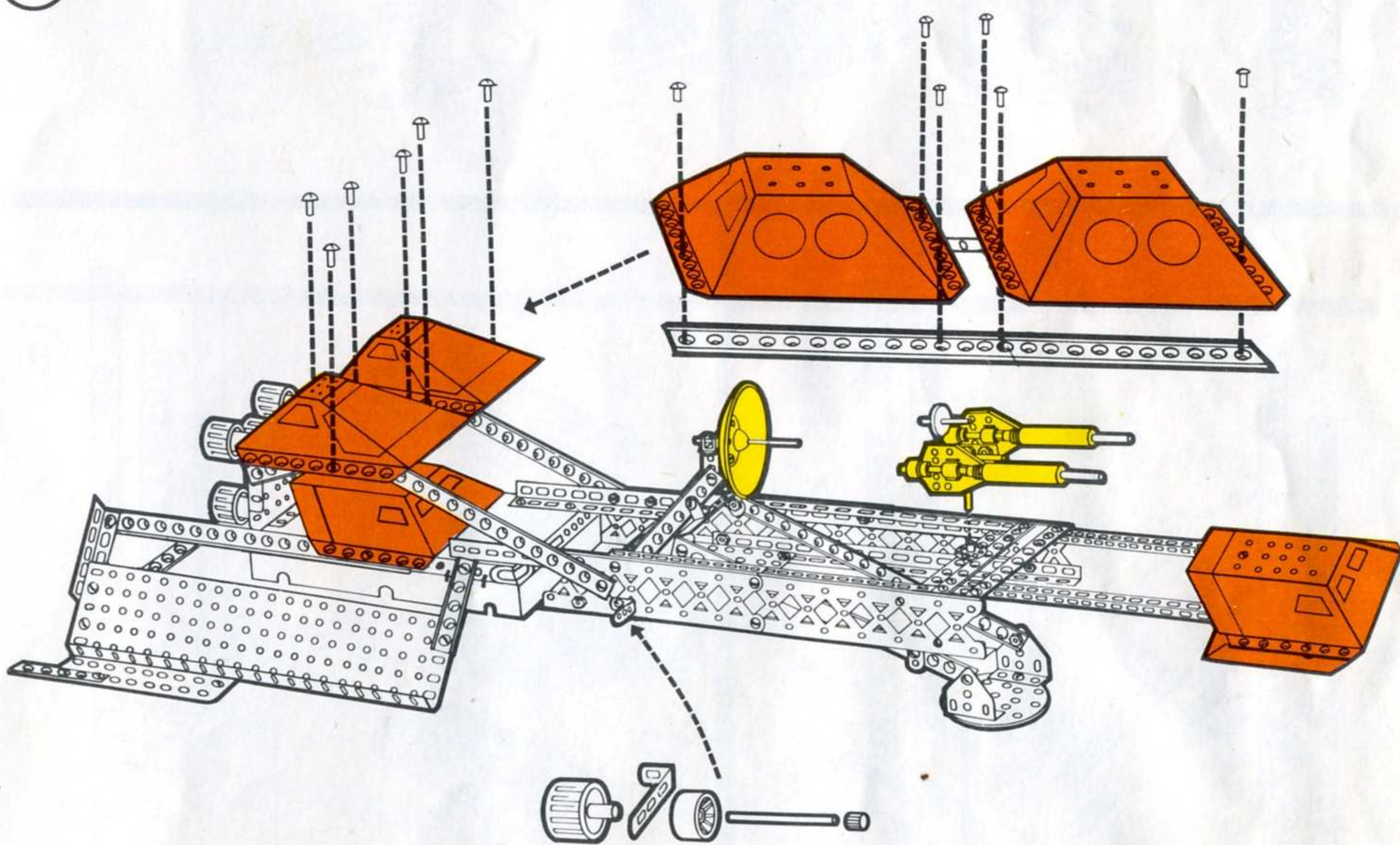

21

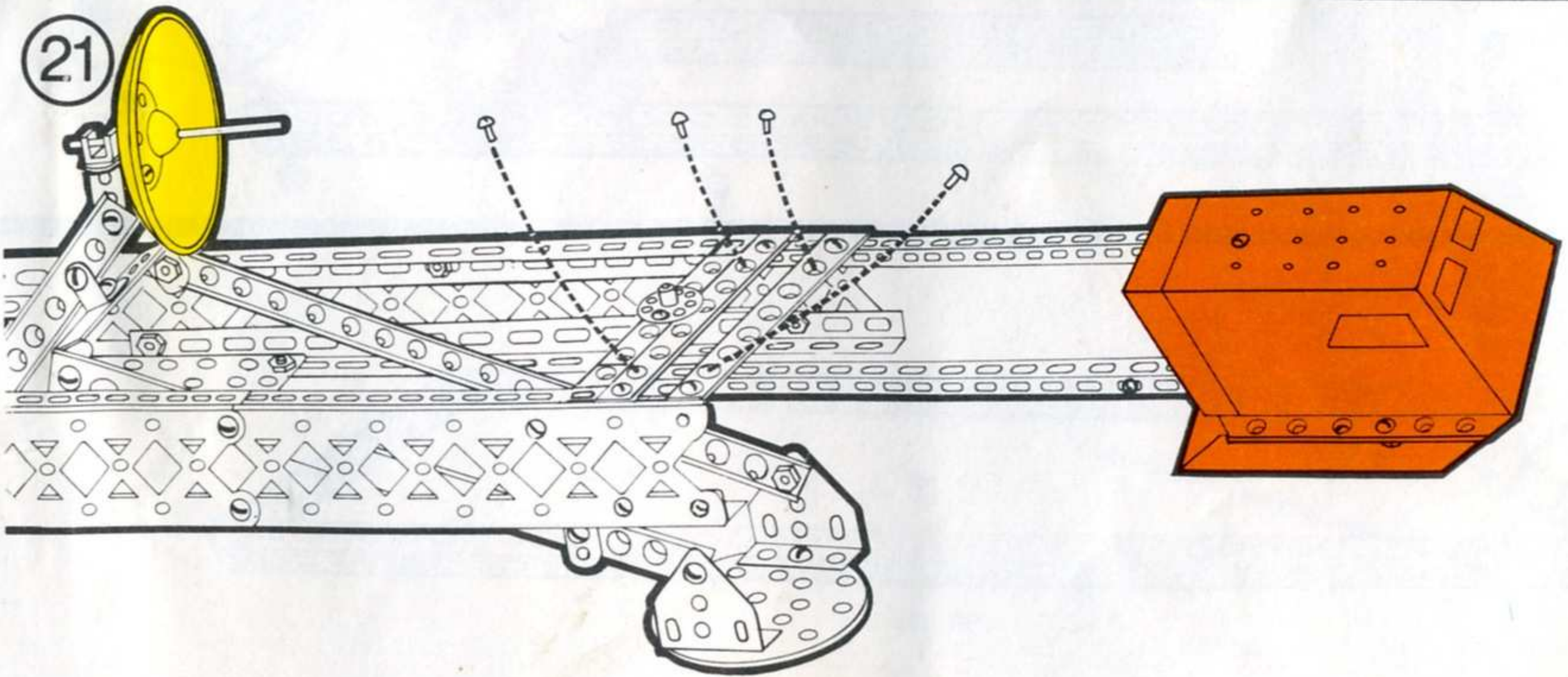



# CARGO TRANSPORT

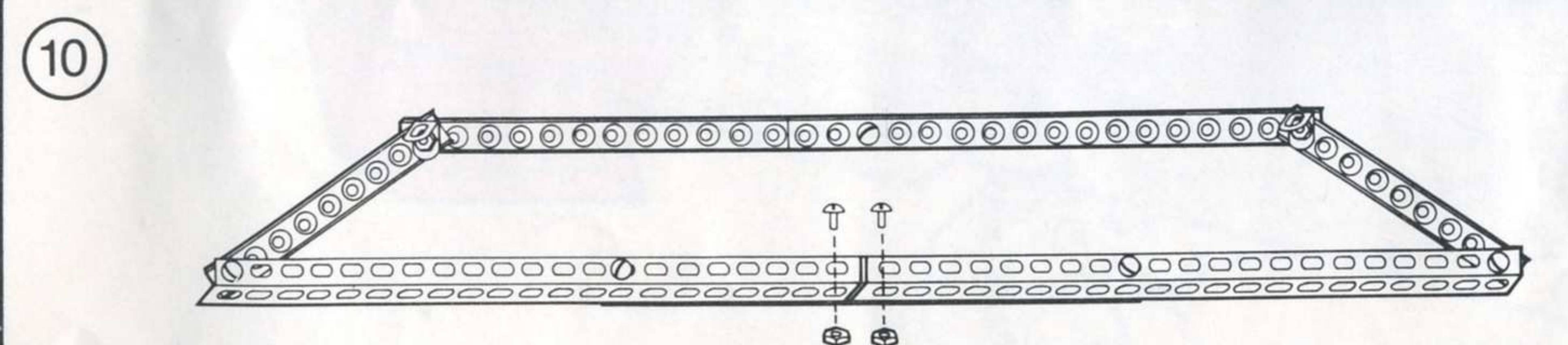
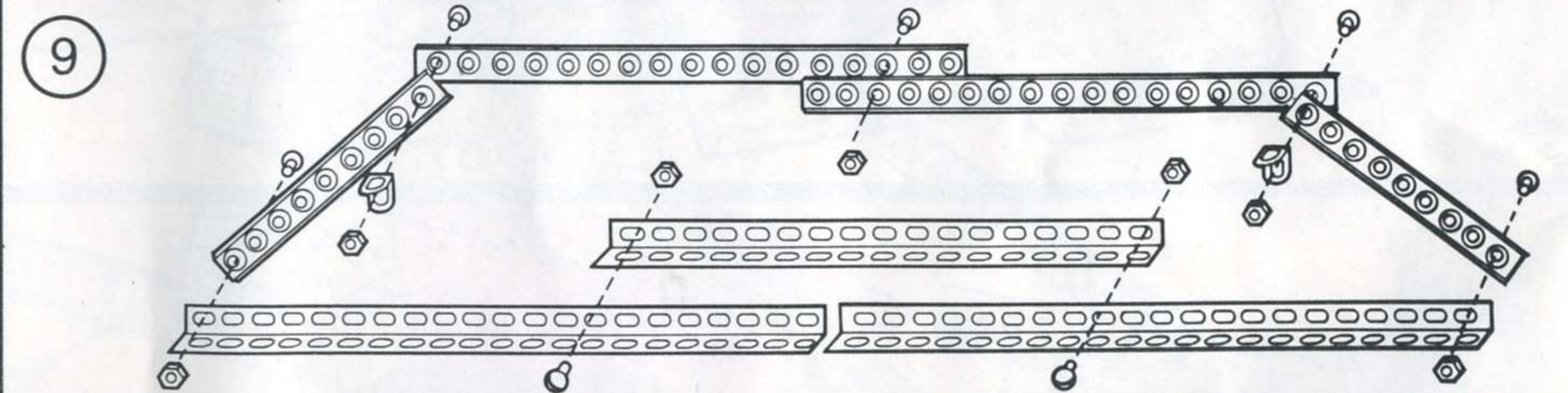
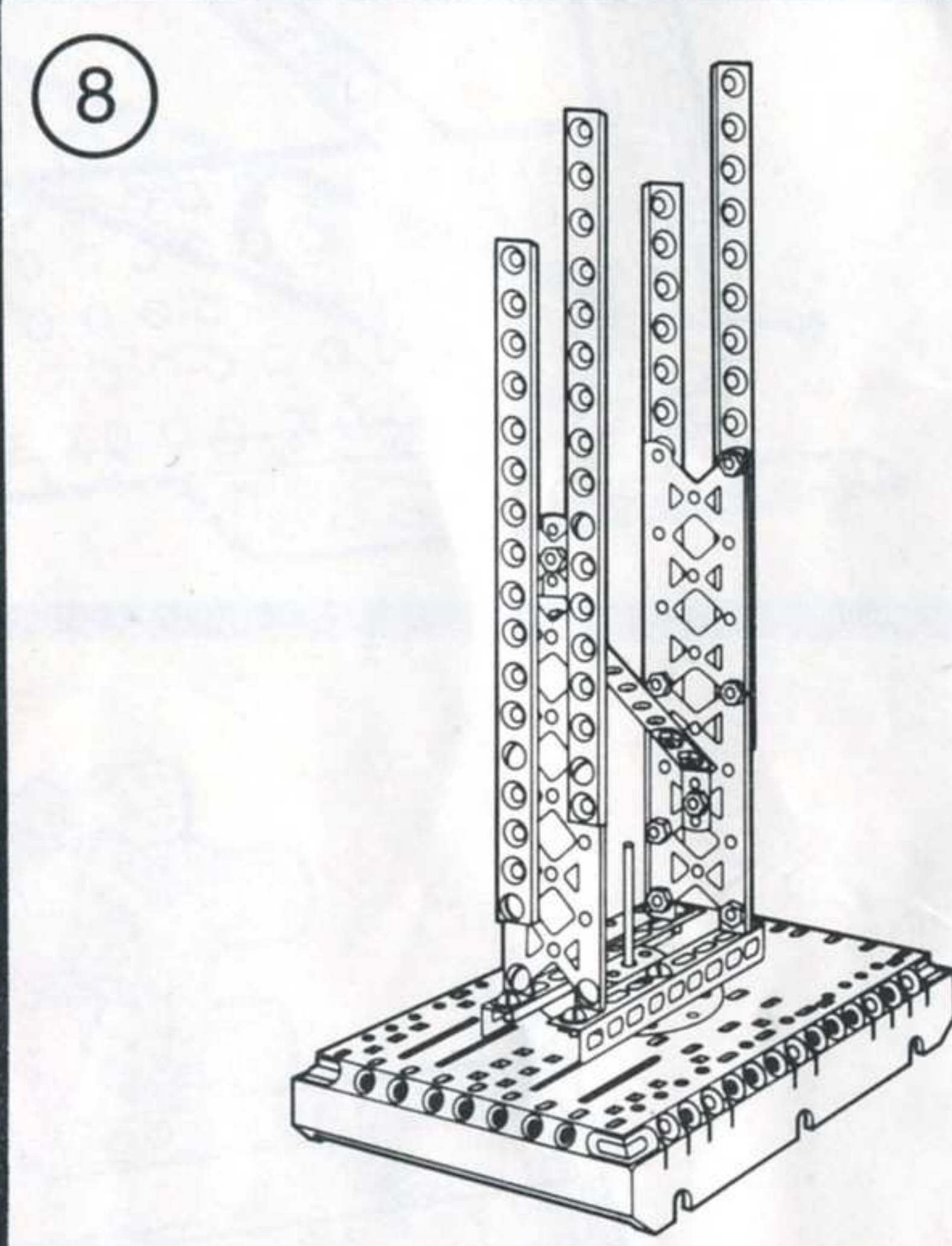
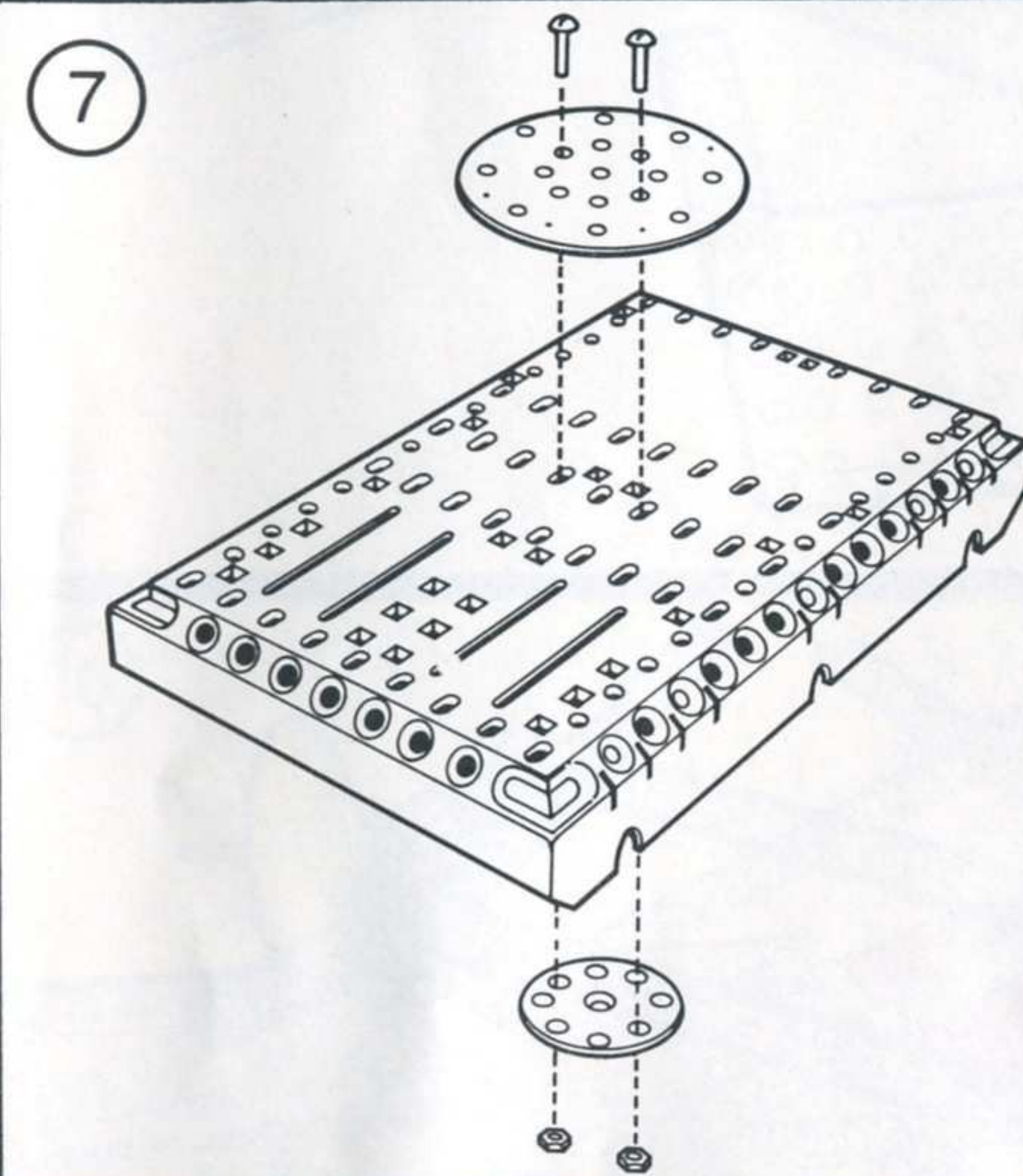
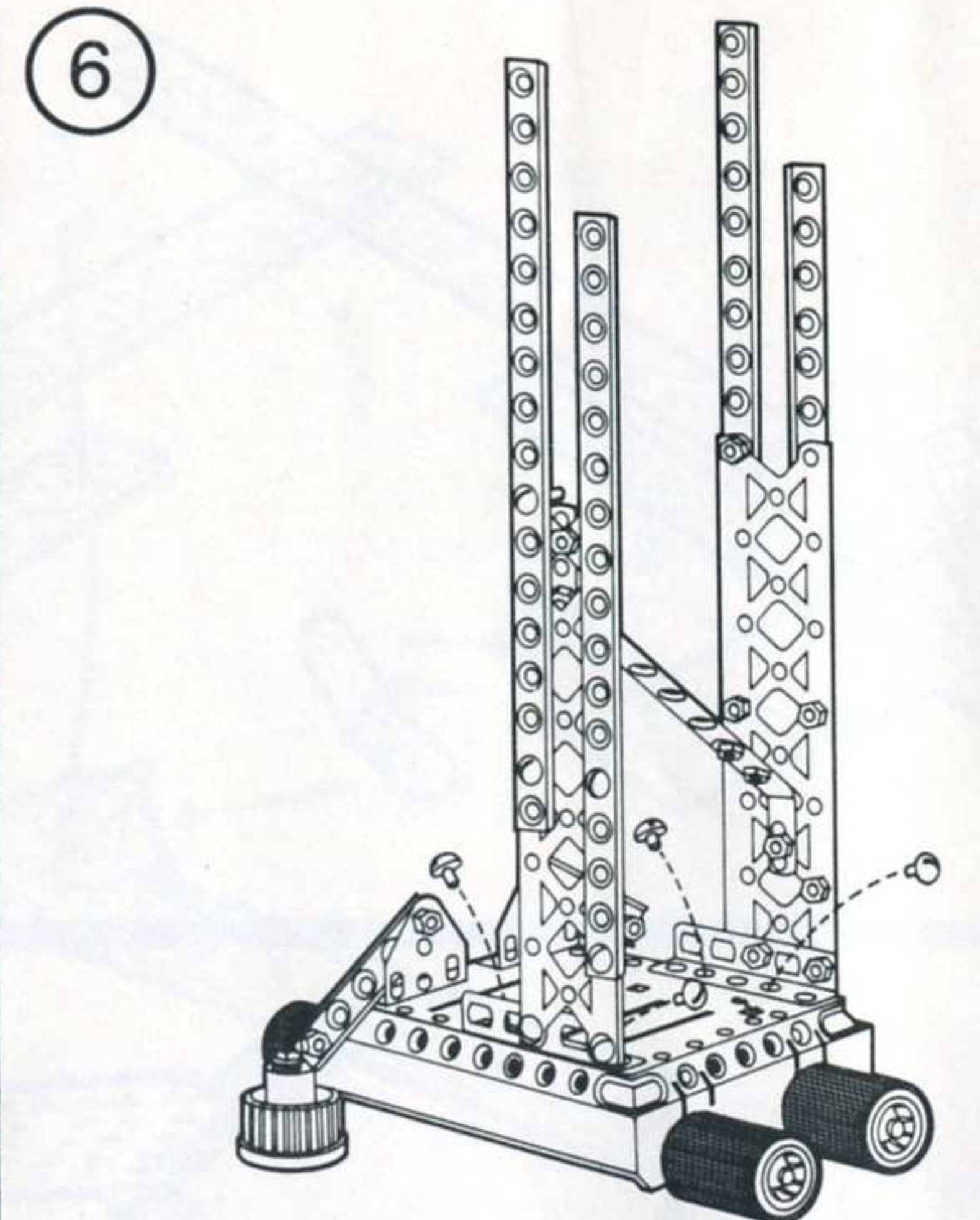
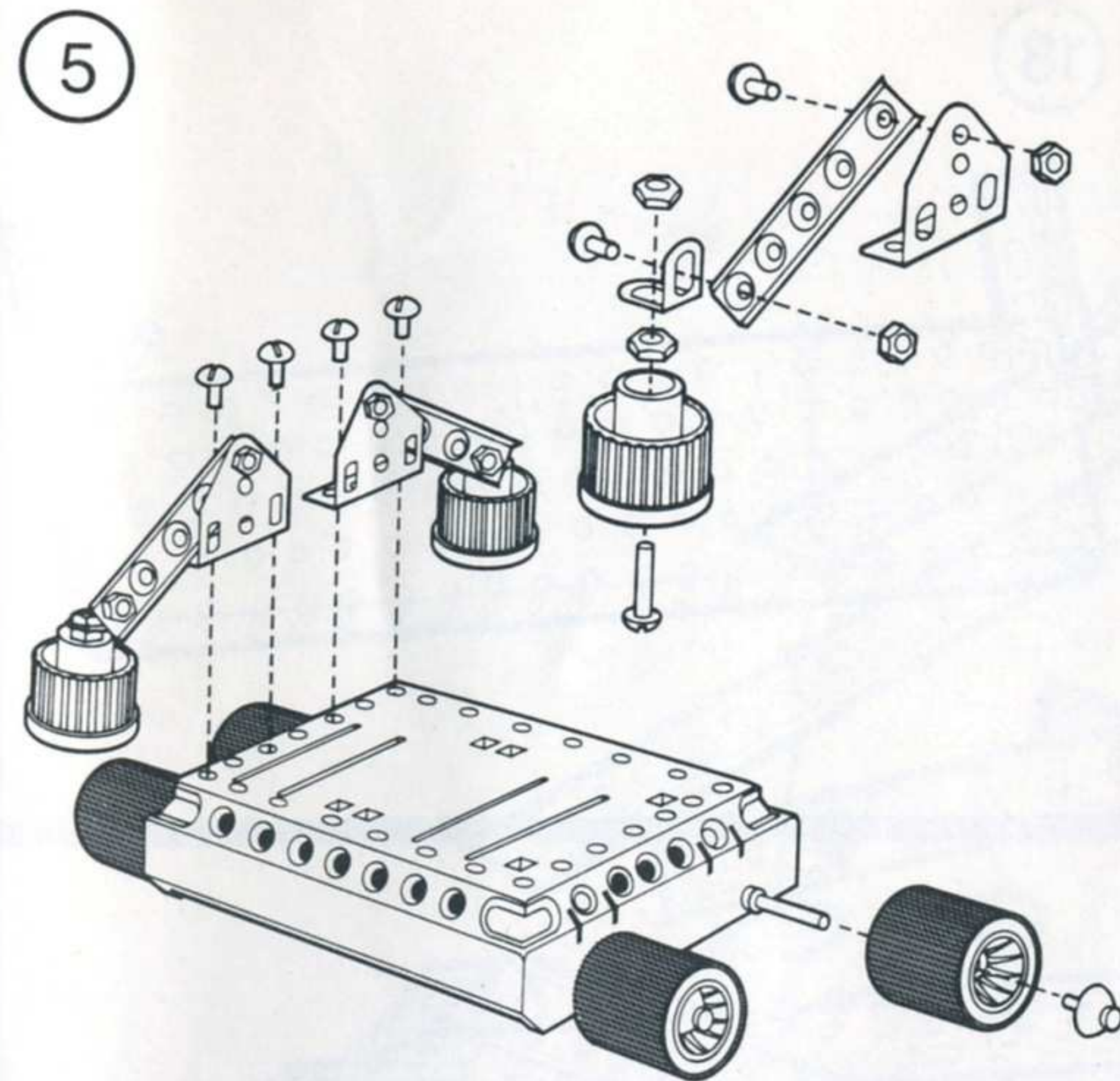
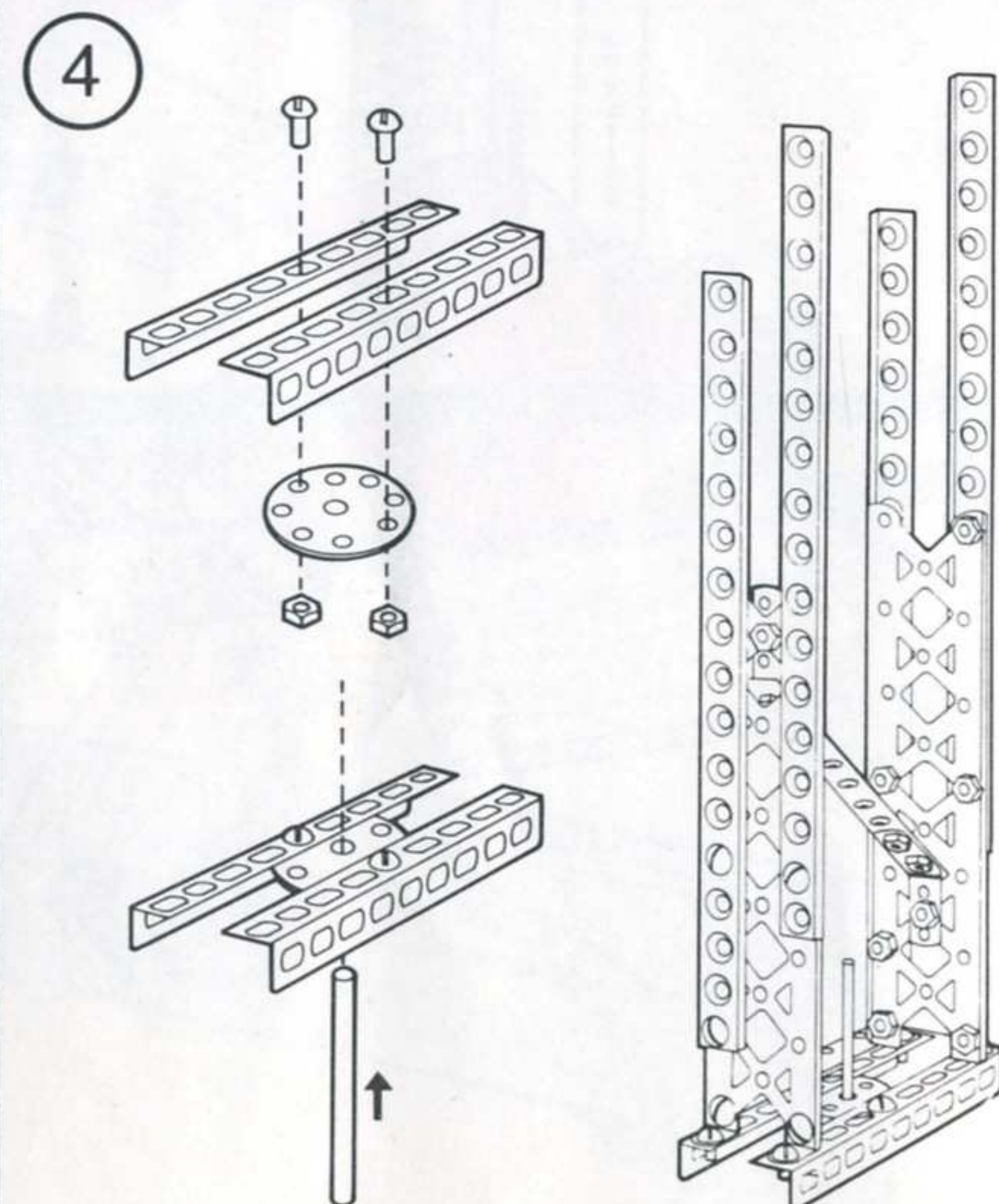
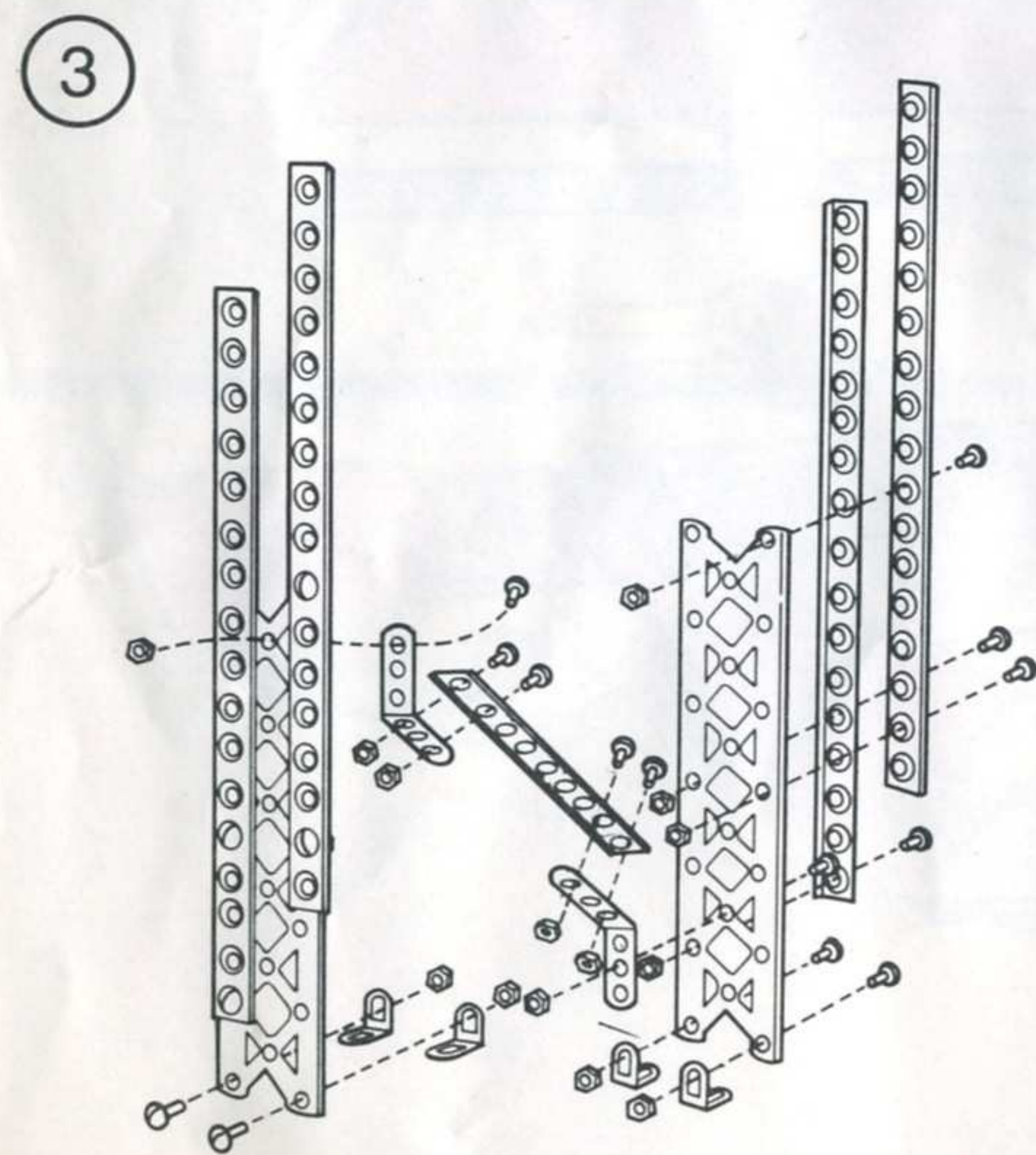
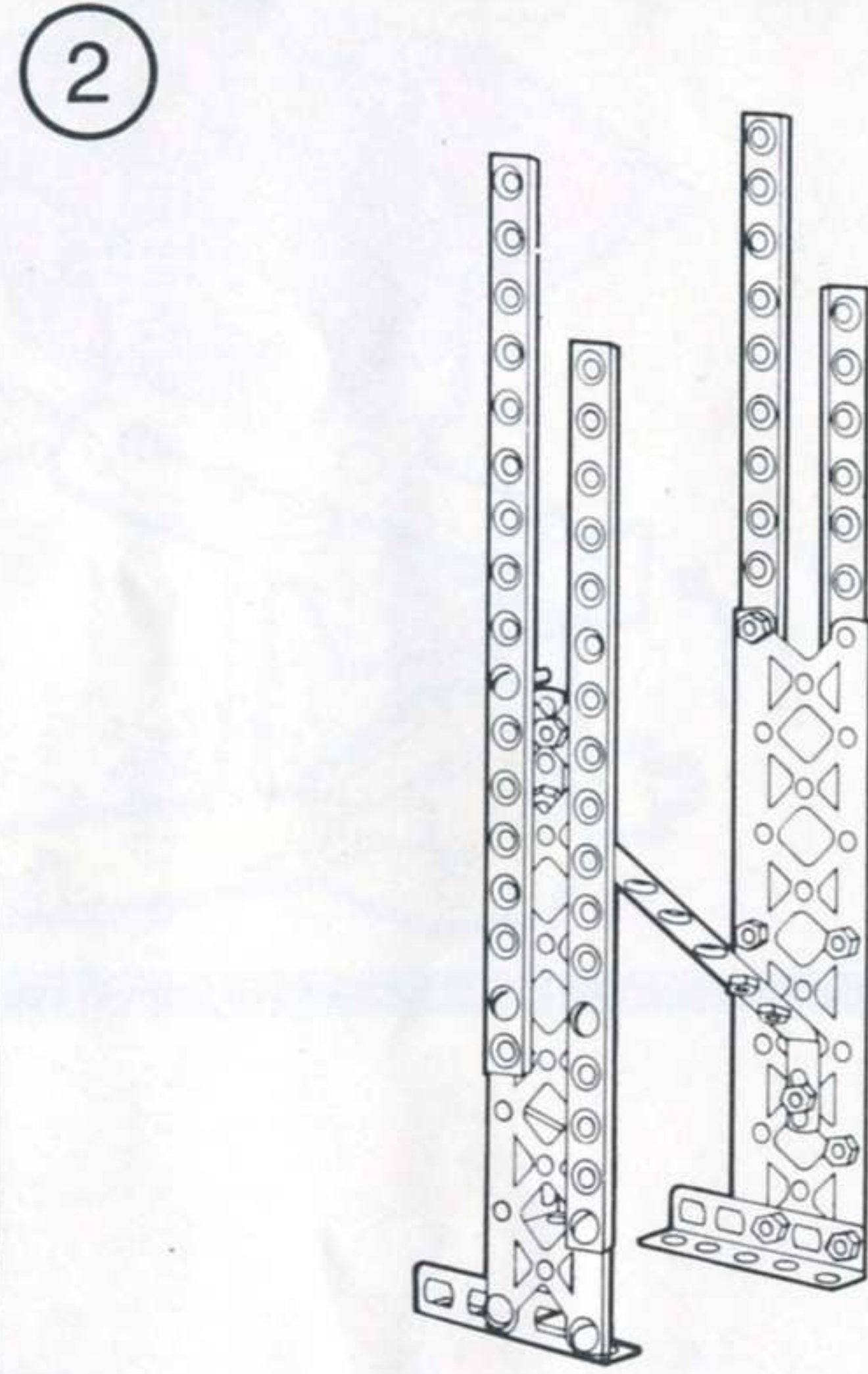
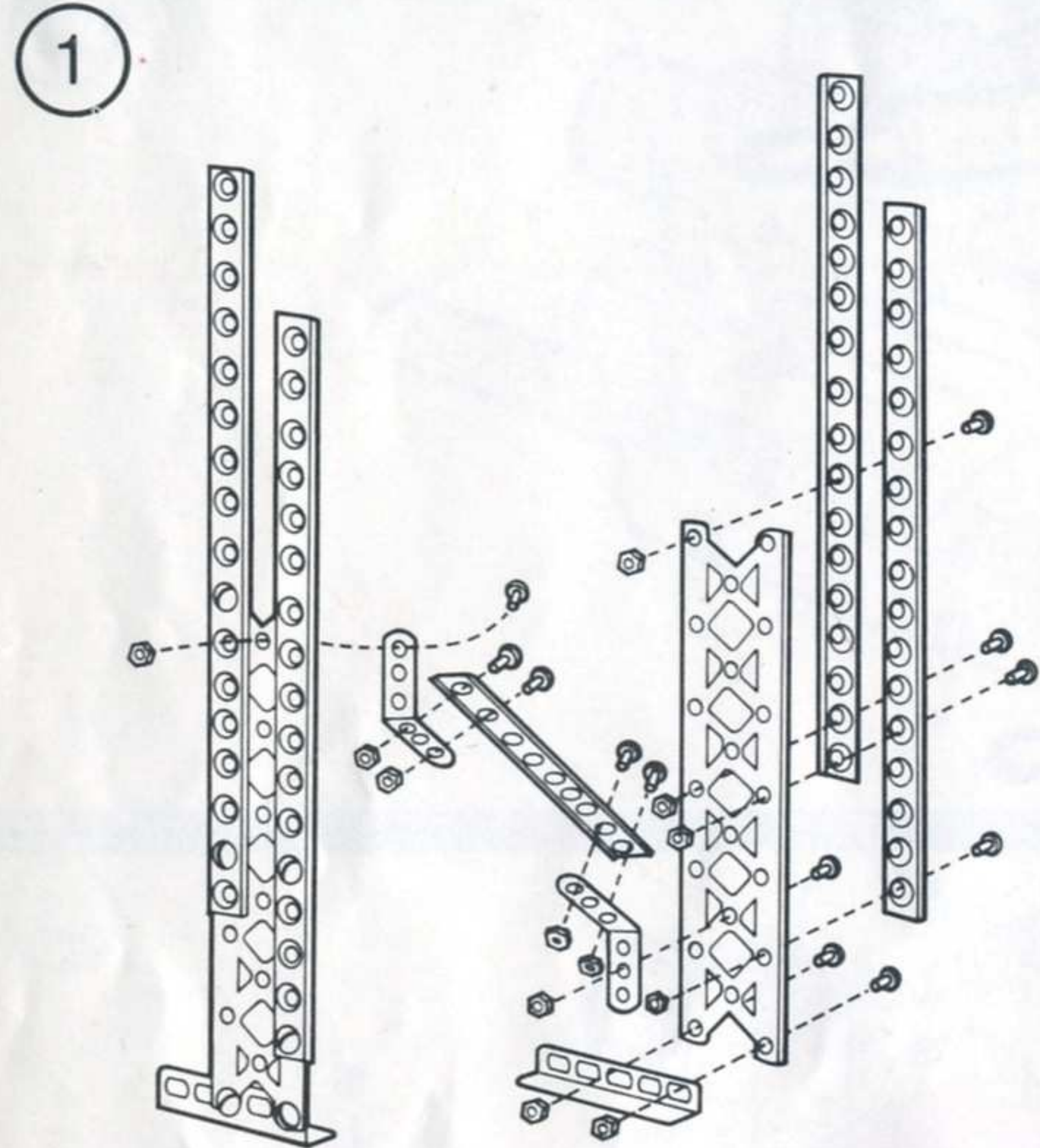



11

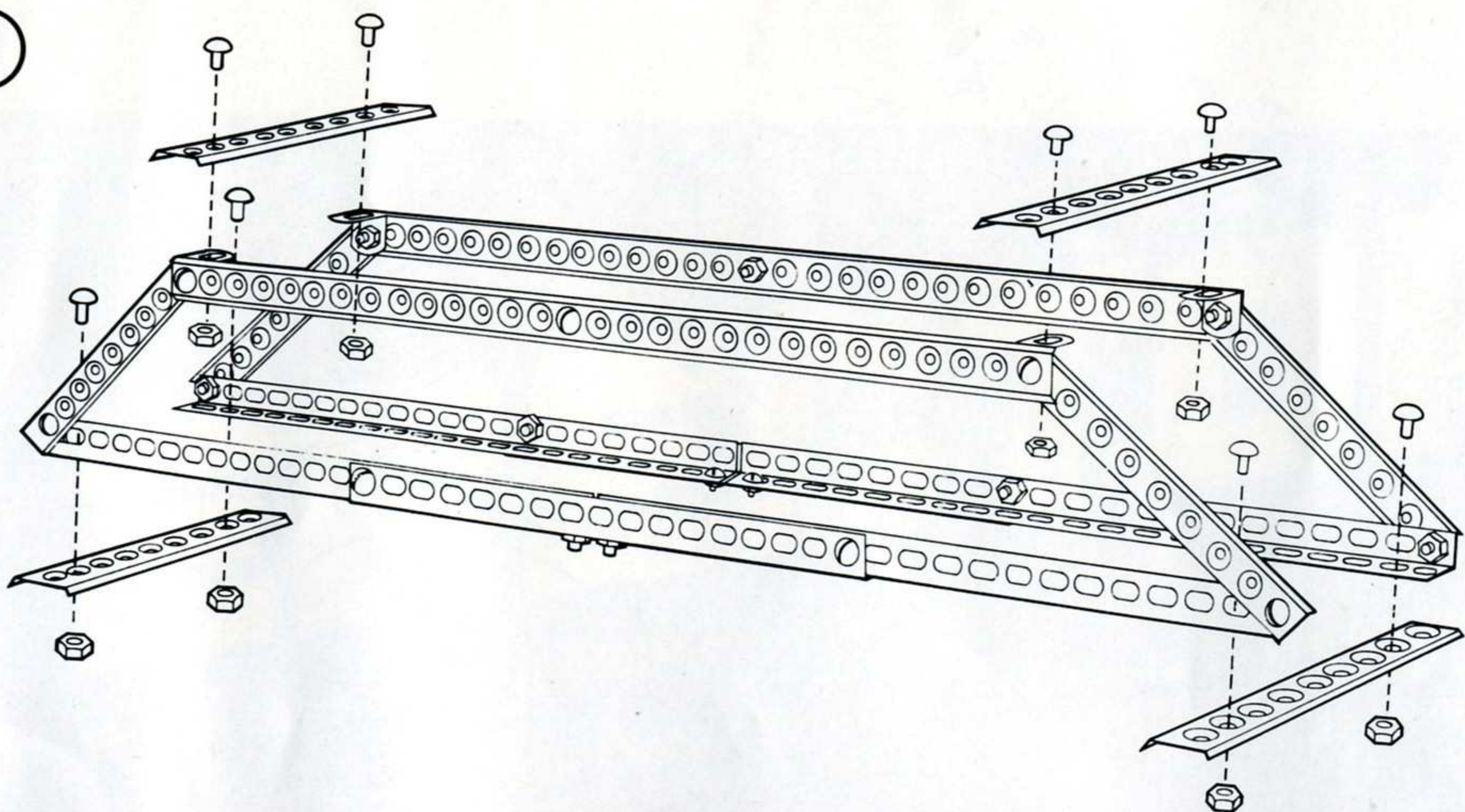

13

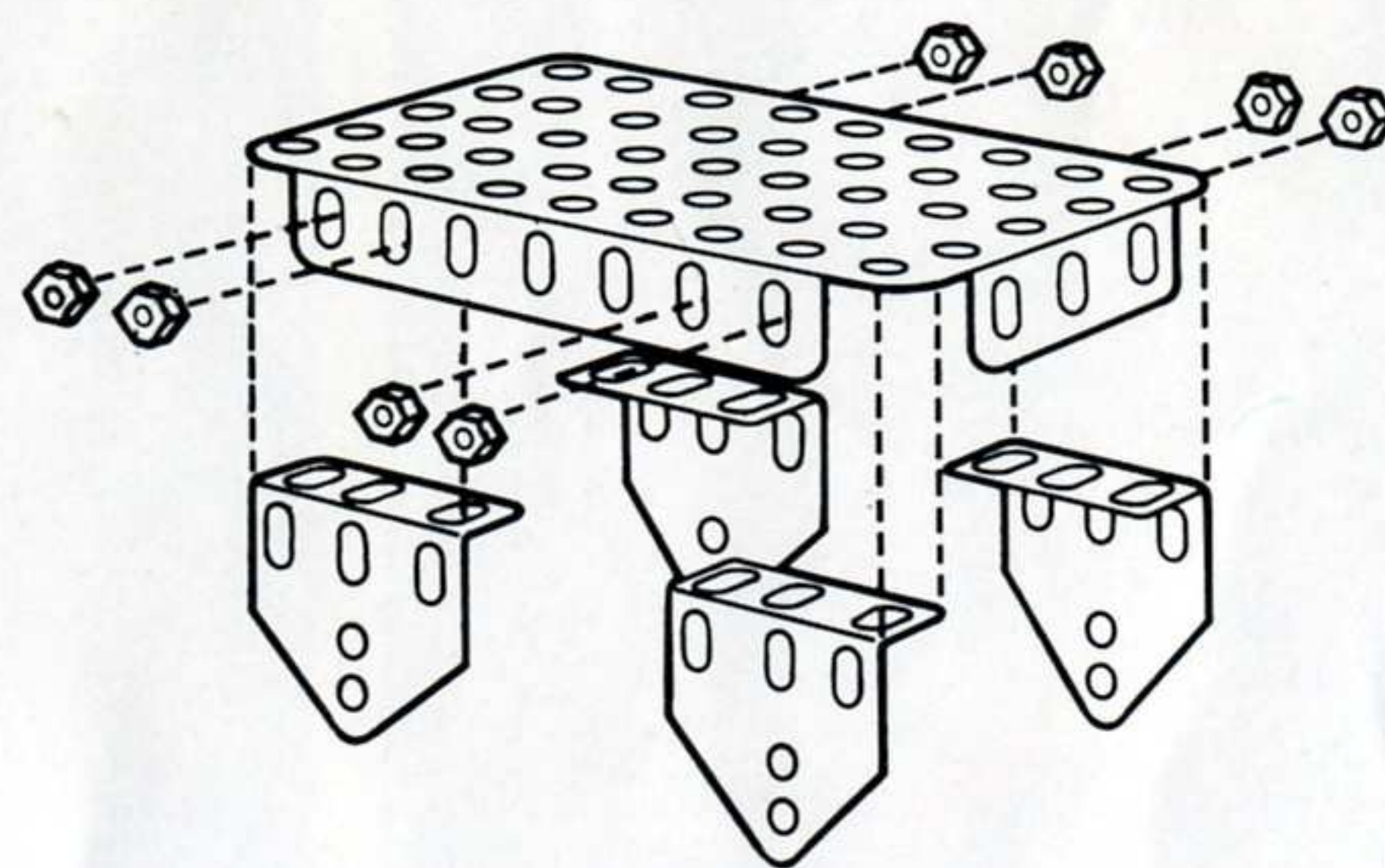

14

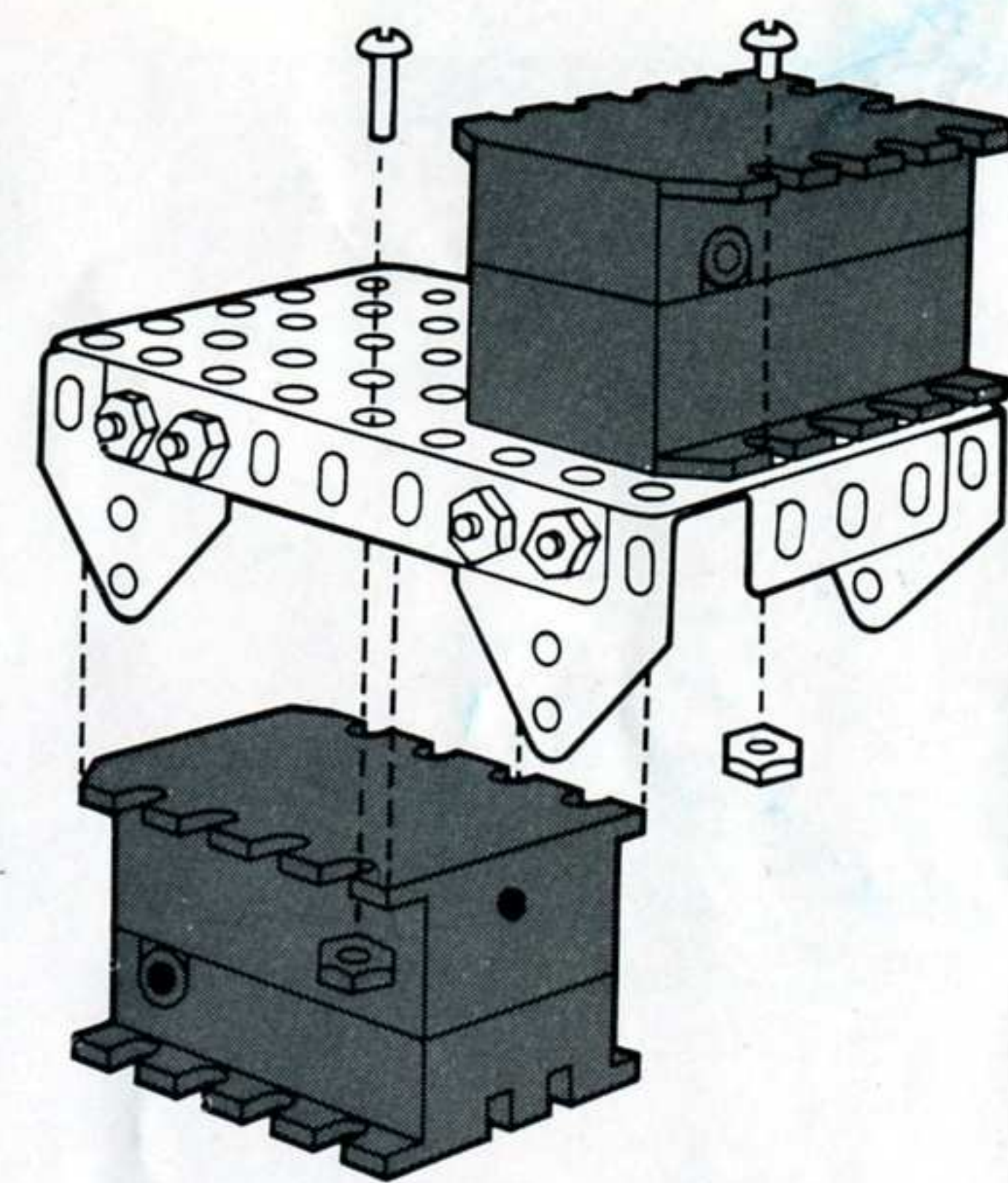

12

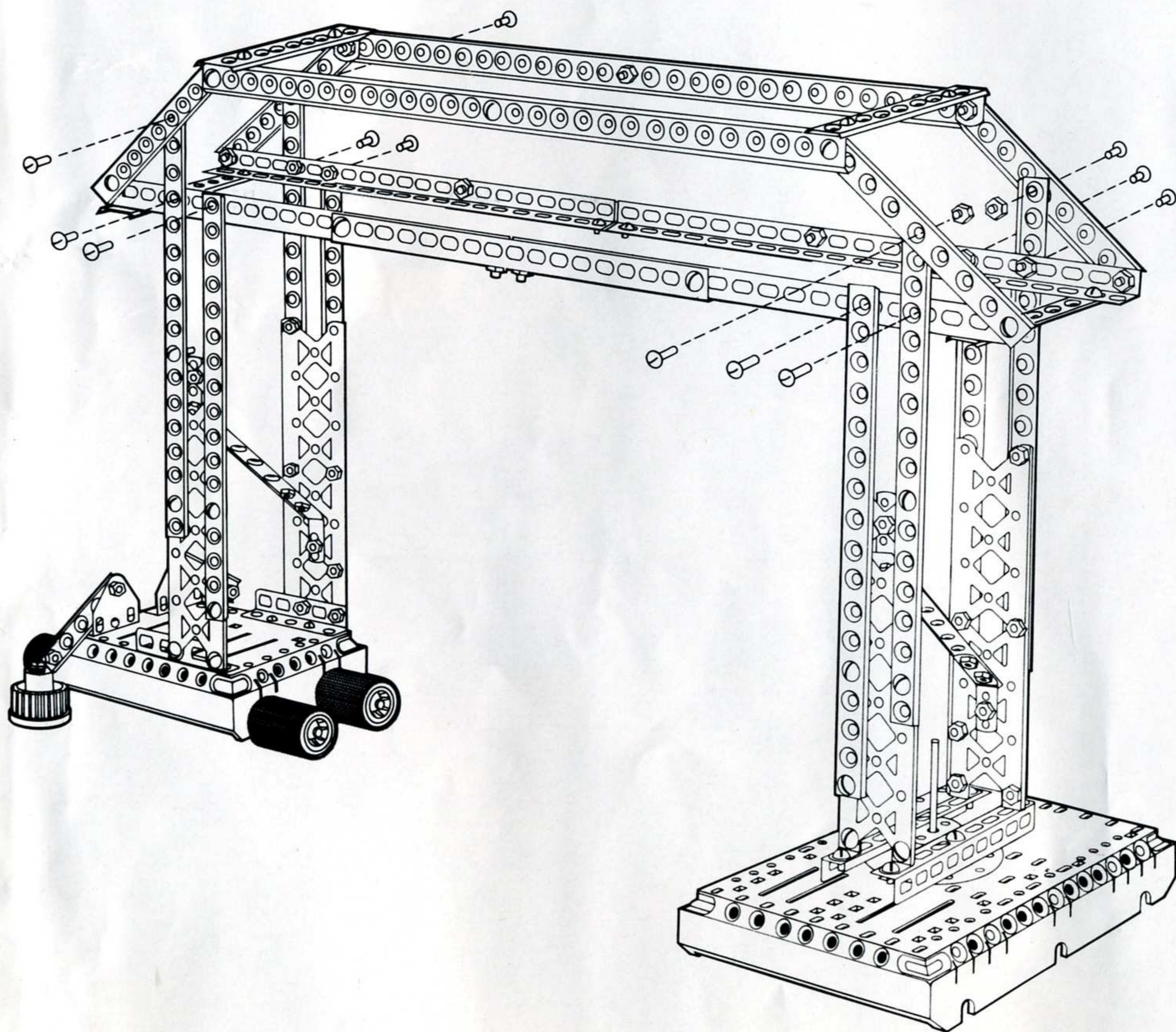

15

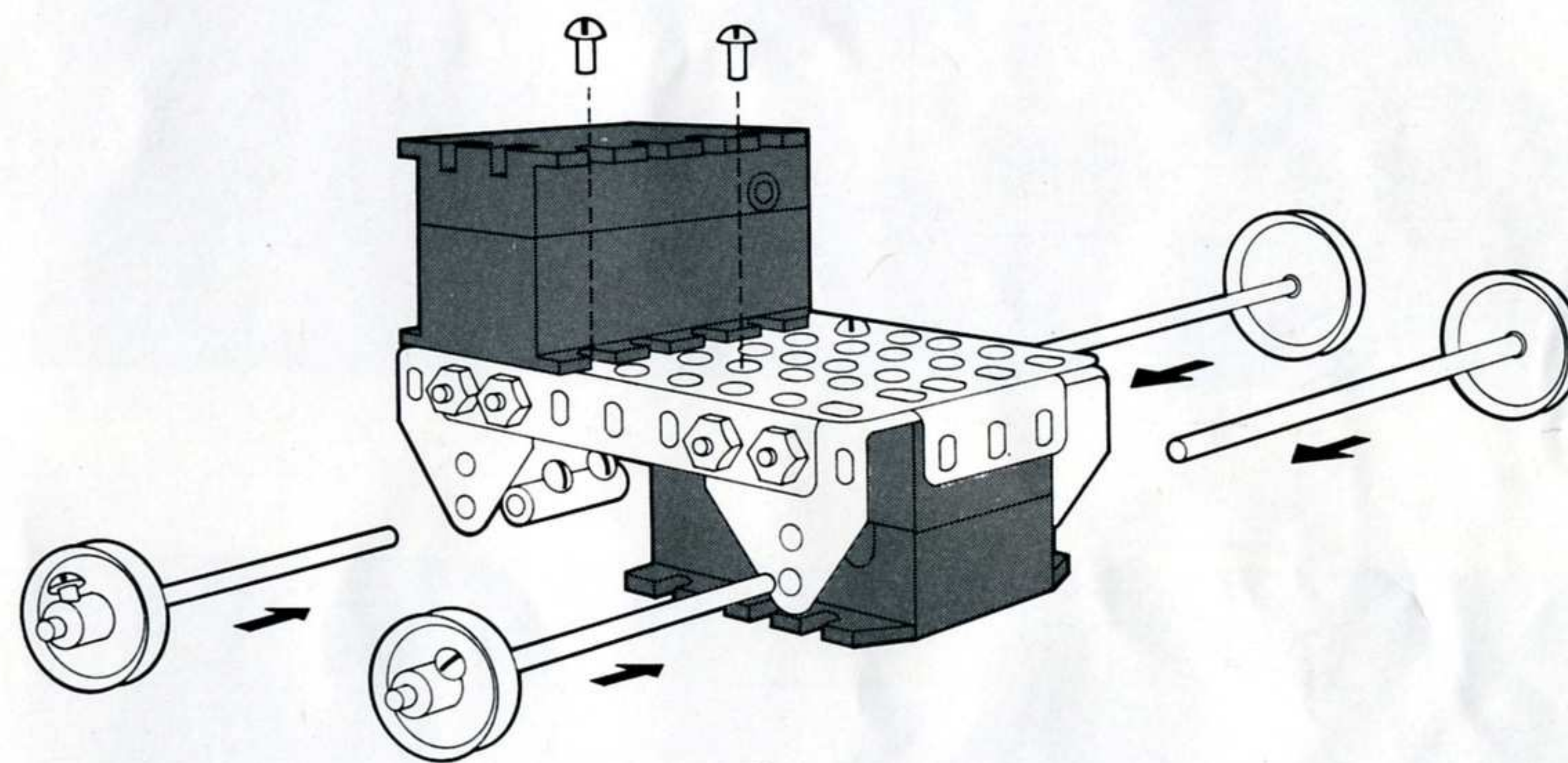

16

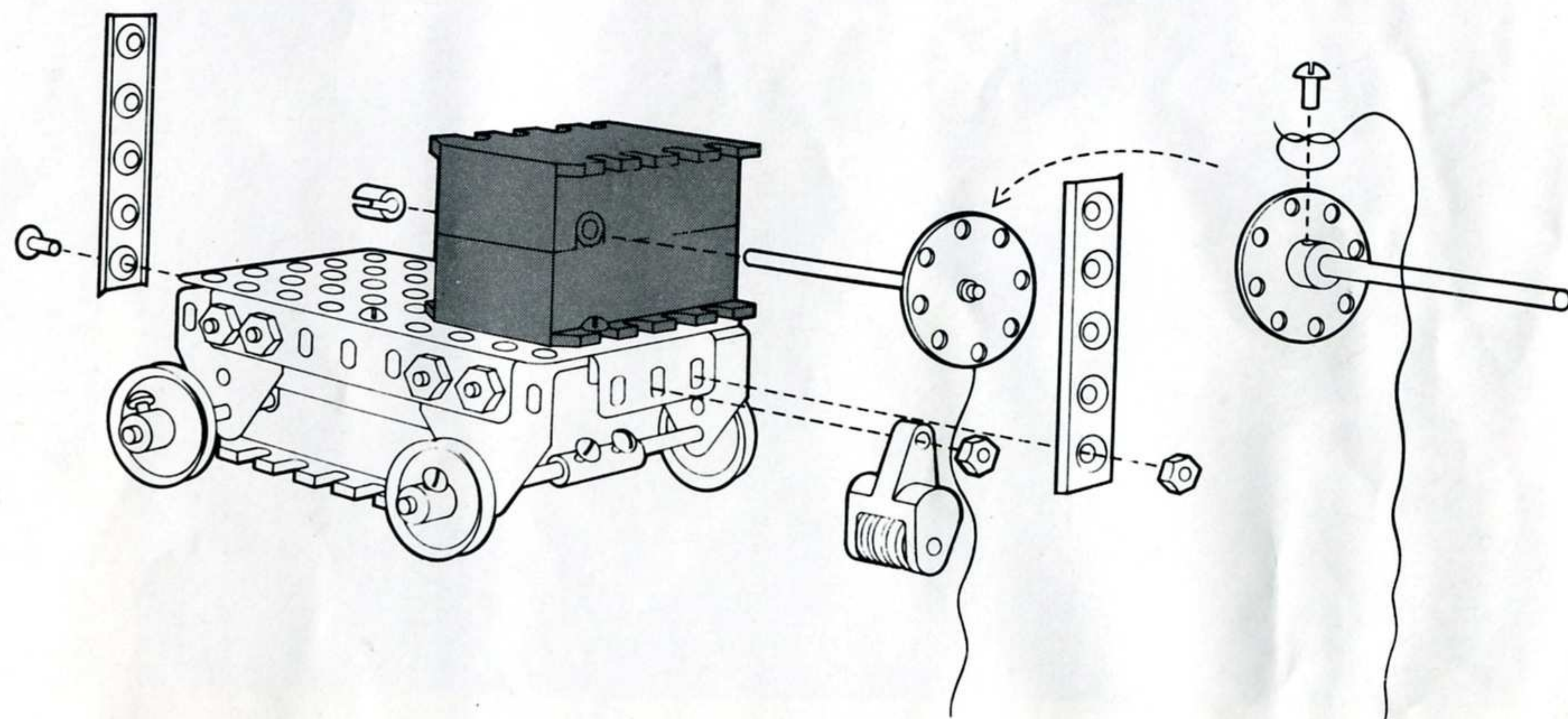



17

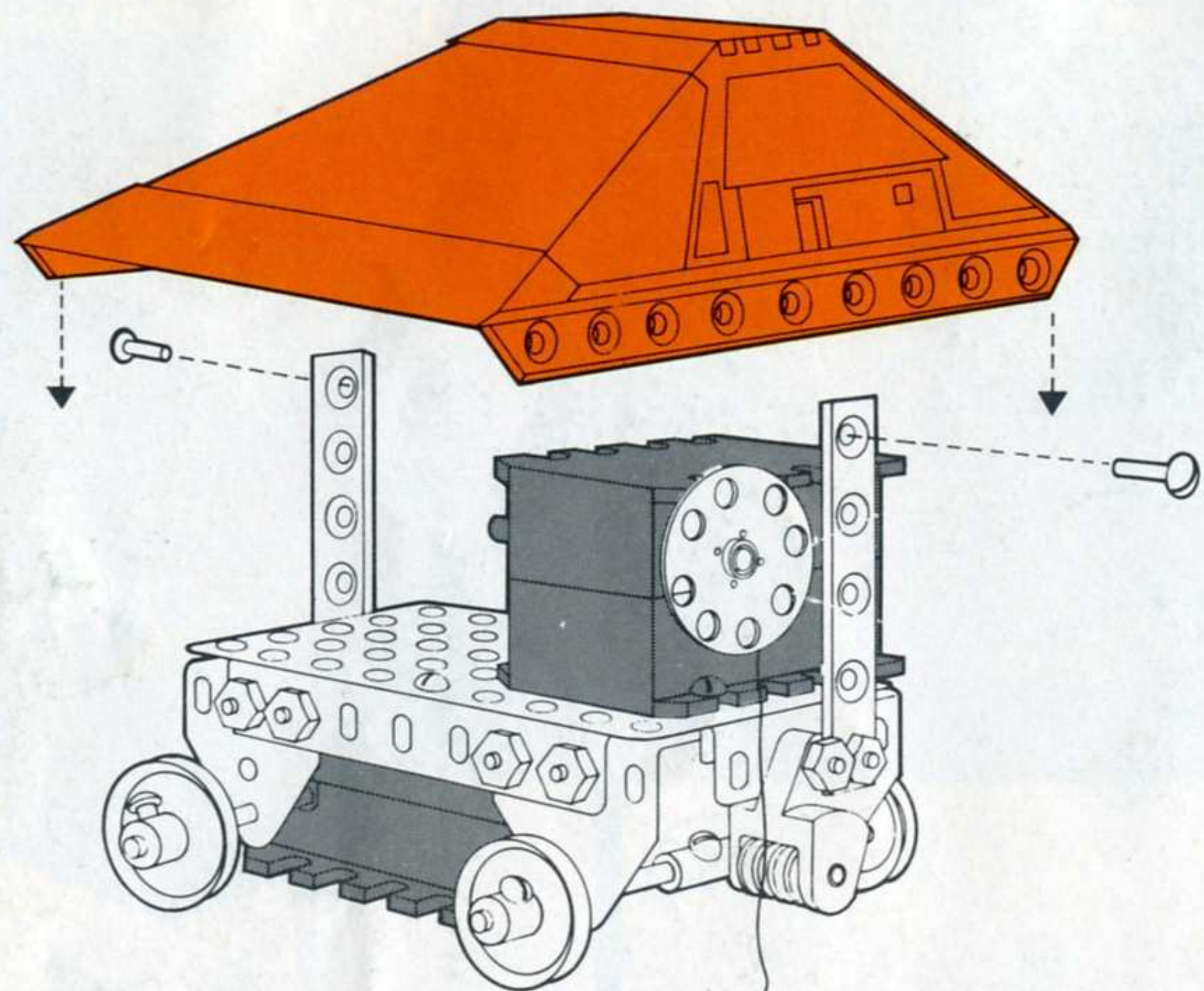

20

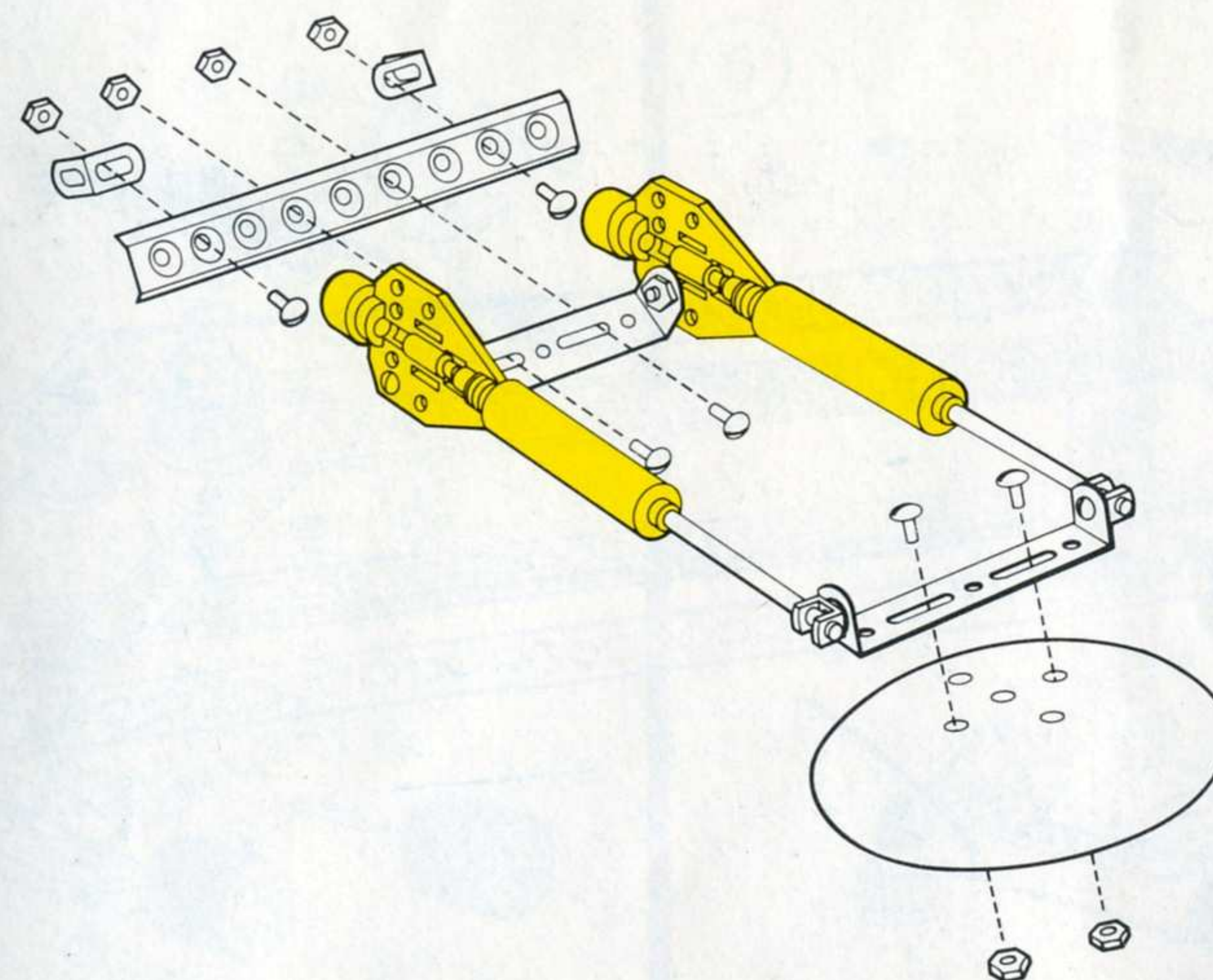

18

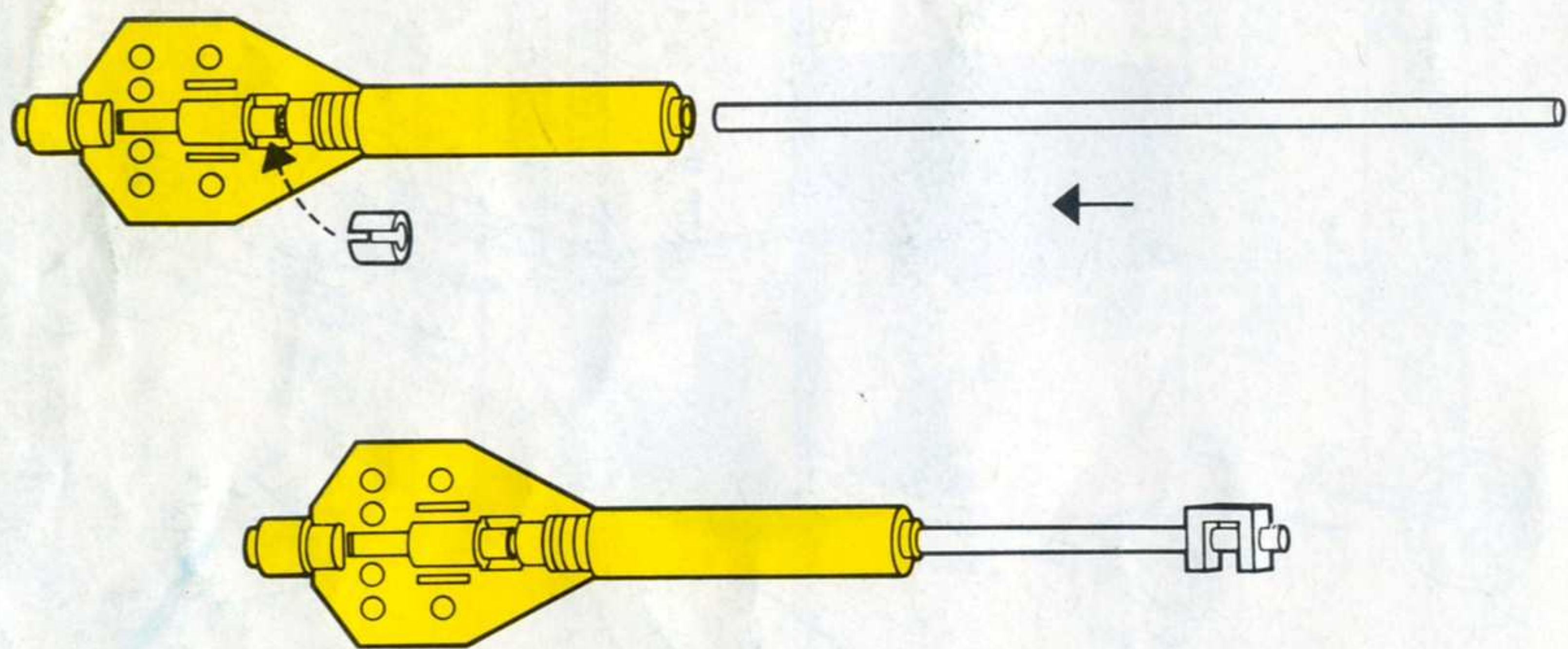

21

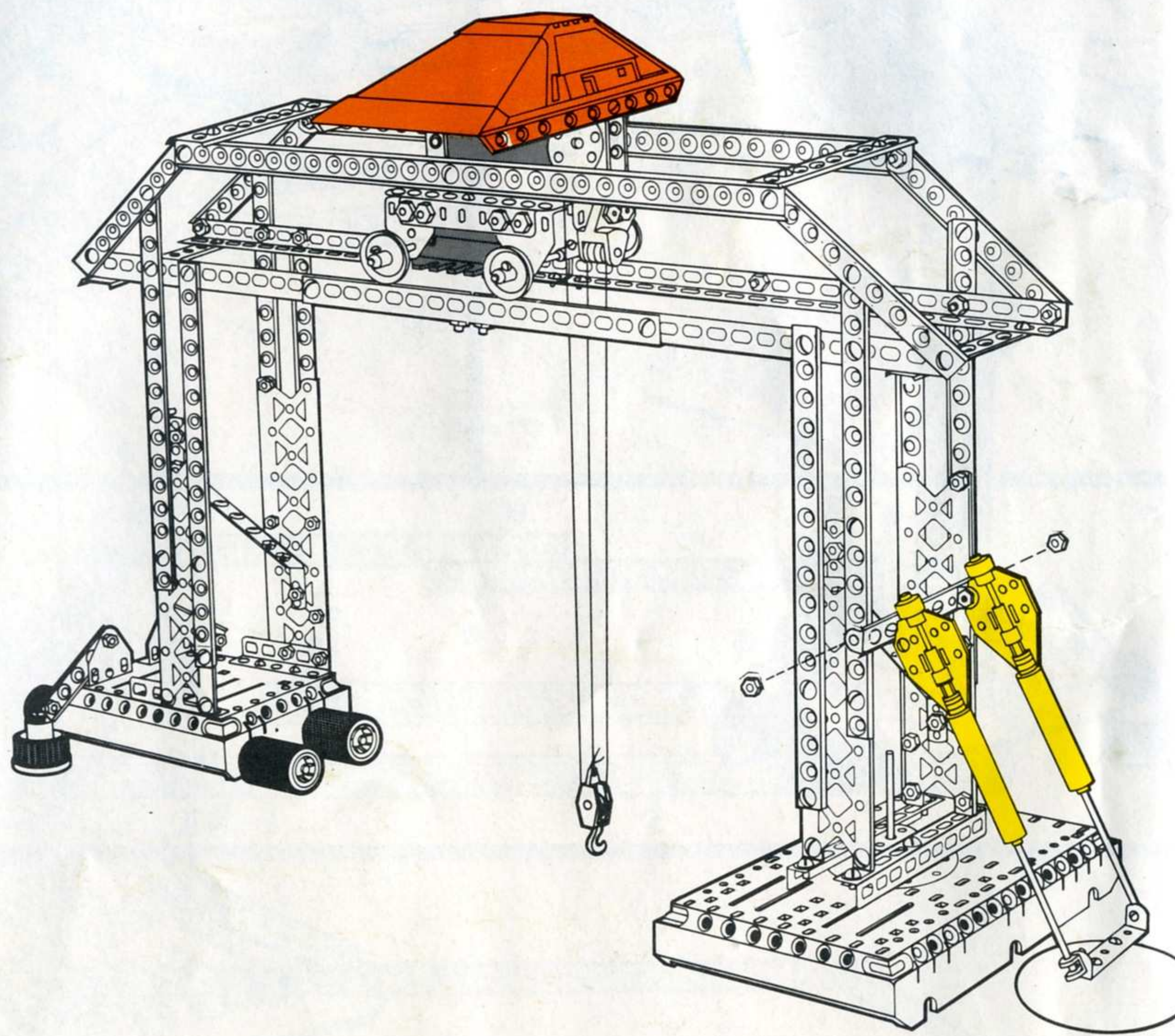
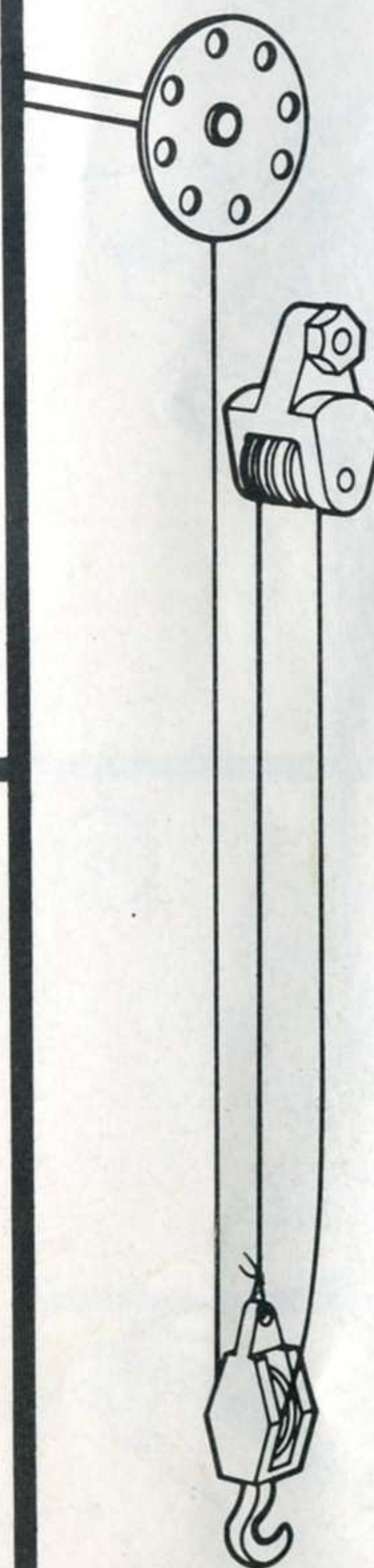

19

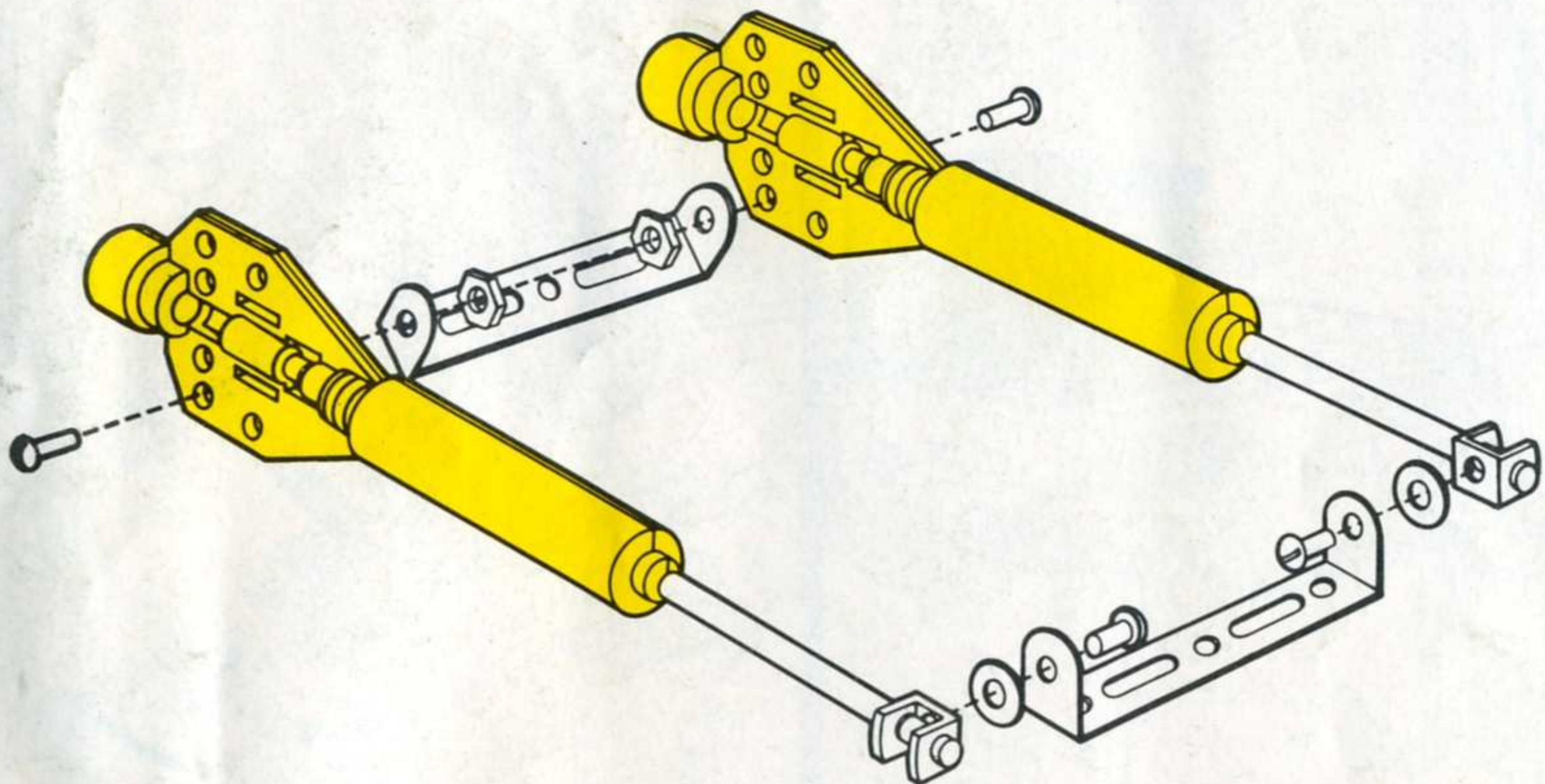



# ERECTOR<sup>®</sup>

The excitement of ERECTOR continues...

Buy any other of the four Erector Construction Systems so you can make even more big action models. You'll add major components to your set: motors, remote control units, chassis, wheels, cabs—as well as steel girders, nuts, bolts, and tools.

Imagine building an entire Space Command Post with Laser Cannons, Interplanetary Shuttles, and Moon Surface Vehicles—all at once! With Erector you can do it because the possibilities are endless!





**Gabriel<sup>®</sup>**

© MCMLXXXI Gabriel Industries, a division of CBS Inc.  
Hagerstown, MD 21740 M8763